

# 10

## Polymerisation

### 10.1 The structure and properties of polymers

They are all around us—as fibres in our clothing, the chairs we sit on, hard-wearing floor coverings, car parts and a myriad of other uses. What are they? Polymers.

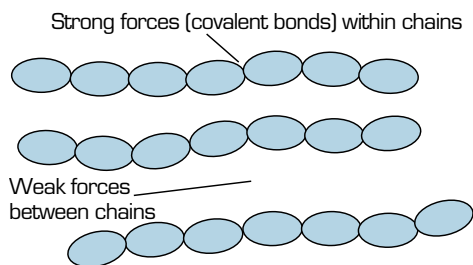
What exactly is a polymer? It is a large molecule made of many small units. Each small unit or molecule is called a monomer and they are joined together to make a polymer. By selecting particular monomers, and controlling the length of the polymer chain, scientists are able to create materials with a wide range of properties. They can be rigid or flexible, elastic or non-elastic, and able to be made into sheets and fibres and moulded into solid shapes. Most polymers are carbon based as carbon is able to form up to four covalent bonds and can make long molecular chains.

#### Thermoplastics and thermosetting polymers

One important property is whether the polymer is **thermoplastic** or **thermosetting**. A thermoplastic polymer softens when heated and can be moulded into a new shape. Most polymers are thermoplastics, or plastics for short. In thermoplastics, the polymer molecules exist as long chains with no cross-links or bonds between the chains (see figure 10.1). Heat energy overcomes the intermolecular forces, allowing the material to be reshaped and cooled.

A **polymer** is a large molecule made of many small units, called monomers.

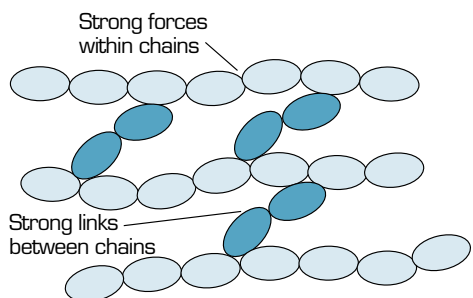
Some silicon polymers have been made.



**figure 10.1** Weak forces between the polymer chains of a thermoplastic polymer are easily broken by heating. The polymer can be moulded into a new shape.

Polyethene is a thermoplastic polymer used to make many everyday plastic items, such as containers and pipes for water.

A thermosetting polymer has covalent bonds or **cross-links** between the long polymer molecules. This makes a rigid, three-dimensional structure (see figure 10.2). Heat does not break the covalent bonds, so the structure cannot soften to be moulded. When heated, it remains hard and rigid until it chars.



**figure 10.2** Strong covalent bonds between the polymer chains of a thermosetting polymer cannot be easily broken. The polymer keeps its shape on heating.

An example of this kind of polymer is Bakelite, the first fully synthetic polymer made. It was used to make electrical fittings such as plugs and switches.

In the experiment below, a silicon-based polymer is reacted with ethanol. Ethanol bridges or connects the chains, as shown in figure 10.2, forming a new polymer with different properties: a rubbery, elastic solid.

## Experiment 10.1

### Making a cross-linked polymer super ball

#### materials

- 40% sodium silicate solution
- ethanol
- food colouring (optional)
- stirring rod
- 20 mL graduated measuring cylinder
- 400 mL beaker
- 10 mL graduated cylinder
- paper towels
- latex gloves

#### Purpose

To make a cross-linked polymer and observe its properties.

#### Method

- 1 Measure 20 mL of sodium silicate solution, and pour it into the 400 mL beaker. The solution can be coloured with a small amount of food colouring if desired.
- 2 Measure 5 mL of ethanol into the 10 mL graduated cylinder.
- 3 Add the ethanol to the sodium silicate solution.
- 4 Stir the mixture quickly as the solid begins to form.



- When the mixture is solid, remove from the beaker using latex gloves. If the mixture still has not formed a solid, add up to 5 mL more of ethanol.
- Mould the mixture into a ball as you hold it under running water. Use paper towels to dry it as you work. Do this gently, so the solid will not crumble. If it crumbles later, it can be reformed under running water.

### Results

Record your observations of the changes during the reaction. Observe and record the properties of the super ball.

### Discussion

The silicate polymer used at the start of the reaction was in the form of an aqueous solution. The polymer present at the end was an insoluble solid. Explain this difference in terms of the different structures of the two polymers.

#### safety

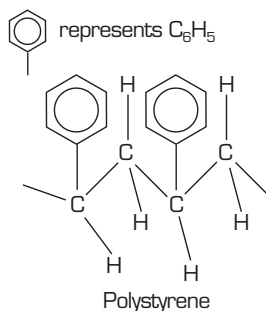
- Wear gloves, safety glasses and a laboratory coat for this experiment.
- Any excess material should be disposed of in the garbage.

## Other properties of polymers

Other physical properties of polymers depend on the length of the polymer molecules, whether there are any polar side groups and the presence and type of side chains.

As a general rule, longer polymer molecules are usually stronger. If there are no polar side groups, there will be only weak dispersion forces between the molecules. Polyethene, used for plastic bags, only has dispersion forces. However, the presence of an element such as chlorine means there will be polar bonds. Dipole–dipole forces will act between neighbouring molecules and the polymer will be stronger. Polyvinyl chloride, more commonly known as PVC or vinyl, is an example of a tough polymer that contains chlorine. Vinyl can be used instead of leather for hardwearing clothing and shoes.

If there are bulky side chains, polymer molecules cannot pack closely together and the polymer will be weaker. Polystyrene, used for foam drinking cups, yoghurt tubs and model kits, has bulky side chains, as shown in figure 10.3.



**figure 10.3** A section of the polystyrene molecule, showing the bulky side chains.

## Natural polymers

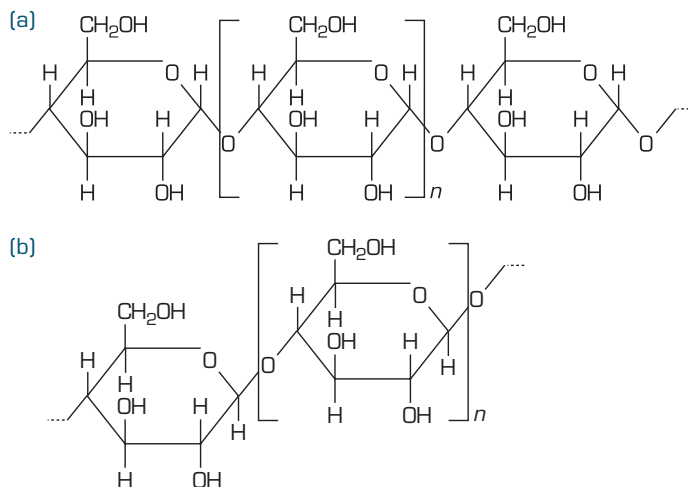
Polymers can be made artificially but they are also found in nature. In fact the first partly synthetic polymer, celluloid, was made from the natural polymer, cellulose. It was used to make dolls, film for photography and movies, and other everyday items.



Many items made of celluloid degrade after a time. This is a real problem for archives of historic films.



Plants make simple sugars such as glucose,  $C_6H_{12}O_6$ , a ring-shaped molecule. This is known as a **monosaccharide**. Glucose and other monosaccharides are also the monomer units for polymers. When you join two monosaccharides together, you get a disaccharide. Sucrose is a disaccharide made up of a glucose and a fructose. If you join a large number of monosaccharides together, you get the natural polymers **starch** and **cellulose**, shown in figure 10.4. These are called polysaccharides.



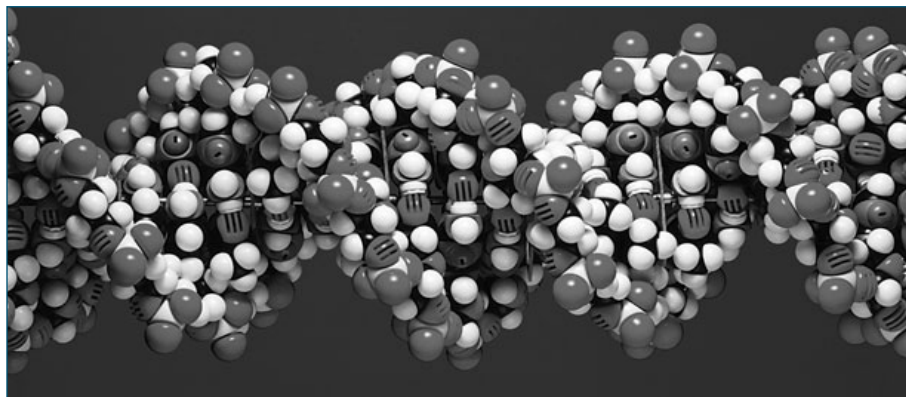
**figure 10.4** (a) A section of a starch molecule; (b) a section of a cellulose molecule. These molecules may contain several hundred to several thousand glucose monomers. The  $n$  in the formula represents the number of monomer molecules bonded together.

Starches are also known as complex carbohydrates. They are an important source of energy in our diet. Humans cannot digest cellulose (fibre) because of the way the monomer units are bonded together. Cellulose is the main component in wood and in fibres such as cotton and wool.

**Proteins** and **DNA** are also polymers; they are very long molecules made of smaller units joined together. In this case, however, the smaller units are not all identical. It is the order of the monomer units that give proteins and DNA particular properties.



**figure 10.5** Spider silk is an immensely strong protein-based polymer.



**figure 10.6** DNA is a very long, naturally occurring molecule.

One protein-based polymer that is unique is spider silk. Spiders spin it for items such as webs, linings of tunnels and egg cases. Some sections of the protein are very ordered, making the silk the strongest known substance for its thickness. Other sections are helical or spiral molecules, giving it great elasticity.

It has been said that if spider silk was the diameter of a pencil, a web could stop a passenger jet.

In the experiment below, a polymer similar to starch is used to make slime. Guar gum is a starch polymer made of glucose monomers. Sodium tetraborate forms cross-links between some of the polymer chains, altering the properties of the polymer.

## Experiment 10.2

### Ghostbuster slime—modifying a natural polymer to make slime

#### Purpose

To modify a natural polymer, creating a new polymer with different properties.

#### Procedure

- 1 Pour 100 mL of distilled water into a beaker and add a few drops of food colouring.
- 2 Sprinkle in some of the guar gum and stir until it is dissolved. In this way, gradually add up to 0.7 g of guar gum to the water and continue stirring until it thickens.
- 3 Now add 5 mL of sodium tetraborate solution and stir. The mixture should gel within a minute. The slime should be stored in an airtight container (like a zip-lock bag) to keep it from drying out.

#### Results

Describe the appearance and properties of the reactants and product.

#### Discussion

- 1 Explain why the new polymer has properties which are different to those of the original guar gum.
- 2 Where do you think the water that was present has gone?

#### materials

- 0.7 g guar gum
- 4% sodium tetraborate solution (4 g sodium tetraborate, 100 mL distilled water)
- stirring rods
- 100 mL distilled water
- 10 mL graduated cylinder
- food colouring
- 400 mL beaker

#### safety

- Wear safety glasses and a laboratory coat for this experiment.
- Rinse the beaker after use.
- Dispose of waste in garbage.

#### Questions

- 1 Explain the difference between thermoplastic and thermosetting polymers.
- 2 A kitchen container was left resting against a hot sandwich toaster. Now the container has a hole in it surrounded by a blob. Explain this change in terms of the type of polymer it is made from.
- 3 Several factors affect the properties of polymers. Use a table to summarise these factors and the effect each has on the properties of a polymer.
- 4 What would be the approximate molar mass of a starch molecule containing 3000 glucose units? A glucose molecule has the formula  $C_6H_{12}O_6$ . A water molecule,  $H_2O$  is lost from each glucose unit as the starch molecule forms, so each glucose monomer unit in the starch has the formula  $C_6H_{10}O_5$ .

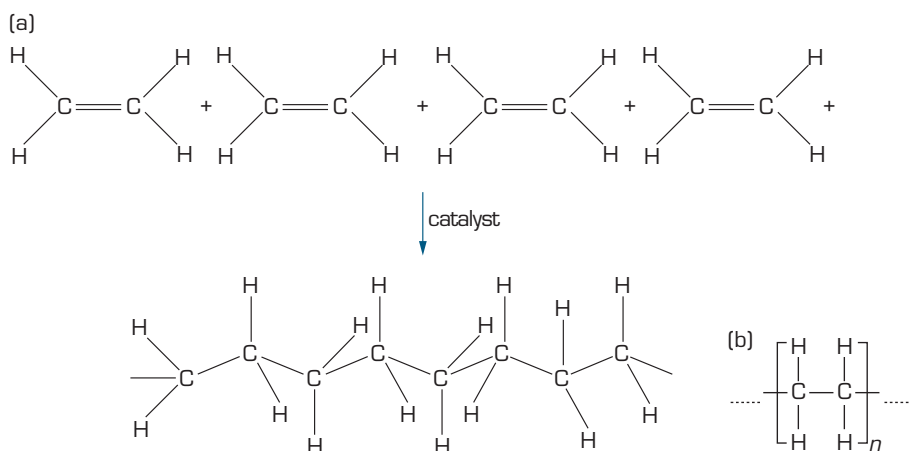
## 10.2 Addition polymerisation

Occasionally monomers contain triple bonds. Polymers made from such monomers may have unusual properties, such as electrical conductivity.

Ethene was called ethylene in the past, so polyethene is sometimes called polyethylene.

As we saw above, polymers can be classified by their properties. They can also be classified by how they are made. The first group we will consider are the **addition polymers**, formed when monomers are added together to make the long polymer molecules. For this to happen, the monomers usually contain double bonds; they are alkenes.

To create an addition polymer, the alkene is compressed and heat or a catalyst is added. The double bonds break and reform as single bonds plus a bond joining it to another monomer unit. The chain continues to grow in this fashion. When the polymer is long enough, an alkane is added to stop the reaction. Polymers may contain hundreds or even thousands of monomer units. The simplest addition polymer is polyethene, made from the ethene monomer (figure 10.7).



**figure 10.7** (a) The formation of polyethene by the addition of ethene monomers. (b) The general formula of polyethene.

Low-density polyethene, or LDPE, is made using high temperature and high pressure to combine the monomers. Many of the chains are irregular and branched. High-density polyethene, or HDPE, is made using a catalyst at high pressure. This eliminates the branching. The polymer molecules pack more closely. LDPE is suitable for plastic bags, while HDPE is used for pipes, bottles and toys.

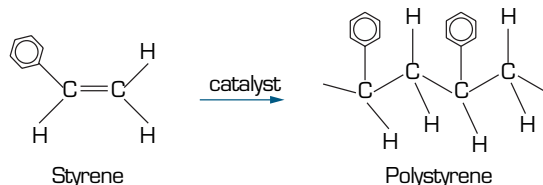
### Other addition polymers

Other common addition polymers are **polyvinyl chloride (PVC)**, **polystyrene**, **polypropene**, **polyacrylonitrile**, **acrylic** and **Teflon**. The uses of each polymer depend on its properties.

PVC, often called vinyl, is a tough, hardwearing polymer used for jackets, shoes and furniture coverings. It was also used for making music recordings—your parents may even have some old vinyl records.

Polystyrene molecules are loosely packed because of the bulky benzene rings attached to the polymer chain (see figure 10.3). Polystyrene can be used to make tough containers such as yoghurt tubs and babies' bottles. It has even more uses

because of a unique property. This polymer can be expanded in size into a lightweight material. It is first produced as tiny beads, which expand when they are steamed. The beads can be heated into block form, which has many uses. As there is trapped air in the expanded form, polystyrene foam is an excellent heat insulator and is used in refrigerators, cold rooms, and vegetable cartons. It is also used to provide cushioning in bicycle helmets, packaging and as the beans in beanbags. More unusual uses include pontoon making and as a void former in concrete and bridge-making.



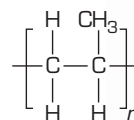
**figure 10.8** Styrene monomers undergo polymerisation to form polystyrene.

Polypropene is made from propene. The general formula of polypropene is shown in figure 10.10. Polypropene melts at 121°C and is less dense than water. It is resistant to moisture and solvents. As a result, it can be used for making items that need to be sterilised, such as disposable medical supplies. It can be spun into fabric, and is strong enough to make packaging, luggage and ropes that float.

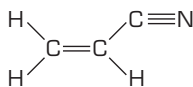
Monomers such as acrylonitrile and methyl methacrylate are used to make a group of polymers known as acrylics. They are resistant to bleaches, dilute acids and alkalis, weathering and attack from microbes. They are used for bulky fabrics and paints. A section of the polymer chain of polymethyl methacrylate (acrylic) is shown in figure 10.12.



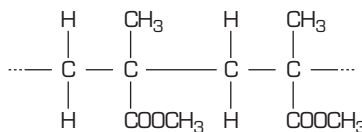
**figure 10.9** This esky is made of polystyrene.



**figure 10.10**  
The general formula of polypropene.



**figure 10.11** The monomer acrylonitrile is used to make the acrylic, polyacrylonitrile.



**figure 10.12** A section of the chain of polymethyl methacrylate.

Teflon is made from a monomer that is similar to ethene, except all four hydrogen atoms are replaced by fluorine. This polymer is unreactive and heat resistant. It has a low attraction to other substances such as oil and water. This makes it ideal for non-stick coatings on cookware. It is also used in low-friction lubricants and bearings, and to treat fabrics to make them stain resistant.

To create even greater variation in the properties of polymers, scientists have explored **copolymers**. Copolymers are made from two or more different monomers. By using two monomers with different structures and properties, the resulting polymer will have new and useful properties.

## Questions

- Which would be stronger, LDPE or HDPE? Explain.
- For the monomer shown in figure 10.11, draw a section of the polymer chain, and also the general formula.
- Use the general formula shown in figure 10.12 to draw the structure of the methyl methacrylate molecule.
- Which polymer molecule would pack more closely, polypropene or polystyrene? Explain.
- Draw a possible section of a copolymer molecule made from ethene and propene.

## 10.3 Condensation polymerisation

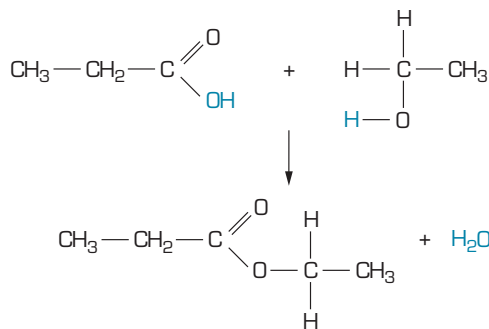
The second group of polymers is known as **condensation polymers**. Condensation polymers are formed when monomer molecules react and combine, in the process releasing a small molecule such as water. This type of reaction is known as a condensation reaction.

An example of a condensation reaction is the formation of an **ester**. Esters are compounds commonly found in nature and often have distinctive fragrances. An ester bond is formed when a carboxylic acid reacts with an alcohol. It is named according to the particular acid and alcohol used. In order to name esters, the names of some alcohols and acids are shown in table 10.1.

**table 10.1** The names and formulae of some alcohols and carboxylic acids.

Name of alcohol	Formula of alcohol	Name of carboxylic acid	Formula of acid
methanol	CH <sub>3</sub> OH	methanoic acid	HCOOH
ethanol	CH <sub>3</sub> CH <sub>2</sub> OH	ethanoic acid	CH <sub>3</sub> COOH
1-propanol	CH <sub>3</sub> CH <sub>2</sub> CH <sub>2</sub> OH	propanoic acid	CH <sub>3</sub> CH <sub>2</sub> COOH
1-butanol	CH <sub>3</sub> (CH <sub>2</sub> ) <sub>2</sub> CH <sub>2</sub> OH	butanoic acid	CH <sub>3</sub> (CH <sub>2</sub> ) <sub>2</sub> COOH
1-pentanol	CH <sub>3</sub> (CH <sub>2</sub> ) <sub>3</sub> CH <sub>2</sub> OH	pentanoic acid	CH <sub>3</sub> (CH <sub>2</sub> ) <sub>3</sub> COOH
1-hexanol	CH <sub>3</sub> (CH <sub>2</sub> ) <sub>4</sub> CH <sub>2</sub> OH	hexanoic acid	CH <sub>3</sub> (CH <sub>2</sub> ) <sub>4</sub> COOH
1-heptanol	CH <sub>3</sub> (CH <sub>2</sub> ) <sub>5</sub> CH <sub>2</sub> OH	heptanoic acid	CH <sub>3</sub> (CH <sub>2</sub> ) <sub>5</sub> COOH
1-octanol	CH <sub>3</sub> (CH <sub>2</sub> ) <sub>6</sub> CH <sub>2</sub> OH	octanoic acid	CH <sub>3</sub> (CH <sub>2</sub> ) <sub>6</sub> COOH
1-nonanol	CH <sub>3</sub> (CH <sub>2</sub> ) <sub>7</sub> CH <sub>2</sub> OH	nonanoic acid	CH <sub>3</sub> (CH <sub>2</sub> ) <sub>7</sub> COOH
1-decanol	CH <sub>3</sub> (CH <sub>2</sub> ) <sub>8</sub> CH <sub>2</sub> OH	decanoic acid	CH <sub>3</sub> (CH <sub>2</sub> ) <sub>8</sub> COOH

Figure 10.13 shows the condensation reaction between propanoic acid and ethanol.



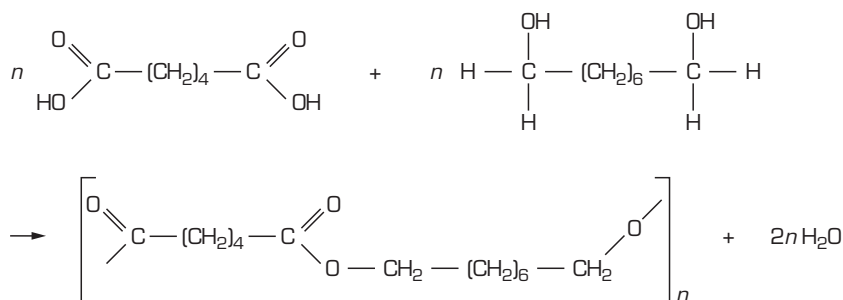
**figure 10.13** Propanoic acid and ethanol react to form an ester named ethyl propanoate. A water molecule is also formed.



In this reaction, a hydrogen atom from the OH group in the alcohol combines with the OH group of the carboxylic acid. These atoms are shown in contrasting colour (figure 10.13). The propanoic acid and ethanol are bonded together by one of the remaining oxygen atoms. This ester is named ethyl propanoate. The first part of the name is derived from the name of the alcohol by removing the ending and adding -yl. The second part of the name is derived from the name of the acid. The ending of the acid's name is removed and the ending -oate is added.

If an ester is made from octanol and ethanoic acid, it would be named octyl ethanoate.

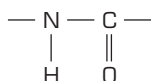
Polyesters are an important example of condensation polymers. In order to make a polyester, each monomer must have two functional groups. In this way, the monomers can join end-to-end. Usually two different monomers are used: one has carboxylic acid functional groups at both ends and the other has alcohol functional groups at both ends. Each monomer can form two bonds. Figure 10.14 shows the formation of a **polyester**.



**figure 10.14** Monomers with acid and alcohol groups react to form polyester.

Copolymers such as this are known as A-B polymers. A represents one monomer and B the other. The polymer chain can be symbolised as A-B-A-B-A-B-. Polyester can be made into fine fibres and woven into cloth. It is often combined with cotton, to produce a crease-resistant fabric.

Nylon is a type of condensation polymer known as a **polyamide**. The monomers combine forming an amide bond (see figure 10.15). An amide bond consists of a nitrogen atom bonded to a carbon atom which is joined by a double bond to an oxygen atom.

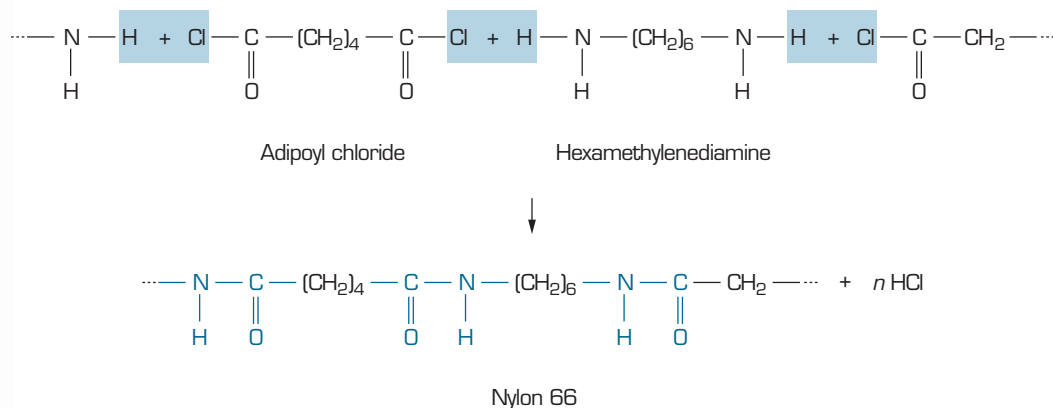


**figure 10.15** An amide bond. It can be thought of as having a carboxylic acid section, containing the oxygen atom, and an amine section, containing the nitrogen atom.

The nitrogen is supplied by an amine. An amine is a carbon compound with an -NH<sub>2</sub> group attached to a carbon atom. Carboxylic acids contain a carbon double bonded to an oxygen atom. However, an amide cannot be made directly from a carboxylic acid and an amine. Instead, derivatives of acids must be used. The reaction in figure 10.16 shows how nylon 66 is formed. Adipoyl chloride and hexamethylenediamine react, eliminating a HCl molecule for every amide bond that is formed. The adipoyl chloride has been made from a carboxylic acid. The 66 in the name refers to the fact that each monomer molecule has 6 carbon atoms.

Amide bonds also exist in the natural polymers called proteins.





**figure 10.16** A HCl molecule is released for every bond that forms as the nylon polymer is made. The H and Cl atoms are shaded. The amide bonds are shown in blue.

Nylon can be extruded to form very fine, strong fibres. It is hardwearing, non-toxic, non-flammable and chemical-resistant. It is used for stockings, carpets, clothing, ropes, paint brushes, electrical parts and parachutes.

## Worksheet 1

Polymers

# Experiment 10.3

## The nylon rope

### materials

- 25 mL 5% (m/v) 1,6-diaminohexane in water with 5% Na<sub>2</sub>CO<sub>3</sub>
- 25 mL 5% (v/v) adipoyl chloride in hexane
- 100 mL beaker
- wire hook
- stirring rod

### safety

- Wear gloves, safety glasses and a laboratory coat for this experiment.
- Dispose of solid waste in the garbage.
- Liquid waste containing hexane should be placed in a waste beaker and returned for safe disposal.
- Flames should not be used in the area where this experiment is being conducted.
- The experiment should be carried out in a fume cupboard or a well-ventilated area.

In the following experiment, you will make nylon 66. The monomers are dissolved in different solvents that do not mix. A rope of nylon can be drawn from the interface of the two solutions.

### Purpose

To make a condensation polymer and observe some of its properties.

### Method

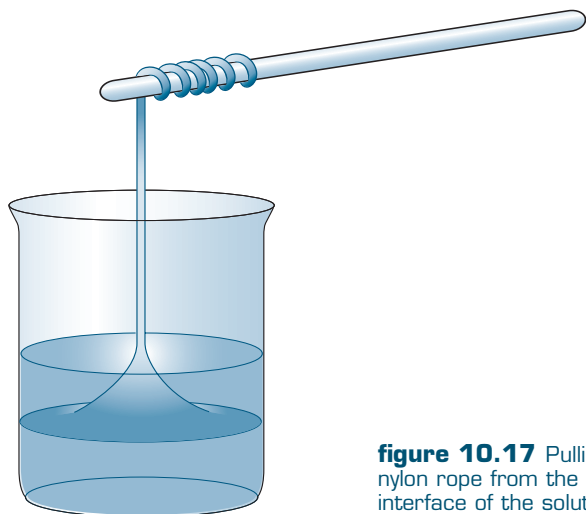
- 1 Pour 25 mL of aqueous 1,6-diaminohexane solution into a 100 mL beaker.
- 2 Tilt the beaker. Slowly pour 25 mL of adipoyl chloride in hexane down the side of the beaker, to form a separate layer above the water layer.
- 3 Gently dip the wire hook into the beaker. From the interface, pull out a string of nylon. This can be wound around the stirring rod, as shown in figure 10.17.
- 4 When you have finished pulling the string, you may mix the two solutions together, so the reaction is completed.
- 5 Wash the products several times in water and dry with paper towel.

### Results

Gently unwind a section of nylon rope. Observe properties such as strength and elasticity of both the rope, and the product obtained in step 4. Record these and any other observations you have made.

10





**figure 10.17** Pulling nylon rope from the interface of the solutions.

### Discussion

- 1 As the nylon is being wound around the stirring rod, suggest how the polymer molecules may be aligned. Does this alignment lead to high strength?
- 2 In what ways do the nylon rope and the product made in step 4 differ? Try to explain why.

### Questions

- 10 Complete the following word equations.
  - a methanol + pentanoic acid  $\rightarrow$
  - b ethanol + ethanoic acid  $\rightarrow$
  - c butanol + propanoic acid  $\rightarrow$
- 11 What small molecule is released in the formation of a polyester?
- 12 Explain the difference between addition and condensation polymers.
- 13 Why is it necessary for the monomers of condensation polymers to contain a functional group at each end? Suggest what would happen as the polymer formed if molecules with only one acid or one alcohol group were added to the mixture.

## 10.4 Resources

### Raw materials

Polymers, as we have seen, are made of small monomers usually containing carbon. The raw material for the monomers is obtained from oil.

Oil contains a number of different hydrocarbons of varying length. Most of them are too long for making polymers (and also for petrol) so they undergo a process called **cracking**. The molecules are heated and broken into smaller pieces. During this process double bonds are formed. These smaller molecules can be used as the basis of addition polymers, or modified to make the starting products for condensation polymers.



Fossil fuels are based on oil, coal or natural gas. They were made deep underground from fossilised plants and animals.

The word recycle is often in error to describe something that is reused. The two terms do not mean the same thing.

As you know, oil is a fossil fuel. There are limited reserves of oil underground and the reserves will eventually run out. It has been said that it is such a valuable resource for the chemical industry that we should not waste it as fuel for transport. As oil resources are limited, we need to develop ways to use them wisely and conserve what we have.

## Reusing and recycling

It is more efficient to reuse polymers a number of times, rather than using new products. For example, plastic take-away food containers can be reused as freezer containers or lunch boxes. Shopping bags can be used for rubbish instead of buying special bags.

Recycling means processing the polymer, to eventually make a new item. The items to be recycled must first be cleaned and then sorted into different types. You may have noticed that many items are branded with a symbol, like those in figure 10.18. This indicates to recyclers what type of polymer the item is made of. It is important that only polymers of the same type are recycled together. This enables the recycled product to have known physical and chemical properties. If the recycled product contained a mixture of several polymers, it may no longer have consistent or even desirable properties.



**figure 10.18** These symbols indicate what type of polymer has been used in the item.

Any labels must be removed before recycling. The item may be remelted, ready for remoulding, or cut into fine flakes. Recycled plastic can only be used for certain applications. It is not used for anything that will come in contact with food or beverages. Sometimes the outer part of a drink container may be made of recycled plastic, with an inner shell of new material.

Recycling can be carried out on a large scale. In factories, waste material can be conveniently recycled at the site. Plastic sheets, used by farmers to control weeds over large areas, are collected and recycled.

## Questions

- 14 Look for the symbols found on recyclable polymers. Research the meaning of these symbols.
- 15 Think of three ways you can reuse items made of polymers, for a new purpose.
- 16 Explain the difference between the words reuse and recycle. Give examples of each.

## Summary ▶▶▶▶

- ▶ A **polymer** is a large molecule made of many smaller molecules, called **monomers**. Polymers have different properties which depend on the length of the polymer molecules, what other atoms are present, the degree of branching, and the presence or absence of cross-links between polymer chains.
- ▶ **Thermoplastic polymers** have no **cross-links** between the polymer molecules. The forces of attraction between polymer chains consist of intermolecular forces. The polymers soften when heated and can be moulded to form new shapes.
- ▶ **Thermosetting polymers** have cross-links between the polymer chains. The cross-links are held together by covalent bonds. Thermosetting polymers do not soften when heated, but remain rigid. On heating, they eventually char.
- ▶ Natural polymers include **starch**, **cellulose**, **protein** and **DNA**. Their functions depend on their specialised properties.
- ▶ An **addition polymer** is made from monomers with double bonds. The molecules add together to make the polymer. The double bonds become single bonds and new bonds form. **Polyethene** is the simplest addition polymer. It is made from ethene. Other common addition polymers are polyvinyl chloride (PVC), polystyrene, polypropene and Teflon.
- ▶ **Copolymers** are made from two or more different monomers. Their properties may be different from polymers made of a single monomer.
- ▶ A **condensation polymer** is made when water or another small molecule is eliminated to form each new bond as monomers combine. **Polyesters** and **polyamides** are the main types. Nylon is an example of a polyamide.
- ▶ Monomers are mostly manufactured from oil, which is a fossil fuel. Oil is first made into smaller fragments, with double bonds, by the process of **cracking**.
- ▶ Fossil fuels are a limited resource. It is important to use this resource and its products wisely. To conserve oil, it is important to **reuse** or **recycle** polymers.

## Key terms ▶▶

addition polymer

cellulose

condensation polymer

copolymers

cracking

cross-links

DNA

monomer

polyamide

polyester

polyethene

polymer

polypropene

polystyrene

polyvinyl chloride

protein

recycle

reuse

starch

Teflon

thermoplastic polymer

thermosetting polymer



## Chapter Review

### 10.1 The structure and properties of polymers

- 17 Explain the difference between a monomer and a polymer.
- 18 a Name one use for a thermosetting polymer found around the house and explain why it needs to be thermosetting.  
b Why are thermoplastic polymers more commonly used than thermosetting polymers?
- 19 Research the causes and chemistry of degradation of celluloid. Is it inevitable? Can it be slowed or halted?
- 20 Explain each of the following in terms of the structure of each type of polymer.  
a Thermosetting polymers are harder than thermoplastic polymers.  
b Thermoplastic polymers melt when heated but thermosetting polymers do not.  
c Thermoplastic polymers and thermosetting polymers are both poor conductors of electricity.

### 10.2 Addition polymerisation

- 21 Polyethene can be produced in a branched or unbranched form. Compared to the branched form, the unbranched form shows:  
A higher density and higher melting temperature.  
B higher density and lower melting temperature.  
C lower density and higher melting temperature.  
D lower density and lower melting temperature.
- 22 Polyethene and polystyrene are both thermoplastic hydrocarbon polymers. Polystyrene is tougher than polyethene because polystyrene has:  
A air bubbles between the chains.  
B cross-linking between the chains.  
C stronger hydrogen bonds between the chains.  
D stronger dispersion forces between the chains.

- 23 Plasticisers can be added to polymers to change their properties. Plasticisers are small molecules that hold polymer chains further apart. Polymers containing added plasticisers are likely to be:  
A softer with higher melting temperatures.  
B softer with lower melting temperatures.  
C harder with higher melting temperatures.  
D harder with lower melting temperatures.
- 24 Recent research has led to the production of some polymers that conduct electricity. One of these is a form of polyethyne, formed by addition polymerisation of ethyne ( $\text{HC}\equiv\text{CH}$ ). Polyethyne consists of alternating single and double covalent bonds between carbon atoms.  
a Draw a section of the polymer polyethyne.  
b Suggest how it may be able to conduct electricity.

### 10.3 Condensation polymerisation

- 25 Which of the following is most likely to act as a monomer? Explain.  
ethanoic acid, ethanol, ethane, ethene
- 26 Could polyester be made from a monomer with an acid group at one end and an alcohol group at the other end? Explain, with the aid of suitable diagrams.
- 27 Look at the structures of polyester (figure 10.14) and nylon 66 (figure 10.16) and account for the intermolecular forces between chains in these molecules. How could the properties of these polymers be expected to be different to those of polyethene?

### 10.4 Resources

- 28 While it is best to sort polymers into their particular types for recycling, some products such as tomato stakes and garden edging can be made from mixtures of polymers. Explain why this polymer product is suited to such purposes.



# 11

## Energy transformations



Humans carry out the process of respiration in order to extract energy from the food they consume. This energy is used by the body's cells to complete their necessary tasks. Power stations carry out a similar process by extracting energy from fuels to carry out tasks, whether on a small scale or a large scale. In fact, almost all chemical reactions involve an energy transformation. Generally, this energy change involves the release or absorption of heat energy. **Thermochemistry** is the study of heat changes during a chemical reaction. Whatever the situation, the total amount of energy remains constant—this is known as the **Law of Conservation of Energy**. This law states that during any chemical or physical change, energy is neither created nor destroyed; it is converted from one form to another.



The **Law of Conservation of Energy** states that energy is neither created nor destroyed, it only changes forms.



Energy is defined as the capacity to do work. Energy exists in many forms, including heat, sound, electrical, light, mechanical, elastic and chemical.



**figure 11.1** Combustion reactions release a large amount of energy.

# 11.1 Enthalpy

**Heat** is the energy transferred between two objects at different temperatures. Heat energy is measured in joules.

**Enthalpy** is the amount of heat in a system.

The delta sign  $\Delta$  means 'change in'.

**Exothermic reactions** release heat energy,  $\Delta H < 0$ .

People often confuse the concepts **heat** and **temperature**. This chapter focuses on heat, which can be defined as the energy transferred between two objects at different temperatures. Temperature, however, is a measure of the kinetic energy of the particles in an object—an increase in the temperature of a body will increase the speed at which the particles travel. Heat energy will always flow from the object with the highest temperature to the object with the lowest temperature. Heat content is dependent on mass, so it is possible to have a large body of lower temperature transfer more heat than a smaller body of higher temperature.

There is a relationship between heat and temperature. When heat energy is transferred to the body its particles begin to move faster. This transfer usually, but not always, results in an increase in temperature.

**Enthalpy** is the heat content of a system, and is given the symbol  $H$ . Enthalpy cannot be measured directly, but the change in enthalpy ( $\Delta H$ ) can.  $\Delta H$  is the difference between the enthalpies of the products and the reactants in a reaction.

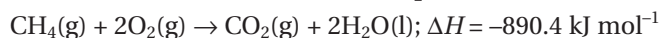
$$\Delta H = H(\text{products}) - H(\text{reactants})$$

## Exothermic and endothermic reactions

During any chemical reaction, energy is required to break the chemical bonds of the reactants. When new bonds form, energy is released, resulting in products of different chemical energy. The difference between the energy needed and the energy produced determines the direction of heat flow.

**Exothermic reactions** release energy to the surrounding environment in the form of heat. Reactions like respiration and combustion are exothermic reactions. The energy of the reactants is greater than the energy of the products, resulting in the release of heat. For an exothermic reaction, the change in enthalpy is negative, as the products have less enthalpy than the reactants.

The combustion of methane is an example of an exothermic reaction, and can be written as a **thermochemical equation**.

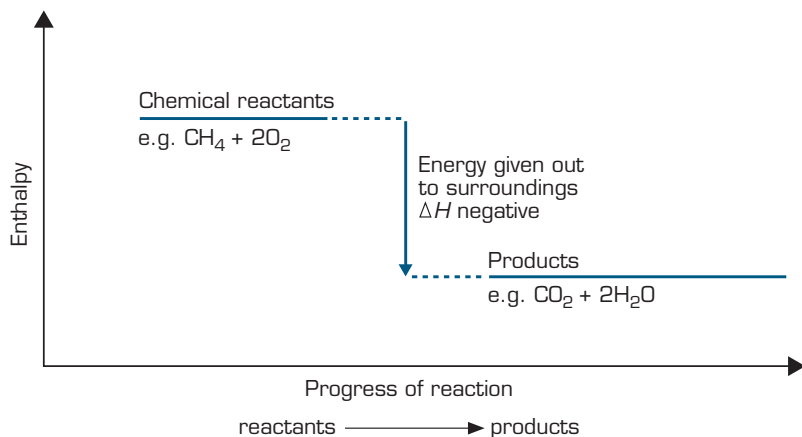


A thermochemical equation shows the value for the change in enthalpy in the reaction equation. The physical states of the reactants and products must be shown as enthalpy changes depend on physical state.

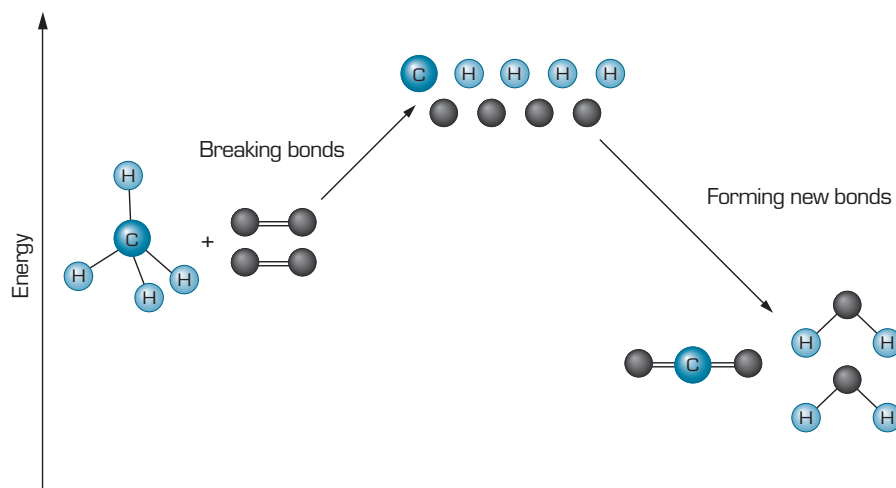
This thermochemical equation for the combustion of methane tells us that for every one mole of methane that reacts with two moles of oxygen 890.4 kJ of heat energy is released. If two moles of methane are available to react in an excess of oxygen, 1780.8 kJ of heat energy would be released. An **energy profile** can be used to show the change in energy for a reaction. The energy profile for the combustion of methane shown in figure 11.2 illustrates that the reactants methane and oxygen have a greater enthalpy than the products carbon dioxide and water. The difference represents the change in enthalpy.

For methane to combust, the bonds between carbon and hydrogen must be broken. Similarly, the bonds between the oxygen atoms in the oxygen molecule must also be broken. New bonds form to produce water and carbon dioxide. More energy is released as the new bonds form than is required to break the bonds of the reactants. This excess energy is released as heat.



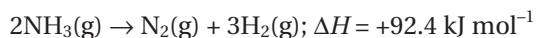


**figure 11.2** An energy profile for an exothermic reaction shows that the products have lower energy than the reactants.



**figure 11.3** The breaking and formation of bonds between methane and oxygen.

**Endothermic reactions** absorb energy from the surrounding environment. The total amount of energy of the products is greater than the energy of the reactants, so energy is required to complete the reaction. The change in enthalpy is positive. The decomposition of ammonia is an endothermic reaction. From the thermochemical equation below you can see that for every two moles of ammonia that decompose 92.4 kJ of heat energy is required. Less energy is released in the formation of new bonds than is required to break the bonds of ammonia.

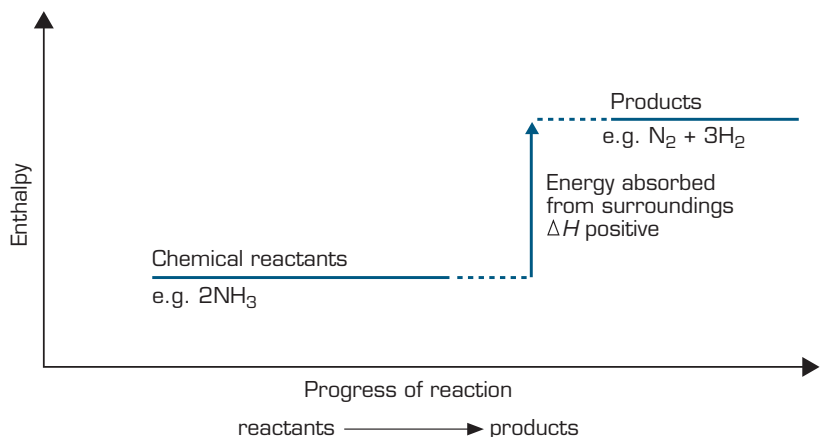


The energy profile for the decomposition of ammonia illustrates that the products, nitrogen and hydrogen, have a higher enthalpy than the reactant ammonia.



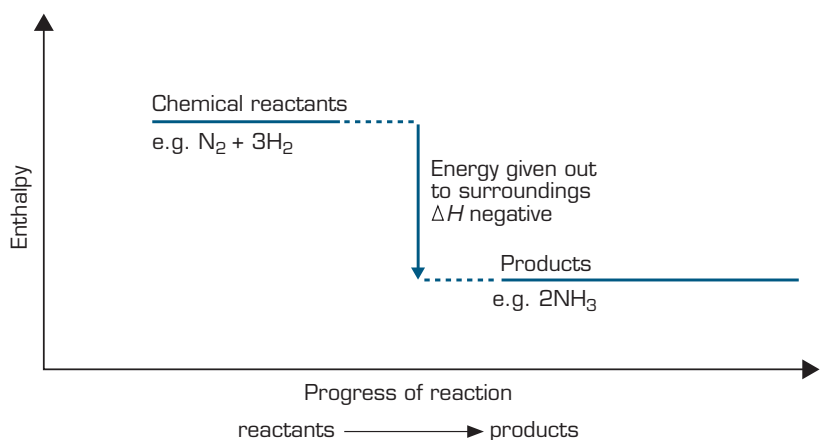
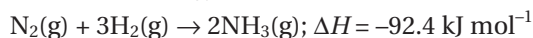
Endothermic reactions absorb heat energy,  $\Delta H > 0$ .





**figure 11.4** An energy profile for an endothermic reaction shows that the products have a higher energy than the reactants.

If nitrogen and hydrogen react to produce ammonia, the energy profile above would be reversed. Similarly, the magnitude of  $\Delta H$  would remain the same, but the sign would change. For every two moles of ammonia produced 92.4 kJ of heat energy is released.



**figure 11.5** An energy profile for the production of ammonia, an exothermic reaction.

## Latent heat

Thermochemical equations can also be written for physical processes as they also involve changes in heat energy. The heat change involved when a substance changes state is referred to as **latent heat**. For example, evaporation of one mole of water requires 44.0 kJ of heat energy and is therefore an endothermic process. For the reverse process, 44.0 kJ of heat energy is released when one mole of water condenses and so this is an exothermic process.

The thermochemical equations for these processes are given below.



Heat exchange also occurs when ice forms or melts.



**Latent heat** is the heat transfer that occurs when a substance undergoes a change in state.

The latent heat for a particular substance depends on the type of intermolecular forces—the stronger the intermolecular forces, the greater the latent heat. The hydrogen bonding in water explains water's high latent heat.



**figure 11.6** The melting of ice is an endothermic process.

**table 11.1** The latent heat values for some common molecular substances.

Substance	Latent heat of fusion (kJ mol <sup>-1</sup> )*	Latent heat of vaporisation (kJ mol <sup>-1</sup> )*
water	6.02	44.0
hydrogen	0.06	0.45
oxygen	0.22	3.4

\*The standard unit for measuring energy is the joule (J).

## Bond energies

The amount of energy required to break a bond is referred to as **bond energy**. It is an indication of the strength of the bond and also the stability of the reactants and products in a reaction. The energy required to break a bond depends on the type of elements that are bonded and whether the bond is single, double or triple. It is possible to use bond energies to estimate the change in enthalpy ( $\Delta H$ ) for a reaction by calculating the difference between the energy required to break the bonds of the reactants and the energy released when the new bonds form.

$\Delta H = \text{energy required to break bonds} - \text{energy released when new bonds form}$

**table 11.2** The energy required to break certain bonds. These values are measured when in the gaseous state.

Bond	Bond energy (kJ mol <sup>-1</sup> )	Bond	Bond energy (kJ mol <sup>-1</sup> )
H-H	432	H-F	565
C-H	413	H-Cl	427
C-C	347	H-Br	363
C=C	614	H-I	295
C≡C	839	F-F	154
C-O	351	Cl-Cl	239
C=O	745	Br-Br	193
C=O (CO <sub>2</sub> )	799	I-I	149
C≡O	1072	H-N	391
H-O	464	N-N	160
O-O	146	N=N	418
O=O	498	N≡N	941



**Bond energy** is the amount of energy required to break a bond between two atoms. Bond energy can also be referred to as **bond enthalpy**.



The breaking of bonds is an endothermic process. The formation of bonds is an exothermic process.



11



427

Energy transformations

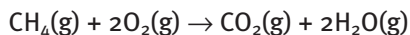


The total number of bonds must be identified, so it is helpful to draw the structures of the reactants and products to identify the number and type of bonds. You must take into account the number of each different type of bond present and also the number of moles of each.

Remember: Heat energy is absorbed or released during a change in state.

## Worked example 11.1A

Consider the combustion of methane in oxygen to form carbon dioxide and water (figure 11.3).



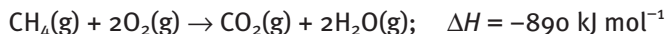
	Type of bond	Number of bonds	Bond energy (kJ mol <sup>-1</sup> )	Energy change (kJ)
reactants	C–H (CH <sub>4</sub> )	4	413	1652
	O=O (O <sub>2</sub> )	2	498	996
products	C=O (CO <sub>2</sub> )	2	799	1598
	H–O (H <sub>2</sub> O)	4	464	1856

$$\begin{aligned} \Delta H &= \text{energy required} - \text{energy released} \\ &= (1652 \text{ kJ} + 996 \text{ kJ}) - (1598 \text{ kJ} + 1856 \text{ kJ}) \\ &= -806 \text{ kJ} \end{aligned}$$

The calculated enthalpy change of  $-806 \text{ kJ}$  is only an approximation, as the bond energy value for each bond is only an average, i.e. the average energy required to break a C–H bond is  $413 \text{ kJ mol}^{-1}$ . Not all C–H bonds require  $413 \text{ kJ}$  to break the bond—some C–H bonds require more energy and some require less energy to break. In addition, the bond energy value provided for each bond is measured in the gaseous state. Water for this reaction at standard conditions would be liquid, but for this calculation it is considered to be in the gaseous state. This accounts for the difference between the calculated  $\Delta H$  and the actual  $\Delta H$ .

## Worked example 11.1B

How much energy is produced when 100 g of methane is burnt completely?



$$M(\text{CH}_4) = 12.0 + 4 \times 1.0 = 16.0 \text{ g mol}^{-1}$$

$$n(\text{CH}_4) = \frac{m}{M} = \frac{100}{16.0} = 6.25 \text{ mol}$$

From equation: 1 mol of CH<sub>4</sub> yields  $890 \text{ kJ mol}^{-1}$

$$\text{Energy produced} = 6.25 \times 890 = 5.56 \times 10^3 \text{ kJ}$$

## Questions

- Decide, giving reasons for your answer, whether the following processes are endothermic or exothermic.
  - burning of wood
  - melting of ice
  - recharging of a car battery
  - decomposition of plants in a compost heap
- Draw energy profiles to represent the following chemical reactions.
  - $\text{CO}_2(\text{g}) + \text{C}(\text{s}) \rightarrow 2\text{CO}(\text{g}); \Delta H = +161 \text{ kJ mol}^{-1}$
  - $\text{H}^+(\text{aq}) + \text{OH}^-(\text{aq}) \rightarrow \text{H}_2\text{O}(\text{l}); \Delta H = -57 \text{ kJ mol}^{-1}$
  - $6\text{CO}_2(\text{g}) + 6\text{H}_2\text{O}(\text{l}) \rightarrow \text{C}_6\text{H}_{12}\text{O}_6(\text{aq}) + 6\text{O}_2(\text{g}); \Delta H = +2803 \text{ kJ mol}^{-1}$

- 3 1 mol of lighter fluid, butane  $C_4H_{10}$ , is burned in excess oxygen according to the reaction below.  
 $2C_4H_{10}(l) + 13O_2(g) \rightarrow 8CO_2(g) + 10H_2O(l)$   
 It was experimentally determined that 2877 kJ of energy is released during this reaction. What is the energy released if 2 mol of butane is burned under the same conditions?
- 4 Propane is one of the gases in the mixture sold as LPG, for use in suitably modified cars in Australia. The thermochemical equation for the complete combustion of propane is:  
 $C_3H_8(g) + 5O_2(g) \rightarrow 3CO_2(g) + 4H_2O(l)$ ;  
 $\Delta H = -2220 \text{ kJ mol}^{-1}$   
 How much heat energy is released when 500 g of propane undergoes complete combustion?
- 5 The thermochemical equation for the complete combustion of butane is:  
 $2C_4H_{10}(g) + 13O_2(g) \rightarrow 8CO_2(g) + 10H_2O(l)$ ;  
 $\Delta H = -5772 \text{ kJ mol}^{-1}$   
 When 0.250 mol of butane undergoes complete combustion:
- A 144.0 kJ of energy is released.  
 B more energy is needed to break bonds than is released when new bonds form.  
 C 44.0 g of carbon dioxide is produced.  
 D the reaction is endothermic.
- 6 What volume of hydrogen, measured at STP, must be burnt according to the following equation in order to yield 100 kJ of heat energy? (The molar volume of any gas at STP is 22.4 L.)  
 $2H_2(g) + O_2(g) \rightarrow 2H_2O(g)$ ;  $\Delta H = -572 \text{ kJ mol}^{-1}$
- 7 Glucose is produced by photosynthesis according to the following equation:  
 $6CO_2(g) + 6H_2O(l) \rightarrow C_6H_{12}O_6(aq) + 6O_2(g)$ ;  
 $\Delta H = +2803 \text{ kJ mol}^{-1}$
- a Write a thermochemical equation for the reaction of glucose with oxygen.  
 b How much energy is released when 5.00 g of glucose is oxidised?
- 8 With reference to table 11.1, describe the trend in the amount of energy required to break a bond as the multiples of the bond increase.
- 9 How much energy is required to break the bonds for the reaction below to occur?  
 $H_2(g) + Cl_2(g) \rightarrow 2HCl(g)$
- 10 Use the bond energies in table 11.1 to calculate the approximate enthalpy change for the following reactions. State whether the reaction is exothermic or endothermic.
- a  $2H_2(g) + O_2(g) \rightarrow 2H_2O(g)$   
 b  $CH_4(g) + H_2O(g) \rightarrow 3H_2(g) + CO(g)$   
 c  $C_2H_5OH(g) + 3O_2(g) \rightarrow 2CO_2(g) + 3H_2O(g)$
- 11 Explain why using bond energies to calculate the change in enthalpy ( $\Delta H$ ) is only an approximation.

## 11.2 Specific heat capacity

Touch a metal grate on a hot day and it will feel hot, yet a nearby puddle may feel cool. The difference in the way the grate and puddle feel is due to a property called **specific heat capacity**. Specific heat capacity is the amount of heat energy required to increase the temperature of 1 g of a substance by  $1^\circ\text{C}$ . The higher the specific heat capacity of a substance the greater its ability to store heat energy, as well as its ability to release heat energy. Looking at table 11.3, you will notice that water has a high specific heat capacity. It takes nearly ten times more heat energy to raise 1 g of water by  $1^\circ\text{C}$  than it does to raise 1 g of iron by  $1^\circ\text{C}$ .

table 11.3 The specific heat capacity of various substances.

Substance	Specific heat capacity ( $\text{J g}^{-1} \text{ }^\circ\text{C}^{-1}$ )	Substance	Specific heat capacity ( $\text{J g}^{-1} \text{ }^\circ\text{C}^{-1}$ )
water	4.18	copper	0.39
ice	2.10	iron	0.45
water vapour (steam)	1.86	mercury	0.14
ethanol	2.46	silver	0.24
aluminium	0.90	cooking oil	~2.2
gold	0.13		



Specific heat capacity is the amount of heat energy required to increase the temperature of 1 gram of a substance by  $1^\circ\text{C}$ .



The specific heat capacity of water is high due to hydrogen bonding.



Good conductors of heat have a low specific heat capacity. Poor heat conductors have a high specific heat capacity.



Specific heat capacity can be represented by the following formula and has the units  $\text{J g}^{-1} \text{ } ^\circ\text{C}^{-1}$ .

$$\text{Specific heat capacity} = \frac{\text{heat energy}}{\text{mass} \times \text{change in temperature}}$$

The formula can be written more simply as:

$$s = \frac{q}{m\Delta T}$$

where  $s$  stands for specific heat,  $q$  for heat energy,  $m$  for mass and  $\Delta T$  for change in temperature.

The equation  $s = \frac{q}{m\Delta T}$  can be used to calculate the specific heat capacity of a substance.

For problems involving specific heat capacity, it is assumed that the density of water is  $1.00 \text{ g mL}^{-1}$ . For this problem, the 250 mL of water would have a mass of 250 g.

## Worked example 11.2A

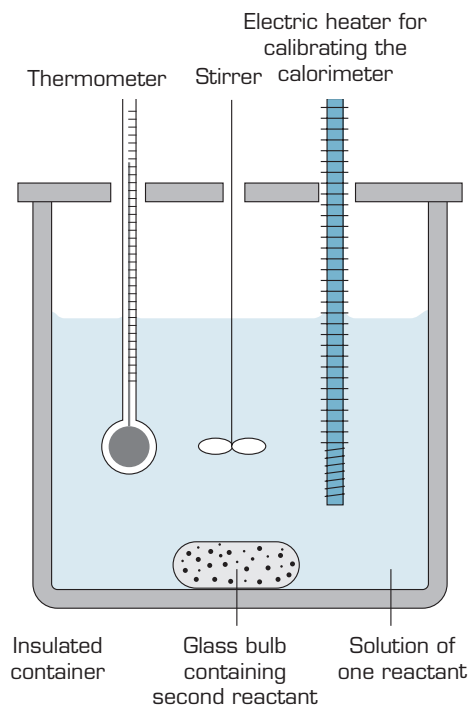
Calculate the amount of heat energy needed to heat 250 mL of water in a kettle to  $100^\circ\text{C}$  if the initial water temperature is  $25.0^\circ\text{C}$ .

$$\begin{aligned} \text{heat} &= \text{mass} \times \text{specific heat capacity} \times \text{change in temperature} \\ &= 250 \text{ g} \times 4.18 \text{ J g}^{-1} \text{ } ^\circ\text{C}^{-1} \times (100.0^\circ\text{C} - 25.0^\circ\text{C}) \\ &= 78\,375 \text{ J} \end{aligned}$$

The amount of heat energy needed is  $7.84 \times 10^1 \text{ kJ}$ .

## Calorimetry—measuring heat of reaction

The heat exchange that takes place during a chemical reaction is measured using a technique called **calorimetry**. The heat exchange is measured using an instrument called a calorimeter. Calorimeters are insulated containers designed to reduce heat loss to or heat gain from the environment. There are different types of calorimeters, depending on the physical states of the reactants. Figure 11.7 shows the set-up when the reaction takes place in an aqueous solution. It is called a constant pressure calorimeter. The initial temperatures of the solutions and the final temperature of the mixture are measured. This change in temperature, together with the mass and the specific heat capacity of the mixture, can be used to determine the change in enthalpy for the reaction.



**figure 11.7** A constant pressure calorimeter measures the heat change in an aqueous chemical reaction. The reaction is started when the glass bulb breaks.

**Calorimetry** is the measurement of heat changes in a reaction.

The heat of reaction when a specified amount of a substance is burned completely is known as the **heat of combustion**.

### Worksheet 1

Exothermic and endothermic reactions

### Worksheet 2

Energy changes

ENERGY CHANGES

430

+

# Experiment 11.1

## Molar heat of a chemical reaction

### Purpose

To calculate the heats of reaction accompanying several chemical reactions using a simple calorimeter.

### Method A: Precipitation reaction

- 1 Measure exactly 100 mL magnesium chloride solution and place it in a clean, dry styrofoam cup. Record the temperature to the nearest  $0.5^{\circ}\text{C}$ .
- 2 Into a clean, dry measuring cylinder measure exactly 100 mL sodium carbonate solution. Record its temperature to the nearest  $0.5^{\circ}\text{C}$ .
- 3 Transfer the sodium carbonate solution slowly into the cup containing the magnesium chloride, stirring and recording the temperature continuously.
- 4 Keep recording the temperature until the maximum difference in temperature is reached.

### Calculations

- 1 Calculate the maximum temperature change,  $\Delta T$ , due to the reaction. (If both solutions are not at the same temperature before mixing, take the average of the initial temperatures of the two solutions.)
- 2 Assume that 200 mL of mixture has the same heat capacity as 200 mL of water. Using the relationship  
heat = mass  $\times$  specific heat capacity  $\times$  change in temperature  
calculate the amount of heat energy associated with the precipitation reaction.
- 3 Assuming there is no solution in excess, calculate:
  - a the number of moles of magnesium chloride used (this is equal to the number of moles of magnesium carbonate precipitated)
  - b the heat energy change,  $\Delta H$ , when 1 mole of magnesium carbonate is precipitated.

### Discussion

- 1 Write a balanced net ionic equation for the precipitation reaction including the calculated quantity of heat energy.
- 2 Draw an energy profile diagram for the above reaction, clearly indicating your measured quantity of heat energy change (that is, enthalpy).
- 3 Is this precipitation reaction exothermic or endothermic? Explain in terms of bonds breaking and forming.

### Method B: Reaction of magnesium with acid

- 1 Weigh a 3 cm piece of magnesium ribbon and determine its mass. (Depending on the accuracy of the balance, you may need to weigh a 1 m length of ribbon and calculate the mass of 3 cm.)
- 2 Using a measuring cylinder, transfer exactly 100 mL 2 M hydrochloric acid into a clean, dry styrofoam cup. Record its initial temperature.
- 3 Drop the piece of magnesium ribbon into the cup and stir the mixture with the thermometer. Record the maximum difference in temperature.

### materials

- 100 mL of the following 1 M solutions:
  - magnesium chloride
  - sodium hydroxide
  - potassium hydroxide
  - hydrochloric acid
  - nitric acid
  - sodium carbonate
- styrofoam cups
- measuring cylinder
- thermometer ( $-10$  to  $100^{\circ}\text{C}$ )
- glass rod
- 3 cm magnesium ribbon
- small ruler
- 100 mL 2 M hydrochloric acid solution
- datalogger with temperature probe
- electronic balance

### safety

- Wear safety glasses and a laboratory coat for this experiment.
- Acids and bases are corrosive.



431

Energy transformations



11

## Calculations

- 1 Calculate the temperature change,  $\Delta T$ .
- 2 Using the relationship given in Method A, calculate the heat energy associated with your reaction. (Assume that 100 mL hydrochloric acid has the same heat capacity as 100 mL water.)
- 3 Calculate the number of moles of magnesium used.
- 4 Calculate the heat energy involved when 1 mole of magnesium reacts with hydrochloric acid.

## Discussion

- 1 Write a fully balanced chemical equation for the reaction, including the measured heat change,  $\Delta H$ .
- 2 Draw an energy profile diagram for your reaction, clearly indicating the measured quantity of molar heat energy change.
- 3 Do the reactants or the products have more stored energy? Explain.

## Method C: Neutralisation reactions (datalogger)

- 1 Measure 100 mL of a selected 1 M acid solution and record its temperature.
- 2 Using another measuring cylinder, transfer 100 mL of a selected base into a clean, dry styrofoam cup. Record its initial temperature using a temperature probe and datalogger.
- 3 Pour the acid into the base. Keep recording the temperature change using the probe and datalogger.
- 4 Print out a graph of temperature change from the datalogger. Record the biggest difference in temperature.

## Calculations

- 1 Calculate the temperature change,  $\Delta T$ , for the reaction. (If the initial temperature of the acid and base solutions are not the same, take the average initial reading.)
- 2 Assume that the reaction mixture has the same heat capacity as 200 mL water. Using the relationship given in Method A, calculate the heat energy associated with precipitation reaction.
- 3 Assuming that the reaction was carried out with no excess of either reactant, calculate:
  - a the number of moles of acid neutralised
  - b the heat energy released when 1 mole of acid is neutralised ( $\Delta H$  in  $\text{kJ mol}^{-1}$ ).

## Discussion

- 1 Write a fully balanced chemical equation for your reaction, including the measured  $\Delta H$ .
- 2 Write a net ionic equation for your reaction.
- 3 Explain why four different reactions have almost identical enthalpy values.
- 4 What would be the  $\Delta H$  value if 0.1 mol sulfuric acid is completely neutralised with potassium hydroxide?
- 5 Discuss the sources of error associated with using this simple calorimeter.



## Questions

12 Using table 11.4, calculate the energy needed to heat:

- a 100 mL of water from 20.0°C to 80.0°C
- b 250 mL of water from 25.0°C to 100.0°C
- c 1.5 kg of water from 20.0°C to 30.0°C
- d 300 g of water from 18.0°C to 100.0°C
- e 300 g of cooking oil from 18.0°C to 100.0°C.

table 11.4

Substance	Specific heat capacity ( $\text{J g}^{-1} \text{ } ^\circ\text{C}^{-1}$ )
water	4.18
cooking oil	~2.2
ethanol	2.46
iron	0.45
copper	0.39
aluminium	0.90
sand	0.48

13 500 mL of water in an electric kettle was heated using 136 kJ of electrical energy. If the water was initially at 15°C, calculate its final temperature.

14 A Bunsen burner was used to heat 500 g of water. The temperature of the water rose by 5.0°C when 0.270 L of methane (measured at STP molar volume of any gas is 22.4 L) was used.

- a How much heat energy was transferred to the water?
- b How many moles of methane were consumed?
- c Write a balanced equation for the combustion of methane.
- d Calculate  $\Delta H$  for the reaction described by the equation written in part c.
- e Give two reasons why the value for  $\Delta H$  that has been determined in this experiment differs from the literature value of  $-890 \text{ kJ mol}^{-1}$ .

15 Consider table 11.4, which shows heat capacities of common materials. On a hot day a swimmer leaves the water, walks across the sand and, when entering a car, sits on the metal buckle of the seat belt. Explain how the data in the table is related to the swimmer's experiences.

16 Sand and water are both used to smother fires. Which material would absorb the most heat from a fire? Why?

17 A 0.254 g sample of black coal was burnt in a bomb calorimeter. The calorimeter contained 300 mL of water which rose from 18.25°C to 24.92°C.

- a Using the specific heat capacity of water, calculate the heat of combustion of the coal.
- b Is your answer likely to be higher or lower than the actual value? Explain.

## 11.3 Spontaneous reactions

Iron, when exposed to air and moisture, will rust to form iron oxide. This reaction always takes place, no matter how slowly, and is said to take place spontaneously. A **spontaneous reaction** is a reaction that will occur under a given set of conditions. Just because a process can be described by a balanced chemical equation doesn't mean that chemical reaction will occur. Appropriate conditions need to be applied that allow a chemical reaction to take place. A reaction is **non-spontaneous** if it does not occur under the given set of conditions. The two factors that need to be taken into account when determining whether a reaction is spontaneous or not are the changes in enthalpy and entropy.

### Enthalpy

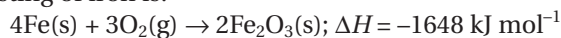
One of the factors that may indicate whether a reaction will occur spontaneously is the enthalpy change. The release of heat in an exothermic reaction ( $-\Delta H$ ) results in a lower total energy of a system. This is a favourable



A **spontaneous reaction** is a reaction that will occur under a given set of conditions. A **non-spontaneous reaction** will not occur under a given set of conditions.



result and therefore the fact that a reaction is exothermic may indicate that the reaction tends to occur spontaneously. The thermochemical equation for the rusting of iron is:



The negative  $\Delta H$  value indicates that enthalpy change favours this reaction.

The opposite is true for endothermic reactions. A positive  $\Delta H$  indicates an unfavourable increase in the total energy of the products.

## Entropy

The change in enthalpy cannot solely predict the spontaneity of a reaction. Another determining factor is **entropy (S)**. Entropy is a measure of the randomness or disorder of a system. The greater the entropy of a system, the greater the disorderly distribution of atoms, molecules or ions. A system of low entropy is very ordered and requires greater energy to maintain this order than a system of high entropy. Low entropy is therefore said to be unfavourable and high entropy to be favourable.

To determine the change in entropy for a system, the following points need to be taken into consideration.

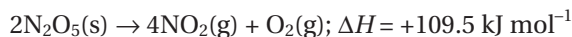
- 1 The entropy of a gas is much greater than that of a liquid and solid. Solids have low entropies due to their ordered structure. Gases have high entropies as the particles are moving very fast and in a random manner. A reaction where gaseous products are formed from solid or liquid reactants results in increased entropy.
- 2 Entropy increases when a reactant is divided into smaller parts and when there are more moles of products than moles of reactants. Decomposition reactions result in an entropy increase.

Reaction conditions can also alter the entropy of a system. Entropy increases with temperature. The faster the particles are moving, the greater entropy the system will have as the particles are moving more randomly and chaotically.

## Predicting spontaneity

Predicting the spontaneity of a reaction is sometimes difficult. The rusting of iron described above involves the reaction of a gaseous reactant with a solid reactant and the formation of only a solid product. This results in a decrease in entropy, which is unfavourable. The reaction is spontaneous, however, as the decrease in entropy (unfavourable) is offset by the decrease in enthalpy of the exothermic reaction (favourable). It is possible for an exothermic reaction to be non-spontaneous if the decrease in entropy is too great.

An endothermic reaction (unfavourable) may be spontaneous if it is offset by a large increase in entropy (favourable). For example, crystalline dinitrogen pentoxide is very unstable and will rapidly and spontaneously decompose:



This is an endothermic process but it results in products of greater entropy. There are a greater number of moles of products formed, and gaseous products are formed from a solid reactant. The result is a large increase in entropy.

Table 11.5 summarises the likelihood of a process being spontaneous, considering changes in enthalpy and entropy.

Entropy is the measure of disorder of a system.

To understand the change in entropy for a reaction it is important to show the physical states of reactants and products.

The change in entropy is positive (+ $\Delta S$ ) if entropy increases for a reaction, and is negative (- $\Delta S$ ) if entropy decreases.

- $\Delta H$  exothermic reaction  
+ $\Delta H$  endothermic reaction  
+ $\Delta S$  increase in entropy  
- $\Delta S$  decrease in entropy

**table 11.5** Spontaneity of a reaction depends on enthalpy and entropy changes.

Conditions	Result
$\Delta S$ positive, $\Delta H$ negative	An increase in entropy and decrease in enthalpy both favour the reaction. The reaction will occur spontaneously.
$\Delta S$ negative, $\Delta H$ positive	A decrease in entropy and increase in enthalpy both oppose the reaction. The reaction will be non-spontaneous.
$\Delta S$ positive, $\Delta H$ positive	An increase in entropy favours the reaction and an increase in enthalpy opposes it. The reaction may be spontaneous depending on the dominant factor.
$\Delta S$ negative, $\Delta H$ negative	A decrease in entropy opposes the reaction and an increase in enthalpy favours it. The reaction may be spontaneous depending on the dominant factor.

**Worksheet 3**  
Spontaneous reactions

When the changes in enthalpy and entropy oppose each other, the reaction conditions may be set so that a factor dominates to allow the reaction to proceed.

For a reaction in which an increase in entropy and an increase in enthalpy oppose each other, high temperatures may allow the reaction to take place. At high temperatures the components of the reaction have higher entropy and this factor may dominate in an endothermic reaction.

For a reaction where a decrease in entropy and an increase in enthalpy oppose each other, low temperatures may allow the reaction to take place. At low temperatures the change in enthalpy may be more significant and this factor may dominate in an exothermic reaction.

## Questions

- 18** Which one of each pair has the higher entropy? Explain your choice.
- $\text{CO}_2(\text{g})$ ,  $\text{CO}_2(\text{s})$
  - $\text{H}_2\text{O}(\text{l})$ ,  $\text{H}_2\text{O}(\text{s})$
  - $\text{H}_2\text{O}$  at  $30^\circ\text{C}$ ,  $\text{H}_2\text{O}$  at  $80^\circ\text{C}$
  - $\text{NaCl}(\text{aq})$ ,  $\text{NaCl}(\text{s})$
- 19** For each of the following changes, state whether entropy would increase or decrease. Give reasons for your answer.
- $\text{CaCO}_3(\text{s}) \rightarrow \text{CaO}(\text{s}) + \text{CO}_2(\text{g})$
  - $\text{H}_2\text{O}(\text{g}) \rightarrow \text{H}_2\text{O}(\text{l})$
  - $4\text{P}(\text{s}) + 5\text{O}_2(\text{g}) \rightarrow \text{P}_4\text{O}_{10}(\text{s})$
  - $2\text{NO}(\text{g}) + \text{O}_2(\text{g}) \rightarrow 2\text{NO}_2(\text{g})$
- 20** Predict the spontaneity for each of the following reactions. Explain your answer.
- $\text{FeO}(\text{s}) + \text{H}_2(\text{g}) \rightarrow \text{Fe}(\text{s}) + \text{H}_2\text{O}(\text{l})$ ;  
 $\Delta H = +22 \text{ kJ mol}^{-1}$
  - $\text{C}_3\text{H}_8(\text{g}) + 5\text{O}_2(\text{g}) \rightarrow 3\text{CO}_2(\text{g}) + 4\text{H}_2\text{O}(\text{g})$ ;  
 $\Delta H = -2220 \text{ kJ mol}^{-1}$
  - $\text{P}_4(\text{s}) + 6\text{Cl}_2(\text{g}) \rightarrow 4\text{PCl}_3(\text{g})$ ;  $\Delta H = -1226 \text{ kJ mol}^{-1}$
  - $\text{H}_2\text{O}(\text{s}) \rightarrow \text{H}_2\text{O}(\text{l})$ ;  $\Delta H = +6.02 \text{ kJ mol}^{-1}$
  - $\text{CO}_2(\text{g}) \rightarrow \text{C}(\text{s}) + \text{O}_2(\text{g})$ ;  $\Delta H = +393.5 \text{ kJ mol}^{-1}$



## Summary ▶▶▶▶

- ▶ Heat changes accompany reactions, although the total energy of a system always remains constant according to the **Law of Conservation of Energy**.
- ▶ **Heat** is the energy transferred between two objects at different temperatures. **Temperature** is a measure of the kinetic energy of the particles in an object.
- ▶ **Enthalpy** is the total heat content of a substance. Only the change in enthalpy ( $\Delta H$ ) can be measured directly.
- ▶ **Exothermic reactions** release heat energy and have a negative  $\Delta H$ , as the products have lower energy than the reactants.
- ▶ **Endothermic reactions** absorb heat energy and have a positive  $\Delta H$ , as the products have higher energy than the reactants.
- ▶ **Thermochemical equations** are used to describe the heat changes that occur during a chemical reaction. **Energy profiles** can be used to visually represent enthalpy changes during a reaction.
- ▶ Heat changes also occur during physical changes. The amount of heat absorbed or released during a change in state is called **latent heat**.
- ▶ **Bond energy** is the amount of energy required to break a bond between two atoms.
- ▶ **Specific heat capacity** is a measure of the amount of heat energy required to increase the temperature of 1 gram of a substance by 1°C. It can be determined using the formula:  
$$\text{specific heat} = \frac{\text{heat energy}}{\text{mass} \times \text{change in temperature}}$$
- ▶ **Calorimetry** is an experimental technique to measure the change in heat that occurs during a chemical reaction.
- ▶ **Entropy** is a measure of the disorder of a system and can increase or decrease during a chemical reaction. An increase in entropy favours a reaction proceeding.
- ▶ **Spontaneous reactions** are those that occur under a given set of conditions. The spontaneity of a reaction can be predicted by whether enthalpy and entropy factors favour or oppose that process.

## Key terms ▶▶

bond energy

calorimetry

endothermic reaction

energy profile

enthalpy

entropy

exothermic reaction

heat

latent heat

Law of Conservation of Energy

non-spontaneous reaction

specific heat capacity

spontaneous reaction

temperature

thermochemical equation

11



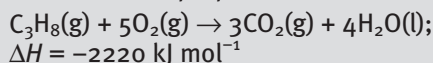
## Chapter Review

### 11.1 Enthalpy

- 21 Methane,  $\text{CH}_4$ , is the principal constituent of natural gas used for cooking and heating. In the chemical reaction that occurs when methane burns:

A  $\Delta H > 0$   
B  $H_{\text{products}} > H_{\text{reactants}}$   
C  $\Delta H < 0$   
D  $H_{\text{reactants}} < 0$

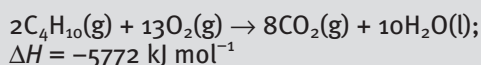
- 22 Propane is one of the gases in the mixture sold as LPG, for use in suitably modified cars in Australia. The thermochemical equation for the complete combustion of propane is:



During this reaction:

- A less energy is needed to break bonds than is released when new bonds form.  
B more energy is needed to break bonds than is released when new bonds form.  
C less energy is released as bonds are broken than is used up when new bonds form.  
D more energy is released as bonds are broken than is used up when new bonds form.

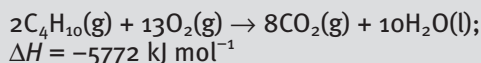
- 23 The thermochemical equation for the complete combustion of butane is:



When 500 g of butane reacts completely, according to this reaction, the amount of energy released is closest to:

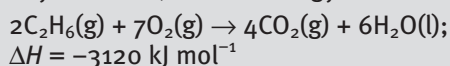
- A  $2.48 \times 10^4 \text{ kJ}$ .  
B  $4.96 \times 10^4 \text{ kJ}$ .  
C  $9.93 \times 10^4 \text{ kJ}$ .  
D  $2.89 \times 10^4 \text{ kJ}$ .

- 24 The thermochemical equation for the complete combustion of butane is:



A saucepan of water is heated on a camping gas stove that uses a butane gas burner. Assuming that 35% of the heat energy released is transferred to the water, what amount, in mol, of butane must burn to supply 5772 kJ of energy to the water?

- 25 What volume of ethane, measured at STP, must be burnt according to the following equation in order to yield 100 kJ of heat energy?



The following information is referred to in questions 26 and 27.

Two gaseous fuels that have been investigated as possible alternative energy sources are hydrogen gas,  $\text{H}_2$ , and biogas, which consists mostly of methane,  $\text{CH}_4$ . Table 11.6 shows the energy released by the combustion of 1 mol of hydrogen and methane.

table 11.6

Fuel	Equation for combustion reaction	Energy released per mole of fuel ( $\text{kJ mol}^{-1}$ )
hydrogen	$\text{H}_2(\text{g}) + \text{O}_2(\text{g}) \rightarrow \text{H}_2\text{O}(\text{l})$	286
methane	$\text{CH}_4(\text{g}) + 2\text{O}_2(\text{g}) \rightarrow \text{CO}_2(\text{g}) + 2\text{H}_2\text{O}(\text{l})$	890

- 26 From the information above it can be deduced that:
- A biogas is preferred to hydrogen as a fuel when greenhouse gas emissions are considered.  
B if equal amounts (in moles) of the two gases are stored, hydrogen gas is the preferred fuel.  
C if equal volumes of the two gases are stored, hydrogen gas is the preferred fuel.  
D if equal masses of the two fuels are stored, hydrogen gas is the preferred fuel.
- 27 Calculate the heat evolved when 25.00 mL of 0.100 M sulfuric acid reacts with excess sodium hydroxide solution.
- $$\text{H}_2\text{SO}_4(\text{aq}) + 2\text{NaOH}(\text{aq}) \rightarrow \text{Na}_2\text{SO}_4(\text{aq}) + 2\text{H}_2\text{O}(\text{l});$$
- $$\Delta H = -57.2 \text{ kJ mol}^{-1}$$
- 28 Ethanol produced from sugar is used as a substitute for petrol in Brazil. The heats of combustion of ethanol ( $\text{CH}_3\text{CH}_2\text{OH}$ ) and octane ( $\text{C}_8\text{H}_{18}$ ), a major component of petrol, are  $1367 \text{ kJ mol}^{-1}$  and  $5450 \text{ kJ mol}^{-1}$  respectively.
- a Write thermochemical equations to represent the combustion reactions of ethanol and octane.  
b Calculate the heats of combustion of each fuel in units of  $\text{kJ g}^{-1}$ .  
c If the fuels were the same price per gram, which fuel would represent the better value?  
d In 1981 a blend of petrol and 15% ethanol called Petranol was sold to Queensland motorists. Would cars using Petranol travel a further or shorter distance per tank than those using petrol?

e Comment on the prospect of replacing petrol with ethanol produced from sugar and using it as fuel for cars in the future.

29 Use the bond energies in table 11.1 to calculate the approximate enthalpy change for the following reactions.

- a  $\text{CO(g)} + 2\text{H}_2\text{(g)} \rightarrow \text{CH}_3\text{OH(g)}$   
 b  $\text{N}_2\text{(g)} + 3\text{H}_2\text{(g)} \rightarrow 2\text{NH}_3\text{(g)}$

## 11.2 Specific heat capacity

30 Consider table 11.7, which shows heat capacities of common materials. By referring to this table, calculate the energy required to raise the temperature of:

- a 1.00 kg of iron from 25.0 to 100.0°C  
 b 500 g of water from 25.0 to 100.0°C  
 c 0.500 kg of ethanol from 50.0 to 100.0°C  
 d 500 g of aluminium from 50.0 to 100.0°C.

table 11.7

Substance	Specific heat capacity ( $\text{J g}^{-1} \text{ } ^\circ\text{C}^{-1}$ )
water	4.18
cooking oil	~2.2
ethanol	2.4
iron	0.45
copper	0.39
aluminium	1.97
sand	0.48

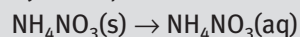
31 As part of an investigation into the chemistry of the cold packs included in sports first-aid kits, a student conducted an experiment during which a sample of ammonium nitrate,  $\text{NH}_4\text{NO}_3$ , was dissolved in water in a polystyrene cup. The temperature change that occurred was measured. The data recorded by the student is shown in table 11.8.

table 11.8

mass of $\text{NH}_4\text{NO}_3\text{(g)}$	3.05
mass of solution (g)	100
initial temperature ( $^\circ\text{C}$ )	16.2
final temperature ( $^\circ\text{C}$ )	14.5

a Calculate the amount of heat energy absorbed by the ammonium nitrate as it dissolved, given that the specific heat capacity of the solution is  $4.18 \text{ J } ^\circ\text{C}^{-1} \text{ g}^{-1}$ .

b Using the student's data, calculate  $\Delta H$ , in  $\text{kJ mol}^{-1}$ , for the dissolution process described by the equation



32 Figure 11.8 shows the design of a bomb calorimeter, which can be used to measure the energy content of fuels and foods. The fuel or food is ignited in the internal chamber (X) and the heat that is released causes the water temperature (in Y) to rise.

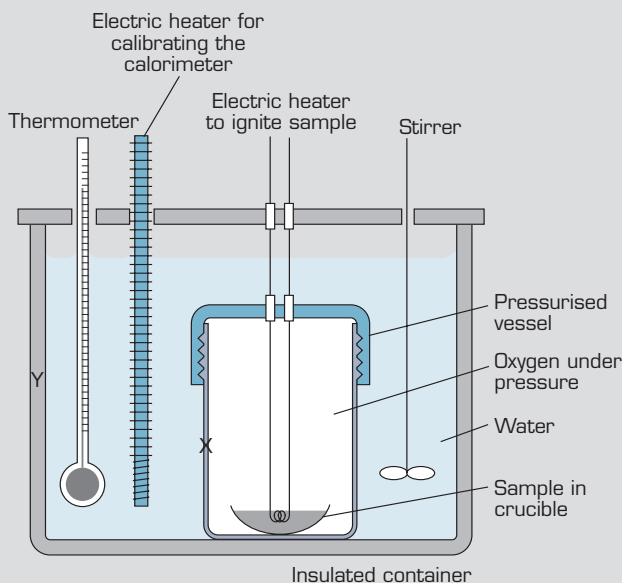
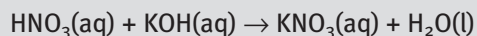


figure 11.8

Insulation would be essential in the walls of:

- A both X and Y.  
 B X but not Y.  
 C Y but not X.  
 D neither X nor Y.

33 When nitric acid and potassium hydroxide are mixed an exothermic reaction occurs.



Two experiments were conducted in a well-insulated container, using solutions of nitric acid and potassium hydroxide that had the same initial temperature.

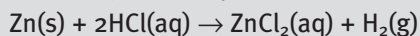
In experiment 1, 50.0 mL of 0.100 M nitric acid solution is mixed with 50.0 mL of 0.100 M potassium hydroxide solution. The temperature change was measured.

In experiment 2, 25.0 mL of 0.100 M nitric acid solution is mixed with 25.0 mL of 0.100 M potassium hydroxide solution. The temperature change was again measured.

Compared to experiment 1, experiment 2 will release:

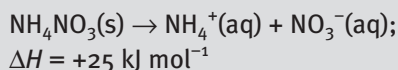
- A twice as much heat energy.
- B the same amount of heat energy.
- C half as much heat energy.
- D a quarter as much heat energy.

- 34 Metallic zinc reacts with hydrochloric acid according to the equation:



Describe an experiment that would allow the enthalpy change for this reaction,  $\Delta H$ , to be determined. Clearly indicate how the experiment is performed, what experimental data would need to be collected, and how this data is used to calculate  $\Delta H$ .

- 35 An indoor swimming pool is to be heated by burning methane gas. Because the surface is exposed to the air and the sides of the pool are poorly insulated, some of the heat supplied will be lost to the surroundings.
- a Write a balanced chemical equation for the complete combustion of methane gas,  $\text{CH}_4$ .
  - b Calculate the amount of heat energy needed to heat the pool from  $11.0^\circ\text{C}$  to  $25.0^\circ\text{C}$ , using the following assumptions.
    - The volume of the pool is  $90.0 \text{ m}^3$ .
    - The pool water has a density of  $1000 \text{ kg m}^{-3}$ .
    - It takes  $4.18 \text{ kJ}$  of energy to raise the temperature of  $1.00 \text{ kg}$  of water by  $1.00^\circ\text{C}$ .
    - 45% of the heat released by burning the methane is lost to the surroundings in the time it takes to heat the water from  $11.0^\circ\text{C}$  to  $25.0^\circ\text{C}$ .
  - c If the heat of combustion of methane is  $890 \text{ kJ mol}^{-1}$ , calculate the volume of methane, measured at  $11.0^\circ\text{C}$  and  $101.3 \text{ kPa}$  that needs to be burned.
- 36 An instant cold pack sold for the treatment of sporting injuries contains solid ammonium nitrate and a weak inner plastic bag full of water. Punching the pack breaks the inner bag and causes the ammonium nitrate to dissolve.



A bag containing  $25.0 \text{ g}$  of ammonium nitrate was punched and dropped into a  $2.00 \text{ L}$  container of water at a temperature of  $19.00^\circ\text{C}$ .

- a Calculate the lowest temperature that the water could reach.
  - b Why would this temperature not be achieved in practice?
- 37 A hot piece of copper at  $100.0^\circ\text{C}$  was cooled in  $500 \text{ mL}$  of water. The temperature of the water before the copper was added was  $20.0^\circ\text{C}$ . If the temperature of the water rose to  $25.0^\circ\text{C}$ , calculate the mass of the copper.

## 11.3 Spontaneous reactions

- 38 How does the entropy change for each of the following physical processes?
- a a liquid solidifies
  - b a gas condenses
  - c a solid sublimates
  - d a solid melts
  - e a liquid freezes
  - f a liquid boils
- 39 Predict the change in entropy for each reaction, giving reasons for your prediction.
- a  $\text{NH}_3\text{(g)} + \text{HCl(g)} \rightarrow \text{NH}_4\text{Cl(s)}$
  - b  $2\text{NaHCO}_3\text{(s)} \rightarrow \text{Na}_2\text{CO}_3\text{(s)} + \text{H}_2\text{O(l)} + \text{CO}_2\text{(g)}$
  - c  $2\text{KClO}_4\text{(s)} \rightarrow 2\text{KClO}_3\text{(s)} + \text{O}_2\text{(g)}$
  - d  $\text{H}_2\text{(g)} + \text{Br}_2\text{(g)} \rightarrow 2\text{HBr(g)}$
- 40 Predict the spontaneity for each of the following reactions. Explain your answers.
- a  $2\text{SO}_2\text{(g)} + \text{O}_2\text{(g)} \rightarrow 2\text{SO}_3\text{(g)}$ ;  $\Delta H = -198 \text{ kJ mol}^{-1}$
  - b  $\text{C(s)} + \text{O}_2\text{(g)} \rightarrow \text{CO}_2\text{(g)}$ ;  $\Delta H = -393.5 \text{ kJ mol}^{-1}$
  - c  $\text{CH}_4\text{(g)} + \text{H}_2\text{O(g)} \rightarrow \text{CO(g)} + 3\text{H}_2\text{(g)}$ ;  $\Delta H = +206 \text{ kJ mol}^{-1}$
  - d  $\text{C}_6\text{H}_{12}\text{O}_6\text{(g)} + 6\text{O}_2\text{(g)} \rightarrow 6\text{CO}_2\text{(g)} + 6\text{H}_2\text{O(g)}$ ;  $\Delta H = -2815 \text{ kJ mol}^{-1}$



# 12

## Qualitative and quantitative testing

### 12.1 Testing a sample

It has become increasingly important to our society to understand the nature of the substances we consume or make use of in our daily lives. Many products have labels which show the type and amount of chemicals that they contain. Testing a sample to identify the chemicals contained in it is known as **qualitative analysis**. Testing a sample to find out the amounts of the chemicals it is composed of is known as **quantitative analysis**. Qualitative and quantitative analyses prove invaluable in many areas. Some of these include monitoring of consumer goods and water quality, solving crimes, detecting disease and monitoring levels of pollution in the environment.



**figure 12.1** Qualitative and quantitative tests are carried out on the air samples collected by the CSIRO plane near a coal-fired power station to monitor the gas emissions from the power station.



In this chapter we will be focussing on qualitative analysis, which allows us to examine a substance and identify the type of chemicals it contains. The type of testing performed can vary from using simple laboratory techniques to rigorous testing using hi-tech devices which are only available to industry and research facilities. This is often because they are quite expensive and can need specially trained technicians to operate them correctly.

Some of the simpler techniques easily performed in the laboratory are discussed below.



**Qualitative analysis** is carried out to determine the components of a chemical sample.

## Questions

- 1 Explain whether each of the following is an example of qualitative analysis or quantitative analysis:
  - a the determination of a person's blood group from a sample
  - b a blood alcohol reading taken by a random breath testing unit
  - c the nutritional information on the label of a chocolate bar
  - d the detection of unsafe levels of mercury in fish.
- 2 The label on a can of spaghetti lists its ingredients as follows: spaghetti, tomato sauce, sugar, salt, food acid, cheese, spice extract, flavour and natural colour.
  - a Explain whether this is an example of quantitative analysis or qualitative analysis.
  - b Describe what type of information would be needed to make it the other type of analysis.

## 12.2 The flame test

Many metals have a distinctive colour when heated in a flame due to the arrangement of their electrons. Heating the metal ions gives their electrons enough energy to move into higher energy levels. As the electrons return to lower energy levels they give off energy (light) of a distinctive colour.

The **flame test** of Experiment 12.1 demonstrates the distinctive colours of some metallic elements. During this experiment the Bunsen burner flame supplies sufficient energy to the metal ions to cause electrons to jump from one energy level to a higher one. The **excited state** of these electrons is very unstable and they quickly drop back to a lower energy level, emitting energy in the process. The energy emitted has a fixed value equal to the difference between the higher energy level and the lower energy level. If the energy emitted lies within the visible range it can be seen as light of a particular colour and of a specific wavelength.

We see examples of this when watching fireworks displays. When making the fireworks, small amount of particular metals are added to the mixture to produce particular colours. For example, strontium metal produces a vivid red colour (more properly called scarlet).

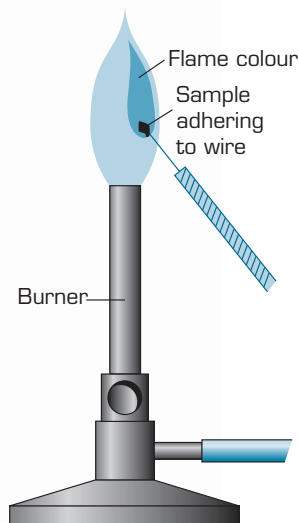


The **flame test** is a qualitative procedure which can determine the presence of a particular metal ion by the colour of light emitted when a sample is placed into the flame of a Bunsen burner.

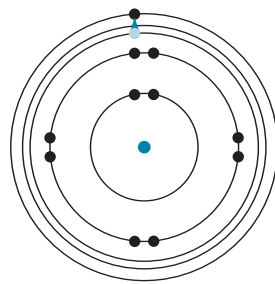


The lowest energy level a particular electron can be in is known as the **ground state**.

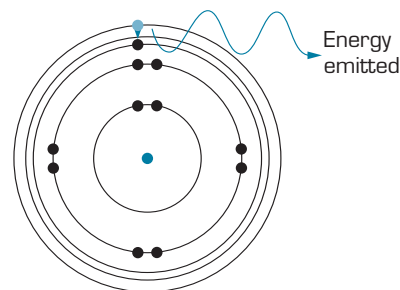




**figure 12.3** An alternative method of flame testing to that shown in Experiment 12.1. A moist platinum wire is dipped into the sample to be tested then placed into the hottest part of the flame.



Energy from the flame promotes an electron to a higher energy level.



The electron quickly returns to a lower energy level, emitting light of a particular colour.

**figure 12.2** Electrons moving between energy levels gives the distinctive colours seen in flame tests.

For any element, there are likely to be several possible movements of electrons between lower and higher energy levels and so the flame colour is probably a combination of colours corresponding to these transitions.

Flame tests are of limited value as the colours observed are often similar for different elements (table 12.1). However the principles of this method have been used to develop more sophisticated techniques which give more reliable results.

**table 12.1** Flame colours of some metals.

Metal	Flame colour	Metal	Flame colour
sodium	yellow	lithium	crimson
strontium	scarlet	calcium	red
copper	green	potassium	lilac
barium	yellow-green		

## Experiment 12.1

### Flame test

#### materials

- 100 mL of 2 M hydrochloric acid
- small quantities of barium carbonate, calcium carbonate, copper carbonate, potassium carbonate, sodium carbonate and strontium carbonate
- bench mat
- evaporating dish
- 250 mL beaker
- spatula
- Bunsen burner

*This experiment may best be performed in stations, with one carbonate per station and groups of students rotating through each station.*

#### Purpose

To observe the distinctive flame colours of some metallic elements.

#### Method

- 1 Place the evaporating dish on top of the beaker on the bench mat.
- 2 Use the spatula to transfer a small amount of one of the carbonates to the evaporating dish.
- 3 Add approximately 5 mL of hydrochloric acid to the evaporating dish and direct the non-luminous (blue) flame of the Bunsen burner onto the area above the mixture where bubbles of gas are being released (see figure 12.4).

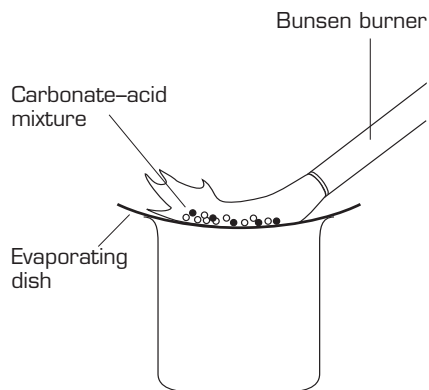


figure 12.4

### safety

- Wear gloves, safety glasses and a laboratory coat for this experiment.
- Hydrochloric acid is corrosive.
- These carbonates may cause irritation to eyes, skin and respiratory system. They may be harmful by inhalation and swallowing.
- The hydrochloric acid should have been neutralised by the metal carbonates in this experiment. Dispose of the resulting solution by flushing down the sink with plenty of water.

### Results

Record your observations in a table.

### Discussion

- 1 What gas is produced during a reaction between a carbonate and an acid?
- 2 What causes the flame colour, the anion or the cation? How can you tell?
- 3 Why does each metal only produce one distinctive flame colour?

### Questions

- 3 A student is given two beakers, each containing a clear solution. One contains sodium chloride, the other contains potassium chloride. Describe how the student could use flame testing to identify each solution.
- 4 Explain why some metals give off a distinctive colour when they are heated in a Bunsen burner flame.
- 5 Small amounts of metal compounds are added to create different colours in fireworks. What would you recommend to add to produce a green colour in the fireworks?

## 12.3 Chromatography

**Chromatography** is a technique used to separate a mixture of substances into its individual components based on their adsorption to a particular surface. It is mainly used for mixtures of organic compounds, such as pesticides in water and soil, drugs present in blood and pollutant compounds in exhaust emissions.



**Chromatography** is a procedure which separates the components of a mixture based on their adsorption to a particular surface.

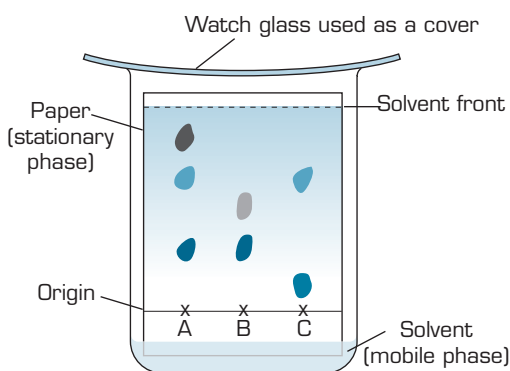




**figure 12.5** This simple chalk chromatogram shows the separation of black ink into its different components.

## Paper chromatography

The experimental set-up for a paper chromatography investigation is shown in figure 12.6. In this particular experiment there are different mixtures of food colours being analysed. These mixtures are identified as A, B and C. A dot of each food colour is put onto a piece of high quality absorbent paper similar to filter paper. The original spots are made a particular distance from the end of the paper and marked on the paper. At the conclusion of the experiment, measurements are made from this **origin**.



**figure 12.6** Paper chromatography of food colours.

The piece of paper is known as the **stationary phase** because it does not move during the experiment. The solvent at the bottom of the beaker gradually moves up the paper and is called the **mobile phase** of the experiment.

Each food colour is made up of a different mixture of components, which separate out as the mobile phase moves up through the stationary phase. The individual components **adsorb** to the stationary phase (the paper) then **desorb** back into the mobile phase (the solvent) in a continual process, gradually moving up the chromatography paper with the solvent. The rate at which each component moves is different due to their different strengths of adsorption to the stationary phase and how readily they dissolve back into the mobile phase.

From figure 12.6 we can see that food colour A is made up of three different substances and that colours B and C are made up of two colours each. Food colours B and C may also have one component each in common with colour A since they have spots in similar positions on the chromatogram. Individual components of a mixture can be assigned an  $R_f$  value derived from measurements taken of the chromatogram.

$$R_f = \frac{\text{distance moved by the component from the origin}}{\text{distance moved by the solvent from the origin}}$$

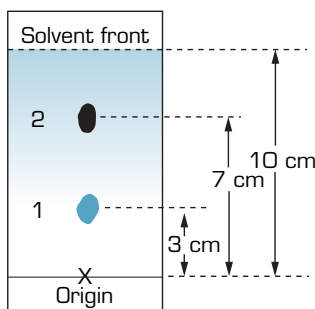
The components of the mixture adsorb to the **stationary phase** of a chromatogram.

The **mobile phase** of a chromatogram moves over the stationary phase.

**Adsorption** is the process in which atoms or molecules of one substance bond to the surface of another solid or liquid substance. **Desorption** is the reverse process.

The chromatogram of figure 12.7 shows a mixture made up of two components. The one that is closest to the origin is the one that is most strongly adsorbed onto the stationary phase and so it has moved the least. It also has a smaller  $R_f$  value than the other component.

Since the distance moved by the component is always less than the distance moved by the solvent,  $R_f$  values are always less than one. Regardless of the size of the chromatogram or the distance the solvent has moved, the  $R_f$  value of a particular substance will always be the same as long as other conditions are kept constant. Therefore  $R_f$  values can be used to identify a substance from recorded standard values.



$$R_f \text{ (component 1)} = \frac{3}{10} = 0.3$$

$$R_f \text{ (component 2)} = \frac{7}{10} = 0.7$$

**figure 12.7**  $R_f$  calculations of the components on a chromatogram.

**Worksheet 1**  
Chromatography

## Experiment 12.2

### Chromatography of Smarties and felt-tip pens

#### Introduction

The process of chromatography is used to determine the components of certain substances. Different substances will travel up the chromatography paper at different rates, causing a visible separation. This can be used to identify unknown substances using known standards.

#### Purpose

To separate the component colours from samples of felt-tip pens and Smarties.

#### Method

Felt-tip pens

- 1 Pour about 1 cm of NaCl solution into a 250 mL beaker.
- 2 Use the pencil to draw an origin line 2 cm from the narrow end of one piece of chromatography paper.
- 3 Use different coloured pens to place up to four spots on the origin line drawn in pencil.
- 4 Fold the paper over at the top end so that it hangs over the edge of the beaker. Fold enough so that the bottom of the paper just touches the solvent in the beaker.
- 5 Let the solvent rise 7–8 cm up the chromatography paper.

#### materials

- 30 mL of 1% NaCl solution
- water-soluble felt-tip pens 3–4 colours (try to include black)
- 2 Smarties (preferably brown, dark-brown–black, orange, green or violet)
- 2 × 250 mL beakers
- 2 strips of chromatography paper about 6 cm × 15 cm
- 2 small watch glasses
- pencil
- ruler
- 2 small capillary (spot) tubes



445

Qualitative and quantitative testing



12



## safety

- Do not be tempted to eat the Smarties you have used in this experiment.

- Remove the chromatography paper from the beaker.
- Immediately record the level of the solvent on the paper.

### Smarties

- Use the pencil to draw an origin line about 2 cm from the narrow end of the second strip of chromatography paper.
- Choose two Smarties.
- Place each Smartie on a separate watch glass.
- Add one or two drops of water to the Smartie to remove some of the colour. Use the capillary tubes to draw up a sample of each solution. (The more concentrated the solution, the better.)
- Spot a sample of dye from each Smartie onto the origin of the chromatography paper by touching it lightly and quickly onto the paper. When the first spot has dried, repeat the previous step.
- Pour about 1 cm of NaCl solution into a 250 mL beaker.
- Repeat steps 4–7 of the felt-tip pen procedure.

### Results

Draw and label the resulting chromatograms for the felt-tip pens and Smarties.

### Discussion

- Calculate the  $R_f$  value for each substance tested.
- Explain why the colours separate as they travel up the chromatography paper.
- Which colour(s) appeared to give the best results?
- Explain why a pencil is used to mark the origin line rather than a pen.
- Explain why the sample spots need to be above the level of the solvent at the start.

### Disposal

The Smarties should be placed into the appropriate rubbish container. The solutions from the beakers should be flushed down the sink with water.

## Experiment 12.3

### Chromatography of a vegetable extract

### Introduction

An organic solvent which is less polar than water is used in this experiment. Some plant pigments are more polar than others. The more polar pigments will have a greater attraction to the chromatography paper and move slowly. The less polar pigments will have less attraction for the paper and be more soluble in the organic solvent. This means that they will move more rapidly up the chromatography paper. A combination of these factors should cause the separation of the pigments in the sample.

### Purpose

To separate the pigments from a vegetable leaf using paper chromatography.

## Method

- 1 Prepare the vegetable sample by grinding the chopped leaf with the 10 mL of acetone and about half a spatula of fine sand using the mortar and pestle.
- 2 Draw a line in pencil 2 cm from one end of the chromatography paper.
- 3 Use the capillary tube to draw up some of the vegetable–acetone solution.
- 4 Use the capillary tube to draw a very thin line over the top of your pencil line on the chromatography paper.
- 5 Let the line of sample dry on the chromatography paper.
- 6 Repeat steps 4 and 5 until a thin, deep green line has been formed.
- 7 Straighten out the paperclip. Put it through the end of the chromatography paper opposite to that of the sample.
- 8 Pour the petroleum ether–acetone mixture into the 250 mL beaker to a depth of about 1 cm.
- 9 Use the paperclip to hang the chromatography paper in the 250 mL beaker so that the bottom of the paper just touches the petroleum ether–acetone mixture.
- 10 Place the 600 mL beaker upside down over the top of the 250 mL beaker.
- 11 When the solvent has risen about 7 cm up the paper, remove the paper from the beaker. Use the pencil to immediately mark the level that the solvent reached.

## Results

Draw and label a diagram of the resulting chromatogram.

## Discussion

- 1 Calculate the  $R_f$  value for each component on the chromatogram.
- 2 How many different components did the sample appear to contain?
- 3 Propose an explanation for the need to keep the sample line as narrow as possible.

## Disposal

Throw the plant material and chromatography paper in the appropriate rubbish container. Immediately dispose of the solvent as directed by your teacher.

## materials

- 250 mL beaker
- 600 mL beaker
- mortar and pestle
- strip of chromatography paper 2 cm × 10 cm
- finely chopped portion of vegetable leaf (spinach or silver beet)
- small amount of fine sand
- 25 mL of 9 : 1 mixture of petroleum ether and acetone
- 10 mL of acetone
- paperclip
- spatula
- glass capillary tube
- pencil
- ruler

## safety

- Wear safety glasses and a laboratory coat for this experiment.
- Petroleum ether and acetone are flammable. Do not use them near flames.
- Avoid breathing the vapours of petroleum ether and acetone. They may cause irritation to the eyes and nose.

## Questions

- 6 Figure 12.5 shows a simple chromatogram using a piece of chalk. In this system, name the
  - a stationary phase
  - b mobile phase.
- 7 Explain why the  $R_f$  value is always less than one.
- 8 In any chromatography, the solvent level needs to be lower than the origin. Explain why this is necessary.
- 9 A sample of a substance is spotted onto a piece of chromatography paper at the origin. It separates into two components, A and B. Component A moves 4.6 cm from the origin. Component B moves 6.2 cm from the origin. Calculate the  $R_f$  value for each component if the solvent front has moved 8.0 cm from the origin.



## 12.4 Qualitative analysis using physical and chemical properties

Chemical and physical properties are the characteristics by which one type of substance can be distinguished from or compared to another substance. Flame tests used to identify metals are based on an electron's ability to absorb and emit energy. Chromatography identifies substances based on their properties of adsorption and desorption. In some cases, more commonly known physical or chemical properties can be used to identify substances.

### Physical properties

Physical properties are those which a substance can show without losing its identity. Some commonly observed physical properties include:

- colour
- odour
- thermal (heat) conductivity
- electrical conductivity
- state of matter (solid, liquid or gas)
- hardness
- density
- malleability (able to be worked or hammered without breaking)
- ductility (able to be drawn into a wire)
- melting point
- boiling point
- taste
- elasticity.

To identify a particular substance, more than one property may need to be examined. For example, samples of two different metals may be very similar in colour. Both will conduct heat and electricity well. Both are malleable and ductile. Other properties such as density or melting point may need to be used to distinguish them. When the physical properties are identified, they can be compared with known standards and used to identify the substance.

Density is a property which is relatively easy to determine and can be used to identify a substance, particularly certain metals.

**table 12.2** The densities of some common substances.

Substance	Density ( $\text{g cm}^{-3}$ )	Substance	Density ( $\text{g cm}^{-3}$ )
aluminium	2.70	lead	11.34
copper	8.92	magnesium	1.74
ethanol	0.79	tin	7.31
iron	7.86	water	1.00





## Worked example 12.4A

A cube of metal has a side length of 2.00 cm. The mass of the cube is found to be 58.5 g. Using table 12.2, what is the substance most likely to be?

The density of a substance is equal to its mass divided by its volume (at a given temperature and pressure). The volume of the cube is equal to the side measurement cubed.

$$V = (\text{side length})^3$$

$$V = 2.00^3$$

$$V = 8.00 \text{ cm}^3$$

$$\text{density} = \frac{\text{mass}}{\text{volume}}$$

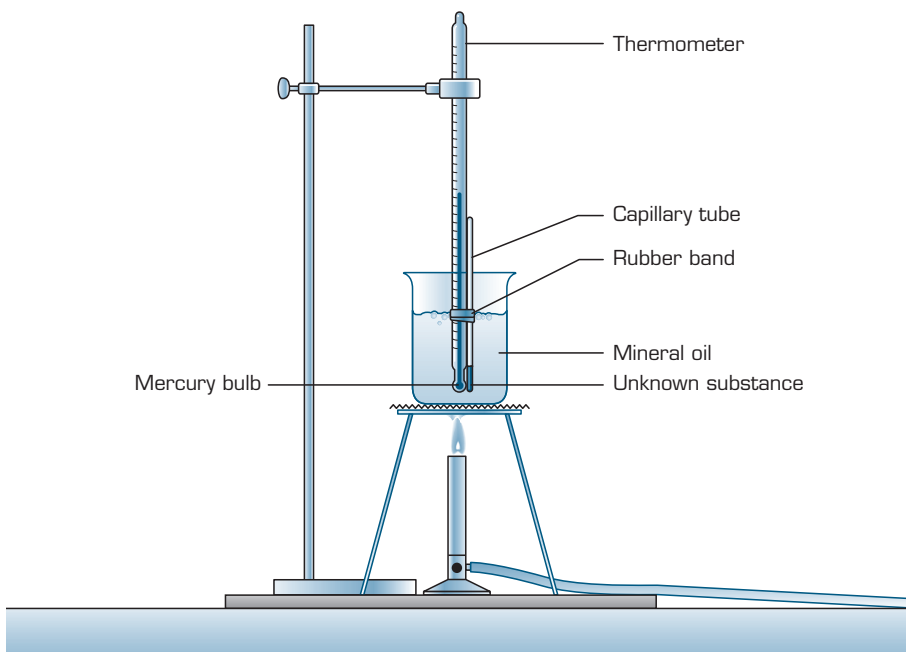
$$= \frac{58.5}{8.00}$$

$$= 7.31 \text{ g cm}^{-3}$$

Comparing this to the table of known densities, the substance is probably tin. To be sure, other properties such as melting point could be compared to known standards.

Melting points are commonly used to identify organic substances. Many organic solids melt at temperatures below 200°C, making it practical to measure. The melting point of a pure substance can be compared to known standards to identify the substance. Due to the flammability and toxicity of many of these compounds, specialised techniques which require only a small amount of sample are often used.

A simple procedure often used in university and analytical laboratories involves using capillary tubes such as those used in the chromatography experiments earlier in the chapter. One end of the capillary tube is sealed by holding it over the Bunsen burner. The open end of the tube is then placed into a pile of the sample to be tested (which has been ground into a powder). The



**figure 12.8** This set-up allows the safe determination of the melting point for some substances.



Many metals have very high melting points. Using melting points to distinguish metals in a school laboratory is not practical.



Some substances do not melt. For example, wood will decompose into different substances rather than changes phase.



tube is then tipped upside down and gently tapped to move the sample to the closed end of the tube. This is then placed into a special melting device or an apparatus such as shown in figure 12.8. The melting point is often recorded as a range from the temperature at which the substance starts to liquefy to the temperature at which the last of the solid is melted.

Most pure substances have a range of 2°C or less in their melting temperature. If a sample has impurities, its melting point will differ from that of the pure substance and the range may be greater than that of the pure substance.

**table 12.3** The melting points of some organic substances.

Compound	Melting point (°C)	Compound	Melting point (°C)
benzophenone	49–51	benzoin	137
vanillin	80–81	cholesterol	149–150
naphthalene	80–82	adipic acid	152–153
1-naphthol	95–96	citric acid	153–155
2-naphthol	121–122	salicylic acid	158.5–159
benzoic acid	121.5–122	succinic acid	184.5–185
cinnamic acid	132.5–133		

### Worked example 12.4B

Two organic substances are loaded into capillary tubes and their melting point determined. Substance A melts at 154°C. Substance B melts at 81°C. What is the likely identity for each of these substances?

Substance A: From table 12.3, the only substance which has a temperature of 154°C in its range is citric acid (153–155°C). The substance is most likely citric acid.

Substance B: From table 12.3, the substance could be vanillin (80–81°C) or naphthalene (80–82°C). Further examination of properties may be needed to make a choice between the two substances.

## Chemical properties

Chemical properties are displayed in chemical reactions. This means that the original substance loses its identity, as it is changed by the chemical reaction. It is not as easy to label chemical properties as it is physical properties. Chemical properties are tied to the chemical changes which occur. This makes it difficult to label a set of properties such as those listed for physical properties.

Some chemical properties include:

- reactivity with water
- reactivity with acids
- reactivity with bases
- combustibility (reaction with oxygen; giving off heat energy)
- rusting (slow reaction with oxygen to form rust)
- pH (concentration of hydrogen ions in solution).

No two substances have exactly the same physical and chemical properties under the same conditions. This allows us to distinguish between different substances. For example, if a substance is described only as a clear, colourless

liquid, there are a large number of substances it could be. However, water is the only clear, colourless substance that has a boiling point of 100°C and freezes at 0°C at 1 atm pressure, and which dissolves relatively large amounts of sodium chloride and reacts violently with sodium metal to produce hydrogen gas. A combination of physical and chemical properties can be used to determine the nature of an unknown substance.

## Worksheet 2

Qualitative and quantitative testing

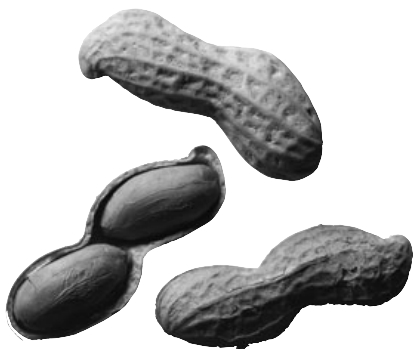
### Questions

- 10 A lump of metal has an irregular shape so its volume is calculated by the displacement method. When placed in a measuring cylinder of water, the level of the water rises by 5.50 mL. The mass of the sample is found to be 43.0 g.
- Use table 12.2 to identify the sample.
  - Describe some other properties which could be used to be more certain of the sample's identity.
- 11 A student is given two small cubes of metal which are exactly the same size and very similar in appearance. Describe how the student could try to identify the samples using simple laboratory methods.
- 12 A chemist has two clear, colourless liquids, one of which is water. Describe how the chemist could determine which liquid is the water based on simple physical properties.
- 13 The experimental melting point of an unknown organic solid is shown to be 121.5°C. Use table 12.3 to determine which substance(s) the unknown could be.

## 12.5 Quantitative analysis

Determining the amount of chemicals in a substance has become increasingly important, particularly in the quality control of foods, water and drugs that we consume. Maximum levels have been set for chemicals which can be harmful to human health and the environment. Quantitative analysis is used to monitor the levels of such chemicals. This allows us to make assessments such as whether a substance is safe for human consumption or if a substance is harmful to the environment.

For example, a particular mould that grows on peanut plants produces substances called aflatoxins. These substances are among the strongest carcinogens known. It is believed that high levels of these substances are very harmful, in particular causing cancer of the liver. The National Health and Medical Research Council have set a maximum level of 15  $\mu\text{g kg}^{-1}$  of aflatoxins in peanuts and their associated products. Quantitative testing is essential to check that peanuts and peanut products comply with these levels to keep human exposure to the aflatoxins as low as possible.



**figure 12.9** Quantitative analysis monitors toxin levels in peanuts and many other foods intended for human consumption.

Quantitative analysis is carried out to determine numerical information such as mass or concentration of components of a chemical substance.

Carcinogens are substances which cause cancer.

12



451

Qualitative and quantitative testing



In many areas of quality control, quantitative analysis must be an ongoing process. For example, the quality of our drinking water must be constantly watched. The amount of fluoride in water is carefully monitored. The Australian Drinking Water Guidelines set the safe health level for fluoride as  $1.5 \text{ mg L}^{-1}$ . Many cities add fluoride to their water supply (up to  $1 \text{ mg L}^{-1}$ ) as it is believed to protect teeth against decay. However, levels of over  $1.5 \text{ mg L}^{-1}$  are considered unsafe as it can lead to dental fluorosis (discoloration or staining of teeth) which can also affect the strength of teeth.

Quantitative labelling of products, especially food, allows us to make more informed decisions when buying and consuming processed and packaged foods. The label in figure 12.10 shows both qualitative and quantitative information.

**INGREDIENTS:**

Glucose Syrup From Wheat, Sugar, Gelatine, Water, Dextrose, Maize Starch, Wheat Starch, Flavour, Colours (102,122,110,133), Mineral Salt (452).

May contain traces of nuts.  
May contain traces of propolis.  
Contains sulfites.

NUTRITION INFORMATION:		
SERVINGS PER PACKAGE: 5		
SERVING SIZE: 20 g		
	Avg. Quantity Per Serving	Avg. Quantity Per 100 g
ENERGY	272 kJ	1360 kJ
PROTEIN	LESS THAN 1 g	3.4 g
FAT, total	LESS THAN 1 g	LESS THAN 1 g
— saturated	LESS THAN 1 g	LESS THAN 1 g
CARBOHYDRATE	15.9 g	79.5 g
— sugars	11.1 g	55.3 g
SODIUM	21 mg	104 mg

**figure 12.10** This label from a marshmallow packet provides qualitative and quantitative information to the consumer.

Knowing the contents of a product can help consumers avoid foods that may be harmful to them. A consumer with a severe peanut allergy would know to avoid the product in figure 12.10 due to the qualitative information on the label.

Chemical analysis is also important in the development and production of new substances such as pharmaceuticals and materials for manufacturing the many products we consider essential in our everyday lives.

Questions

- 14 'The breathalyser test given to motorists is a type of quantitative analysis.' Explain whether or not you agree with this statement.
- 15 Describe an example of how quantitative analysis could be useful in the following situations.
  - a a major sporting competition such as the Olympic games
  - b a water treatment plant
  - c a forensic laboratory
- 16 Drinking water is tested for levels of many substances. Tests for pesticide levels are routinely carried out. Propose an explanation for how pesticides would enter the water system.
- 17 A 2.5 L sample of drinking water was found to contain 3.6 mg of fluoride. Does this sample comply with the recommended guidelines?
- 18 A normal, healthy adult requires only about 2 g of sodium per day to maintain proper body function. Some surveys suggest that the average Australian consumes much more than this—about 11 g. As many foods contain some sodium (even cow's milk) it is easy to reach the 2 g needed per day. If a person consumed one serving of marshmallows described by the label in figure 12.10, what percentage of their basic sodium requirement would they have consumed?
- 19 Besides food allergies, what are some reasons the qualitative and quantitative information on food labels may be useful?



## Summary ▶▶▶▶

- ▶ The types of chemicals which a substance is composed of can be determined by **qualitative analysis**. **Quantitative analysis** is used to determine the amount of a particular chemical in a substance.
- ▶ **Flame tests** can be used to identify the presence of some metals due to the colour produced as excited electrons release energy and return from an **excited state** back to a lower energy level.
- ▶ **Paper chromatography** is a simple method for separating mixtures of substances into their components. **Chromatography** always involves a **stationary phase** and a **mobile phase**. The mobile phase moves through the stationary phase taking with it the components of the mixture. Individual components **adsorb** onto the stationary phase and **desorb** into the mobile phase at different rates, causing these components to separate out.
- ▶ The distance the component moves from the **origin** can be used to calculate an  **$R_f$  value** for that component. Standard  $R_f$  values can be used to identify unknown components.
- ▶ Each substance has a unique set of physical and chemical properties. The properties of an unknown substance can be compared to known standards to identify the substance.
- ▶ Quantitative testing is used to monitor levels of many substances which can be harmful to health and the environment. Qualitative and quantitative labelling of products allow consumers to make more informed choices.

## Key terms ▶▶

adsorb  
chromatography  
desorb

excited state  
flame test  
mobile phase

origin  
paper chromatography  
qualitative analysis

quantitative analysis  
 $R_f$  value  
stationary phase

## Chapter Review

### 12.1 Testing a sample

- 20 For each of the following cases, explain whether it is an example of quantitative or qualitative analysis.
- A sample of fries seasoning contains salt, chicken extract, rice flour, paprika and chilli.
  - Dry air contains 78% nitrogen (v/v).
  - A sample of ore contains iron and oxygen.
  - A chocolate biscuit contains 2.3 g protein, 6.6 g fat and 24.4 g carbohydrate per 100 g serve.
- 21 Table 12.4 shows an extract from the table of nutritional information printed on the back of a 230 g packet of corn chips.

table 12.4

Nutrient	Per 100 g serve
energy	2160 kJ
protein	9.0 g
fat—total	27.1 g
carbohydrate—total	59.1 g
cholesterol	6.6 mg
dietary fibre	3.5 g
sodium	570 mg
potassium	202 mg

- Most packaged foods must show some qualitative and quantitative information on their labelling. Discuss some reasons for why this information may be useful to consumers.
  - A patient with high blood pressure is advised by the doctor to carefully monitor his sodium intake. How much sodium will he consume in a 50 g serve of the corn chips?
  - A heart patient has to monitor his daily fat intake. He has only 6.5 g remaining in his daily fat allowance. How many grams of corn chips could he eat?
- 22 In recent years, concerns have been raised over the level of mercury in fish. Quantitative analysis has determined the safe level for mercury intake as 1.6  $\mu\text{g}$  per kg body weight per week. Large fish at the top of the food chain (e.g. swordfish, flake and barramundi) generally contain higher levels of mercury than canned or other fish. Table 12.5 shows the average mercury level determined for three categories of fish.
- How many 150 g portions of barramundi could a 72.0 kg man safely consume in one week?

table 12.5

Type of fish	Mercury level ( $\mu\text{g}$ Hg per kg fish)
barramundi	280
salmon	10
other fish	90

### 12.2 The flame test

- 23 Flame tests in the laboratory are often conducted using a wire loop with a heat-resistant handle. The wire loop is dipped into the sample to be tested and then placed into the Bunsen flame.
- Why would it be unsuitable to use wires made of copper to test the sample in the flame?
  - Students are instructed to heat their wire in the hottest part of the flame for a few minutes before using it to test their sample. Propose an explanation for this.
  - The sample tested burns with a pale yellow-green flame. What metal is the sample most likely to contain?
- 24 A student has found some unlabelled plastic storage containers. The student is not sure if they contain potassium nitrate, strontium nitrate or a mixture of both. Describe a simple method that could be used to correctly re-label the containers.

### 12.3 Chromatography

- 25 Explain the difference between the terms adsorption and desorption.
- 26 A sample of brown dye from a lolly is placed at the origin on a strip of chromatography paper. The solvent front moves 9.0 cm from the origin. A blue component of the dye moves 7.5 cm and a red component 5.2 cm in the same time. Calculate the  $R_f$  values of the two components.
- 27 Using paper chromatography, the black dye used in a brand of writing ink was found to contain blue, red, orange and yellow components. The  $R_f$  values of these substances using ethanol as a solvent are 0.59, 0.32, 0.80 and 0.19 respectively.
- How far apart would the blue and yellow components be after the solvent front had moved 8.0 cm from the origin?
  - When the red component had travelled 6.0 cm from the origin, how far would the orange component have travelled?
  - Sketch the chromatogram of the ink to scale after the solvent front has moved 15 cm from the origin.

## 12.4 Qualitative analysis using physical and chemical properties

- 28** A lump of metal with a mass of 4.0 g is placed into a measuring cylinder of water. The level of the water rises from 10.0 mL to 12.3 mL. Use table 12.2 to suggest the identity of the lump of metal.
- 29** A metallic cube has a side measurement of 25.0 mm. A student uses an electronic balance to determine its mass, which is found to be 174.5 g.
- Using table 12.2, determine which metal the sample is most likely to be.
  - Propose reasons that the experimental value is not exactly the same as the accepted value from the table.
- 30** Students have produced an organic compound during a chemistry experiment. They have been asked to identify the compound based on melting temperature. The results of their experimental melting temperatures are shown in table 12.6.

table 12.6

Group number	Melting temperature range (°C)
1	150–153
2	152–156
3	154–156
4	155–158

- Based on table 12.6, name the compound produced in this experiment.
  - Which group's results were closest to that of the accepted value for the substance nominated in part a? Explain why.
  - Suggest reasons for the variation in the experimental results of the four groups.
- 31** A student has two bottles without labels containing identical-looking samples—one bottle contains water and the other moderately weak hydrochloric acid. Explain how the student could identify each substance using chemical and physical properties that could be observed in a classroom laboratory.

## 12.5 Quantitative analysis

- 32** The Food Standards Code requires that a certain number of sample units per lot must be tested for the analysis of mercury levels in crustacea, molluscs and packaged crustacea and molluscs.
- The prescribed sampling method states that the samples from the lots should be randomly selected. Propose an explanation for this.

table 12.7

Lots (tonnes)	Number of sample units or packages
up to 1	10
over 1 up to 5	15
over 5 up to 30	20
over 30 up to 100	25
over 100	30

- From the table 12.7, a one tonne lot requires 10 samples. If this ratio were used for a sample of 100 tonnes how many samples would be required?
    - Why do you think this ratio would not be used?
  - The recommended maximum level for mercury in crustacea and molluscs is  $0.5 \text{ mg kg}^{-1}$ . A 620 g sample of crayfish is found to contain  $2.95 \times 10^{-4} \text{ g}$  of mercury. Does it comply with the recommended maximum level?
- 33** The Food Standards Code states requirements for the labelling of foods. For juice blends, it states that the label on the packaging must list:
- the names of each juice present in the blend
  - the percentage by volume of each juice in the blend.
- Are juice manufacturers required to provide quantitative or qualitative information on the labels of their products?
  - Suggest reasons why this information may be useful to consumers.
- 34** Arsenic is a toxic substance which is found alone and in several ores in the environment. The maximum allowable level of arsenic in packaged water is  $0.05 \text{ mg L}^{-1}$ . A 375 mL bottle of spring water is tested and found to have  $1.65 \times 10^{-5} \text{ g}$  of arsenic. Does it comply with the maximum allowable amount of arsenic?
- 35** The label of a 375 g jar of crunchy peanut butter states that it is composed of 88% fresh roasted peanuts. It also states that its fat content is 51.0 g per 100 g.
- What mass of peanuts does the jar contain?
  - One serve of the peanut butter is considered to be 20 g (about one tablespoon). How many grams of fat would there be in
    - one serve?
    - the whole jar?
  - What would be the maximum mass of aflatoxin that could be found in the peanuts that were used to make this jar of peanut butter (for it to comply with set standards)?
  - How may information such as serving size and fat content be useful to the consumer?



# Volumetric and gravimetric analysis

# 13

## 13.1 Gravimetric analysis

Gravimetric analysis involves experimental analysis based on the measurement of mass. The mass can then be used to determine the identity of a substance, its composition and its formula.

### Precipitation reactions

Precipitation reactions are commonly used in gravimetric analysis, particularly for ionic compounds. A substance in an aqueous solution is reacted with another substance to form a precipitate. Often this is performed to identify the original substance (the anion or cation). The basic steps involved are shown in figure 13.1.

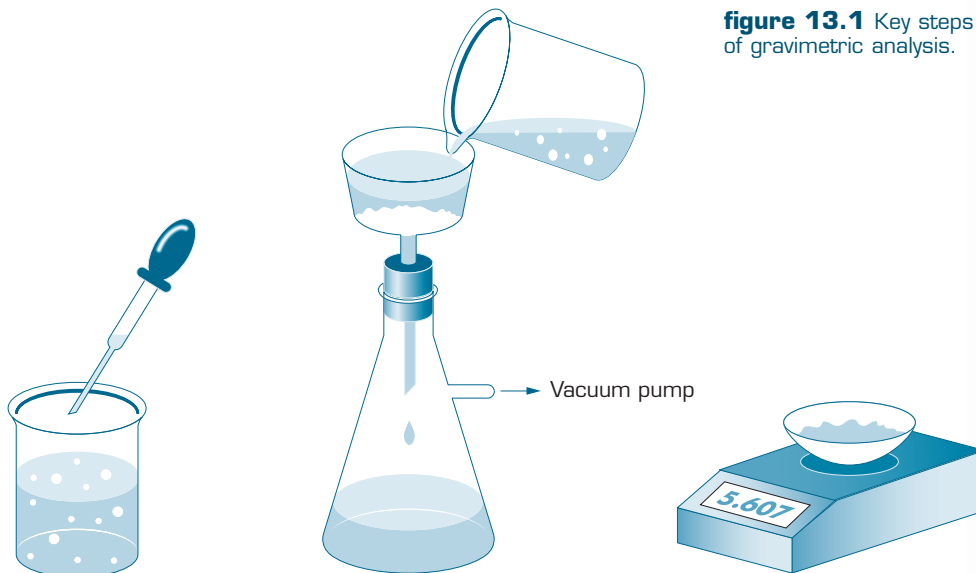
From the mass of the product and the original sample, its percent composition and identity can be determined. Table 13.1 shows precipitates that are formed for gravimetric analysis of certain elements.

**table 13.1** Precipitates formed for gravimetric analysis.

Element to be analysed	Precipitate
barium	$\text{BaSO}_4$
bromine	$\text{AgBr}$
chlorine	$\text{AgCl}$
iodine	$\text{AgI}$
iron	$\text{Fe}_2\text{O}_3$
lead	$\text{PbI}_2$
magnesium	$\text{Mg}_2\text{P}_2\text{O}_7$
phosphorus	$\text{Mg}_2\text{P}_2\text{O}_7$
sulfur	$\text{BaSO}_4$

Experimental analysis that measures mass is called gravimetric analysis.





**figure 13.1** Key steps of gravimetric analysis.

1 A precipitate of known composition is formed by a chemical reaction. The product must completely precipitate, that is, the reaction must go to completion.

2 The precipitate is isolated by filtration.

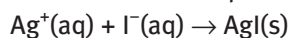
3 The precipitate is washed and dried, then its mass recorded. The precipitate must remain stable when heated.



## Worked example 13.1A

The iodide ions in a solution containing 0.300 g of sodium iodide were precipitated as silver iodide. What mass of silver iodide could be formed?

Write a balanced equation.



Calculate amount of NaI.

$$\begin{aligned} n(\text{NaI}) &= \frac{0.300 \text{ g}}{150.0 \text{ g mol}^{-1}} \\ &= 0.002 \text{ 00 mol} \end{aligned}$$

From the equation, 1 mol AgI is produced by 1 mol NaI.

$$\begin{aligned} n(\text{NaI}) &= n(\text{AgI}) \\ n(\text{AgI}) &= 0.002 \text{ 00 mol} \end{aligned}$$

Calculate the mass of AgI produced.

$$\begin{aligned} m(\text{AgI}) &= 0.002 \text{ 00 mol} \times 235.0 \text{ g mol}^{-1} \\ &= 0.470 \text{ g} \end{aligned}$$



**figure 13.2** An electronic balance is used to measure the mass of substances in gravimetric analysis.



## Percent composition of compounds and mixtures

Gravimetric analysis is useful in determining the **percent composition** of a compound or a mixture.

One of the initial steps in finding the composition of a compound is to determine the percent by mass of each of the elements present in the compound. The percent composition of each element can be calculated by using the formula:

$$\% \text{ mass} = \frac{\text{mass element}}{\text{mass compound}} \times 100\%$$

The mass of each component compared to the total mass of the compound or mixture is called **percent composition**.



### Worked example 13.1B

3.52 g of magnesium was burned in the presence of oxygen. The resulting magnesium oxide had a mass of 5.87 g. What is the percent composition of magnesium in magnesium oxide? What is the percent composition of oxygen in magnesium oxide?

$$\begin{aligned} m(\text{O}) &= m(\text{MgO}) - m(\text{Mg}) \\ &= 5.87 \text{ g} - 3.52 \text{ g} \\ &= 2.35 \text{ g} \end{aligned}$$

$$\% \text{ mass} = \frac{\text{mass element}}{\text{mass compound}} \times 100\%$$

$$\% \text{ Mg} = \frac{3.52 \text{ g}}{5.87 \text{ g}} \times 100\% = 60.0\%$$

$$\% \text{ O} = \frac{2.35 \text{ g}}{5.87 \text{ g}} \times 100\% = 40.0\%$$

To check you are correct, it is a good idea to add up the percentages to make sure they add up to 100%.

$$\text{Check: } \% \text{ Mg} + \% \text{ O} = 60.0\% + 40.0\% = 100\%$$

It is also possible to determine the percent by mass of a component in a mixture. The percent composition of a component can be calculated by using the formula:

$$\% \text{ mass} = \frac{\text{mass component}}{\text{mass mixture}} \times 100\%$$



### Worked example 13.1C

A student was given a salt, sand and iron filings mixture to separate. The 42.5 g sample contained 9.60 g of salt and 14.2 g of sand, with iron filings making up the remaining mass. Calculate the percent composition of each component of the mixture.

$$m(\text{iron}) = 42.5 \text{ g} - (9.60 \text{ g} + 14.2 \text{ g}) = 18.7 \text{ g}$$

$$\% \text{ mass} = \frac{\text{mass component}}{\text{mass mixture}} \times 100\%$$

$$\% \text{ salt} = \frac{9.6 \text{ g}}{42.5 \text{ g}} \times 100\% = 22.6\%$$

$$\% \text{ sand} = \frac{14.2 \text{ g}}{42.5 \text{ g}} \times 100\% = 33.4\%$$

$$\% \text{ iron} = \frac{18.7 \text{ g}}{42.5 \text{ g}} \times 100\% = 44.0\%$$

Check: % salt + % sand + % iron = 22.6% + 33.4% + 44.0% = 100%

## Experiment 13.1

### Percent composition of a compound

#### Purpose

To find the percentage by mass of magnesium in magnesium oxide.

#### Method

- 1 Your teacher will give you a 20–40 cm length of magnesium ribbon. Clean the magnesium thoroughly using steel wool.
- 2 Find the mass of a clean, dry crucible and lid. Coil the magnesium loosely and place it in the crucible. Find the total mass of crucible, lid and magnesium.
- 3 Heat the crucible strongly. Using tongs, occasionally lift the lid to allow air to enter the crucible but replace it quickly to avoid loss of magnesium oxide ash.
- 4 When the reaction appears complete, allow to cool to room temperature and find the total mass of crucible, lid and magnesium oxide.
- 5 Calculate the original mass of magnesium used and the mass of magnesium oxide formed.
- 6 Assuming that all the original magnesium metal is now in the form of magnesium oxide, calculate the percentage of magnesium in magnesium oxide. Round off your result to the nearest 1%.

#### Discussion

- 1 Compare your result with those obtained by groups of students who had different starting masses of magnesium. Are the results the same or different? Would you expect them to be the same or different? Why?
- 2 There are many sources of error associated with this experiment. List some of the major ones.
- 3 The formula for magnesium oxide is MgO. This means that one magnesium ion ( $\text{Mg}^{2+}$ ) is present for every oxygen ion ( $\text{O}^{2-}$ ) in this compound. From your experimental result, deduce which of these two ions has the greater mass.
- 4 The percentage by mass of aluminium in alumina (aluminium oxide) is 52.9%. What mass of aluminium could theoretically be extracted from 800 tonnes of alumina?

#### materials

- magnesium ribbon between 20 cm and 40 cm long
- steel wool
- crucible and lid
- pipeclay triangle
- Bunsen burner
- bench mat
- tripod
- tongs
- electronic balance

#### safety

- Wear safety glasses and a laboratory coat for this experiment.
- Do not look directly at the magnesium during heating. It may damage your sight.
- Take care if handling a hot crucible.



## Questions

- Describe the properties of a precipitate used in gravimetric analysis that you would consider important.
- A solution containing 10.0 g of silver nitrate is mixed with a solution containing 10.0 g of barium chloride.  
 $2\text{AgNO}_3(\text{aq}) + \text{BaCl}_2(\text{aq}) \rightarrow 2\text{AgCl}(\text{s}) + \text{Ba}(\text{NO}_3)_2(\text{aq})$   
What mass of silver chloride precipitate could be produced?
- Calculate the percentage by mass of:
  - iron in iron(III) oxide ( $\text{Fe}_2\text{O}_3$ )
  - uranium in uranium oxide ( $\text{U}_3\text{O}_8$ )
  - nitrogen in ammonium chloride ( $\text{NH}_4\text{Cl}$ )
  - oxygen in copper nitrate ( $\text{Cu}(\text{NO}_3)_2$ ).
- Determine the percent composition of each element in the following compounds.
  - naphthalene,  $\text{C}_{10}\text{H}_8$
  - acetic acid,  $\text{CH}_3\text{COOH}$
  - aluminium nitrate,  $\text{Al}(\text{NO}_3)_3$
  - urea,  $\text{NH}_2\text{CONH}_2$
  - perchloric acid,  $\text{HClO}_4$
  - aspirin,  $\text{C}_6\text{H}_4(\text{OCOCH}_3)\text{COOH}$

## 13.2 Empirical and molecular formulae

Analysis of the mass of each element present in a compound allows for the identification of a compound experimentally. The analysis shows the simplest whole-number ratio of elements present in the compound, called the **empirical formula**. The empirical formula however does not show the actual number of each type of atom present.



### Worked example 13.2A

Burning 2.34 g of magnesium in air produced 3.90 g of magnesium oxide. Determine the empirical formula of the oxide of magnesium.

First of all, the mass of each element must be known.

$$\begin{aligned}m(\text{O}) &= m(\text{Mg}_x\text{O}_y) - m(\text{Mg}) \\ &= 3.90 \text{ g} - 2.34 \text{ g} \\ &= 1.56 \text{ g}\end{aligned}$$

Write the ratio by mass.

Mg : O

$$2.34 \text{ g} : 1.56 \text{ g}$$

Determine the mole ratio of the elements.

$$\begin{aligned}& \frac{n(\text{Mg})}{m(\text{Mg})} : \frac{n(\text{O})}{m(\text{O})} \\ &= \frac{m(\text{Mg})}{M(\text{Mg})} : \frac{m(\text{O})}{M(\text{O})} \\ &= \frac{2.34 \text{ g}}{24.3 \text{ g mol}^{-1}} : \frac{1.56 \text{ g}}{16.0 \text{ g mol}^{-1}} \\ &= 0.0963 : 0.0975 \\ &\approx 1 : 1\end{aligned}$$

The empirical formula for this oxide of magnesium is MgO.



## Worked example 13.2B

A sample of a compound is found to contain 6.65 g of nitrogen and 19.2 g of oxygen. Determine the empirical formula.

Write the ratio by mass.

N : O

6.65 g : 19.2 g

Determine the mole ratio.

$$\begin{aligned}
 & n(\text{N}) : n(\text{O}) \\
 = & \frac{m(\text{N})}{M(\text{N})} : \frac{m(\text{O})}{M(\text{O})} \\
 = & \frac{6.65 \text{ g}}{14.0 \text{ g mol}^{-1}} : \frac{19.2 \text{ g}}{16.0 \text{ g mol}^{-1}} \\
 = & 0.475 \text{ mol} : 1.20 \text{ mol}
 \end{aligned}$$

Divide by the smaller amount.

$$\begin{aligned}
 = & \frac{0.475}{0.475} : \frac{1.20}{0.475} \\
 = & 1 : 2.53
 \end{aligned}$$

Find a multiple to give a whole number ( $\times 2$ ).

$$= 2 : 5$$

$\therefore$  The empirical formula of the compound is  $\text{N}_2\text{O}_5$ .

Once an empirical formula is determined for a compound, the next step involves developing the **molecular formula**, which shows the actual number of each type of atom present. If the molar mass and empirical formula of the compound are known, the molecular formula can be determined. The molecular formula is always a whole-number ratio of the empirical formula.

For example, hydrogen peroxide has the formula  $\text{H}_2\text{O}_2$ . This is its molecular formula, as a molecule of hydrogen peroxide is composed of two hydrogen atoms and two oxygen atoms. As an empirical formula is the simplest whole-number ratio of the elements present, the empirical formula for hydrogen peroxide is HO. Table 13.2 compares the empirical and molecular formulas of different substances.

**table 13.2** Empirical and molecular formulae of different substances.

Substance	Empirical formula	Molecular formula
dinitrogen tetroxide	$\text{NO}_2$	$\text{N}_2\text{O}_4$
ethene	$\text{CH}_2$	$\text{C}_2\text{H}_4$
ethyne	CH	$\text{C}_2\text{H}_2$
oxygen	O	$\text{O}_2$
tetraphosphorus decoxide	$\text{P}_2\text{O}_5$	$\text{P}_4\text{O}_{10}$

For some substances the empirical and molecular formulae are the same. For example, the molecular formula for ammonia is  $\text{NH}_3$ , which is also its empirical formula, as it is already in the simplest whole-number ratio. Others include water ( $\text{H}_2\text{O}$ ), methane ( $\text{CH}_4$ ) and sulfur dioxide ( $\text{SO}_2$ ).



The empirical formula of a compound shows the simplest whole-number ratio of the elements present. The **molecular formula** of a compound shows the actual number of atoms of each element present.





## Worked example 13.2C

A hydrocarbon contains 85.7% carbon. Its relative molecular mass is  $70 \text{ g mol}^{-1}$ . Determine the empirical formula and molecular formula of the hydrocarbon.

A hydrocarbon contains only carbon and hydrogen, so  
 $\% \text{ H} = 100 - 85.7 = 14.3\%$ .

Write the ratio by mass.

C : H

85.7 g : 14.3 g

Determine the mole ratio of the elements.

$$\begin{aligned} n(\text{C}) : n(\text{H}) &= \frac{m(\text{C})}{M(\text{C})} : \frac{m(\text{H})}{M(\text{H})} \\ &= \frac{85.7 \text{ g}}{12.0 \text{ g mol}^{-1}} : \frac{14.3 \text{ g}}{1.0 \text{ g mol}^{-1}} \\ &= 7.14 : 14.3 \end{aligned}$$

Divide by the smaller amount.

$$\begin{aligned} \frac{7.14}{7.14} : \frac{14.3}{7.14} \\ = 1 : 2 \end{aligned}$$

The empirical formula for this hydrocarbon is  $\text{CH}_2$ .

Molar mass of a  $\text{CH}_2$  unit (empirical formula) =  $12.0 \text{ g mol}^{-1} + 2.0 \text{ g mol}^{-1}$   
=  $14.0 \text{ g mol}^{-1}$

Molar mass of the compound (molecular formula) =  $70 \text{ g mol}^{-1}$

$\therefore$  number of  $\text{CH}_2$  units in one molecule =  $\frac{70}{14} = 5$

molecular formula =  $5 \times \text{CH}_2$

The molecular formula is  $\text{C}_5\text{H}_{10}$ .



## Experiment 13.2

### Empirical formula determination

#### materials

- 2 g copper oxide
- 3 g zinc granules
- 50 mL of 2 M  $\text{H}_2\text{SO}_4$
- 250 mL beaker
- weighing bottle
- evaporating basin
- electronic balance
- steam bath
- glass rod

#### Purpose

To determine the empirical formula of copper oxide.

#### Method

- 1 Using a weighing bottle, find the exact mass of approximately 2 g of copper oxide.
- 2 Transfer the copper oxide to a 250 mL beaker and add 50 mL of 2 M sulfuric acid. If necessary, heat the mixture by standing the 250 mL beaker in a larger beaker of hot water. Stir with a glass rod until the reaction is complete.



- 3 When all the copper oxide has reacted, add 50 mL of water and approximately 2 g of granulated zinc. Swirl and allow to react overnight. (If the solution is still blue the next day, add another 1 g of zinc and allow to stand several hours longer.)
- 4 Decant the supernatant liquid and carefully wash the deposited copper with about 50 mL of water. Wash it three more times.
- 5 Find the mass of a clean, dry evaporating basin.
- 6 Using the minimum amount of water, transfer the copper from the beaker to the evaporating basin.
- 7 Dry the copper by heating over a steam bath. When cool, find the mass of the evaporating basin plus copper.

### Discussion

- 1 Calculate the mass of copper oxide used.
- 2 Calculate the mass of copper that was in the copper oxide.
- 3 Calculate the mass of oxygen in the copper oxide.
- 4 Calculate the amount in moles of copper and oxygen in your sample of copper oxide.
- 5 Calculate the empirical formula of the compound.
- 6 How does your result compare with the accepted formulae for copper oxides? Which oxide did you use?
- 7 What are some of the major sources of error in this experiment?
- 8 Explain why the formula of magnesium oxide could not be determined by this method.
- 9 Write a balanced equation for the reaction that occurs between:
  - a sulfuric acid and copper(II) oxide
  - b zinc and the copper sulfate solution
  - c sulfuric acid and the left-over zinc. (The gas evolved in this reaction is hydrogen gas (H<sub>2</sub>).)
- 10 An empirical formula can be written for copper(II) oxide but not a molecular formula. Why not?

### safety

- Wear safety glasses and a laboratory coat for this experiment.
- Sulfuric acid is corrosive.
- Copper compounds are harmful to the eyes, lungs and skin.

## Water content

Water is not only a common component of a mixture but also forms part of the structure of many compounds. Copper(II) sulfate is a compound that is commonly used in a school laboratory and is readily recognised by its blue colour. If you heat a sample of blue copper(II) sulfate you will find that it will eventually become white in colour. The white copper(II) sulfate (CuSO<sub>4</sub>) is referred to as anhydrous as there are no water molecules attached to the crystal. The blue copper(II) sulfate (CuSO<sub>4</sub>·5H<sub>2</sub>O, copper(II) sulfate pentahydrate) is hydrated and water molecules form part of the crystal. The water is referred to as the water of crystallisation. The water is weakly attracted to the crystal and is easily driven off when heated.



An **anhydrous** substance has no water molecules attached. A hydrated substance has water attached, called **water of crystallisation**.



**Hygroscopic** substances absorb moisture from the air. A substance which can absorb enough water to form a solution is called **deliquescent**.

A hygroscopic substance that is used to absorb moisture from the air is called a **desiccant**.

Some substances, such as solid sodium hydroxide, are described as **hygroscopic** as they absorb water from the air. If sodium hydroxide is left out it will absorb enough moisture from the air to form a solution. A substance that can form a solution by absorbing water from the air is called **deliquescent**. Silica gel is another example of a hygroscopic substance that you will commonly find in the laboratory or in places where water needs to be absorbed from the air. Hygroscopic substances used to absorb moisture from the air are called **desiccants**.



**figure 13.3** Silica gel is found in little sachets in shoe boxes to absorb moisture and prevent the shoes from going mouldy. Have you ever wondered why people put rice in salt shakers?

## Worked example 13.20

Epsom salts is hydrated magnesium sulfate ( $\text{MgSO}_4 \cdot x\text{H}_2\text{O}$ ). A residue of 2.60 g of anhydrous magnesium sulfate is obtained by heating 5.32 g of Epsom salts. Determine the empirical formula of Epsom salts.

Step 1: Calculate the mass of water present in the sample.

$$\begin{aligned} m(\text{H}_2\text{O}) &= m(\text{MgSO}_4 \cdot x\text{H}_2\text{O}) - m(\text{MgSO}_4) \\ &= 5.32 \text{ g} - 2.60 \text{ g} \\ &= 2.72 \text{ g} \end{aligned}$$

Step 2: Write the ratio by mass.

$$\begin{aligned} \text{MgSO}_4 : \text{H}_2\text{O} \\ 2.60 \text{ g} : 2.72 \text{ g} \end{aligned}$$

Step 3: Calculate the ratio by amount (in moles).

$$\begin{aligned} \frac{2.60 \text{ g}}{120.3 \text{ g mol}^{-1}} : \frac{2.72 \text{ g}}{18.0 \text{ g mol}^{-1}} \\ 0.0216 \text{ mol} : 0.151 \text{ mol} \end{aligned}$$

Step 4: Divide by the smaller amount.

$$\begin{aligned} \frac{0.0216}{0.0216} : \frac{0.151}{0.0216} \\ 1 : 6.99 \end{aligned}$$

Step 5: Round off to whole numbers.

$$1 : 7$$

$\therefore$  The empirical formula of the compound is  $\text{MgSO}_4 \cdot 7\text{H}_2\text{O}$  (magnesium sulfate heptahydrate).

### Worksheet 1

Gravimetric analysis and formulae



# Experiment 13.3

## Water of crystallisation

### Purpose

To determine the empirical formula of a hydrated salt.

### Method

- 1 Label a clean, dry test tube with your initials.
- 2 Weigh the empty test tube and record its mass.
- 3 Add the hydrated salt to the test tube so that it is slightly less than half full.
- 4 Reweigh the test tube and hydrated salt. Record the mass.
- 5 Heat the salt by gently passing the test tube through a Bunsen burner flame. The salt will dissolve in its water of hydration and if heating is not done slowly and carefully the solution may boil over. Hold the test tube at an angle away from you and other people and keep it moving while in the flame. When you hear the sound of the solution beginning to boil, remove it from the flame for a few seconds and let it settle down. Note any change in colour. Keep heating gently until all of the water has evaporated. (In the case of cobalt chloride, the entire solid will become pale blue in colour. Do not overheat it or it will begin to turn black.)
- 6 Allow the test tube to cool in a desiccator for approximately 5 minutes.
- 7 Weigh the test tube and anhydrous salt and record the mass.
- 8 Heat the test tube again for several minutes, then repeat steps 6 and 7.

### Discussion

- 1 What mass of the hydrated salt was used in the experiment?
- 2 What mass of anhydrous salt remained in the test tube after heating to remove all water?
- 3 Calculate the mass of water that was present in the sample of the salt.
- 4 Determine the ratio of the amount, in mol, of water to the amount, in mol, of the anhydrous salt.
- 5 Write the chemical formula for the hydrated salt.
- 6 Hydrated cobalt chloride has been used as part of simple weather monitoring devices to indicate changes in humidity. Explain how such devices might work.

### materials

- 1.5 g of a hydrated salt: cobalt chloride or magnesium sulfate (Epsom salts)
- Pyrex test tube
- test-tube holder
- Bunsen burner
- bench mat
- electronic balance
- desiccator
- marking pen

### safety

- Wear safety glasses and a laboratory coat for this experiment.

### Questions

- 6 Determine the molecular formula of each compound in the table 13.3.

table 13.3

Empirical formula	Relative molecular mass
a CH	78
b HO	34
c CH <sub>2</sub> O	90
d NO <sub>2</sub>	46
e CH <sub>2</sub>	154

- 7 Determine the empirical formula of the compounds with the following compositions.
- a 2.74% hydrogen, 97.26% chlorine
  - b 42.9% carbon, 57.1% oxygen
  - c 10.0 g of a compound of magnesium and oxygen that contains 6.03 g of magnesium
  - d 3.2 g of a hydrocarbon that contains 2.4 g of carbon

- 8 Ethylene glycol is a compound often used as an antifreeze in cars in cold weather. Its molar mass is  $62 \text{ g mol}^{-1}$ . It has a percentage composition of 38.7% carbon, 9.7% hydrogen and the rest is oxygen. Determine both the empirical and the molecular formulae of ethylene glycol.
- 9 When 0.100 g of white phosphorus is burned in oxygen, 0.228 g of an oxide of phosphorus is produced. The molar mass of the oxide is  $284 \text{ g mol}^{-1}$ .
- Determine the empirical formula of the phosphorus oxide.
  - Determine the molecular formula of the phosphorus oxide.
- 10 What mass of barium chloride ( $\text{BaCl}_2$ ) will remain after a 15.0 g sample of the hydrated salt  $\text{BaCl}_2 \cdot 2\text{H}_2\text{O}$  is heated to drive off all of the water?
- 11 A 10 g sample of hydrated blue copper(II) sulfate is heated in a crucible over a Bunsen flame until the crystals have turned white. The mass of the white residue is found to be 6.9 g. Assume that the mass lost is due to loss of the water of hydration. On the basis of this data, determine the empirical formula of the hydrated copper(II) sulfate.
- 12 Gypsum is hydrated calcium sulfate ( $\text{CaSO}_4 \cdot x\text{H}_2\text{O}$ ). A residue of 5.65 g of anhydrous calcium sulfate is obtained by heating 7.15 g of gypsum. Determine the empirical formula of gypsum.

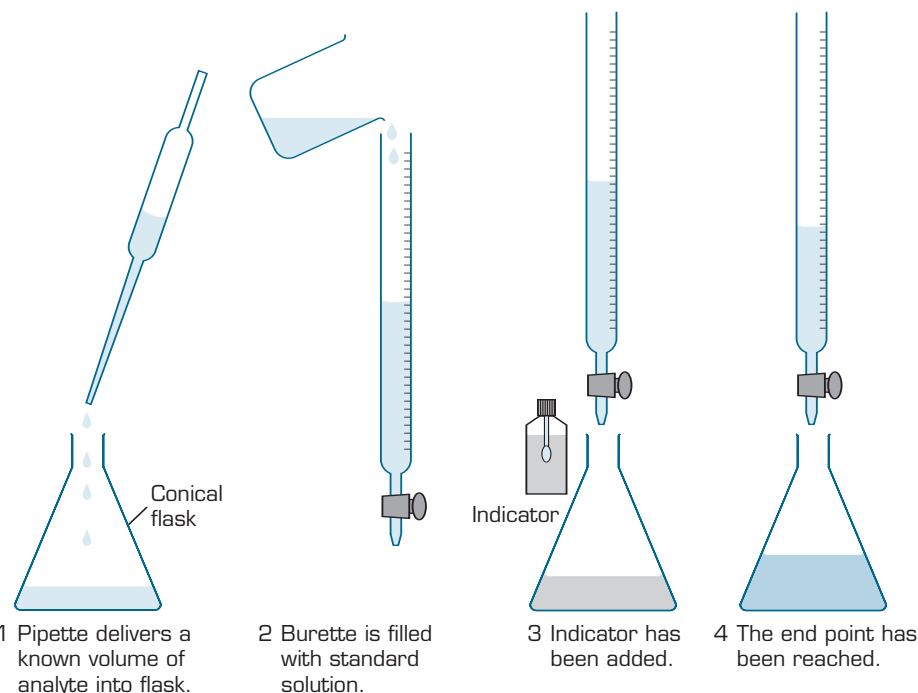
## 13.3 Volumetric analysis

**Volumetric analysis** is a form of experimental analysis that uses **titration** to determine the concentration of a solution.

### Titration

Titration is a very accurate form of analysis. The basic steps of a titration are shown in figure 13.4.

Titration is a technique used in volumetric analysis. A standard solution of known concentration is reacted against a solution of unknown concentration.



**figure 13.4** Steps involved in titration.

The first step in a titration is to measure out a known quantity of a solution of unknown concentration (the analyte). This is measured into a conical flask using a pipette. The volume added with the pipette is referred to as an aliquot. An indicator is added to this solution.

A burette is filled with a **standard solution** of accurately known concentration (the titrant) that is slowly dispensed from the burette into the conical flask. A solution has been standardised when it has been titrated against a **primary standard**. A primary standard is a substance that can be obtained in a pure form so that the number of moles can be accurately determined from its mass. For example, sodium hydroxide is commonly used as a standard solution but it is too difficult to obtain pure solid sodium hydroxide. It must first be standardised against a primary standard such as hydrated oxalic acid ( $\text{H}_2\text{C}_2\text{O}_4 \cdot 2\text{H}_2\text{O}$ ). The concentration of the titrant must be accurately known so that the concentration of the unknown can be calculated. In order to do this, the reaction between the two solutions must also be known.



The point in the titration where the titrant has reacted exactly with the analyte according to the reaction equation is called the **equivalence point**. The point where the indicator begins to change colour is called the **end point**. The end point is close to the equivalence point. Titration is complete when there is a permanent colour change. Toward the end of the titration you may need to add the titrant drop by drop, otherwise you may go past the end point.

The volume of titrant added is called the titre. This volume is used for the calculations of the concentration of the unknown solution.

**figure 13.5** Student performs a titration.



The **equivalence point** is the point in the titration where the reactants completely react, and is identified by the end point where there is a change in indicator colour.



The process of titration is the same regardless of the solutions being used. Titration is a very accurate form of analysis that does take practice.

## Experiment 13.4

### Preparation of a standard solution

#### Purpose

To prepare a standard solution from a primary standard.

#### Method

- 1 Calculate the mass of anhydrous sodium carbonate ( $\text{Na}_2\text{CO}_3$ ) required to make up 250 mL of 0.1 M solution.
- 2 Weigh out this mass of anhydrous sodium carbonate (within 0.1 g) in a weighing bottle. Record the exact mass of solid used.
- 3 Use a small funnel to transfer the sodium carbonate, a little at a time, to a 250 mL volumetric flask. Use a wash bottle of deionised water to wash traces of sodium carbonate in the weighing bottle and funnel into the flask.
- 4 Add deionised water to the flask until it is almost half full. Stopper and swirl the contents of the flask to dissolve the sodium carbonate.

#### materials

- anhydrous sodium carbonate
- 250 mL deionised water
- 250 mL volumetric flask
- weighing bottle or watch glass
- small funnel
- spatula
- dropping pipette
- wash bottle containing deionised water
- electronic balance
- paper label or marking pen



467

Volumetric and gravimetric analysis



13



## safety

- Wear safety glasses and a laboratory coat for this experiment.

- Add more water until the meniscus of the solution is nearly level with the calibration line. Use a dropping pipette to add the final few drops of deionised water so that the bottom of the meniscus is exactly level with the calibration line. (Ensure the flask is standing on a horizontal surface and your eye is at the same level as the line.)
- Shake the flask so that the concentration of the solution is uniform. Label the flask with its contents and concentration and your name.

## Discussion

- Calculate the concentration, in moles per litre (M), of the sodium carbonate solution.
- Why is solid sodium hydroxide not used as a primary standard when standard solutions of bases are required?
- Name another basic substance that is suitable for use as a primary standard.
- How would the accuracy of the standard solution be affected if the volumetric flask had been rinsed with deionised water before use and droplets of water were left in the flask when the sodium carbonate was added?
- Identify some of the sources of error associated with this experiment.

## Acid–base titrations

Titration is commonly used in reactions between an acid and a base. They can be used for example, to determine the acidity of wine or the composition of an antacid.

For the acid–base titrations you are likely to perform, the equivalence point is reached when all the  $\text{H}^+$  has reacted with all the  $\text{OH}^-$ . However, not all acid–base reactions involve  $\text{H}^+$  and  $\text{OH}^-$ .

**Indicators** used in acid–base titrations must be selectively chosen to suit the pH of the equivalence point for the acid–base reaction. Indicators are weak acids that are one colour in the acid form and another colour in the base form.

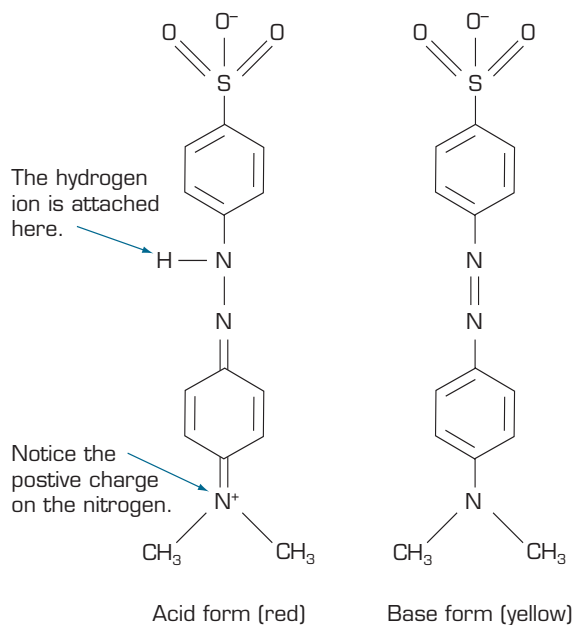
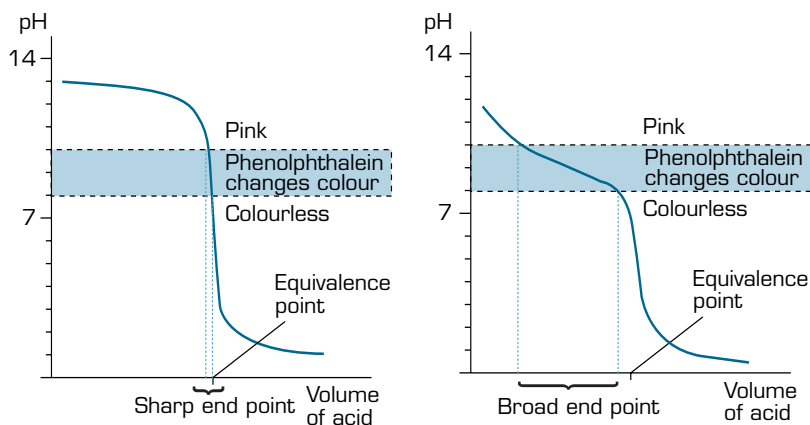


figure 13.6 The acid and base form of methyl orange indicator.

The most appropriate indicator for the particular solutions you are using can be determined using a **titration curve**. A titration curve in figure 13.7(a) shows the change in pH during a titration between a strong acid (such as HCl) and a strong base (such as NaOH). The pH range of the steepest part of the curve must match the pH range of the indicator to give a clear end point. Phenolphthalein, which changes colour in the pH range of 8.3–10.0 would be a good choice for this titration. Phenolphthalein would not be a suitable choice as an indicator between a weak base and a strong acid (figure 13.7(b)), as the steep part of the curve occurs in the pH range 3.0–5.0.



**figure 13.7** The change in colour of an indicator must occur at the pH of the steepest part of the titration curve, very close to the equivalence point, for an accurate titration.



A titration curve is a graph that shows the pH changes that occur when an acid is titrated against a base. The most appropriate indicator is selected to change colour at the equivalence point.

**table 13.4** The pH range and colour changes of various indicators.

Indicator	pH range	Acid colour	Base colour
methyl violet	0.0–1.6	yellow	blue
thymol blue (first change)	1.2–1.8	red	yellow
congo red	3.1–4.9	blue	red
methyl orange	3.2–4.4	red	yellow
litmus	5.0–7.0	red	blue
bromothymol blue	6.0–7.6	yellow	blue
phenol red	6.4–8.0	yellow	red
thymol blue (second change)	8.0–9.6	yellow	blue
phenolphthalein	8.3–10.0	colourless	dark pink
methyl blue	10.6–13.4	blue	pale violet

## Choice of indicators in acid–base titrations

In acid–base titrations, the solutions at equivalence are not necessarily **neutral**. The pH of a solution at equivalence is determined by the acidity of the salt produced.

- If an acid–base reaction produces a neutral salt then the pH of the solution at equivalence will be 7. An indicator that changes colour at this pH would be suitable for the titration.
- If a titration produces an acidic salt then the pH of the solution at equivalence

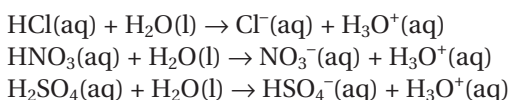


will be < 7. An indicator that changes colour in the acidic pH range would be suitable for this titration.

- Similarly, if a basic salt is produced then the pH of the solution at equivalence will be greater than 7, and an indicator that changes colour in the basic range would be most suitable.

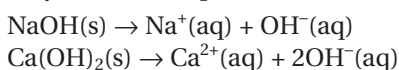
## Strong acid, strong base

Strong acids are Brønsted–Lowry acids that totally dissociate in aqueous solution. Examples of strong acids are hydrochloric acid (HCl), nitric acid (HNO<sub>3</sub>) and the first ionisation of sulfuric acid (H<sub>2</sub>SO<sub>4</sub>). Hydrolysis reactions for these acids are as follows:



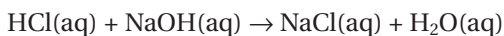
The hydrogensulfate ion is a weak acid and only partially dissociates in aqueous solution.

Strong bases include all metal oxides and hydroxides. In the pure form these compounds are solids. When added to water they **dissociate** rather than hydrolyse. For example:

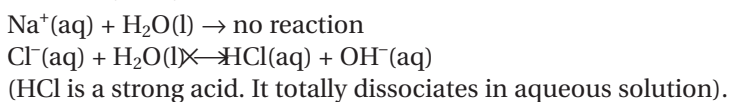


Therefore in solution (even saturated solutions) there are no molecules of these compounds present.

When a strong acid and a strong base are combined they produce a neutral salt. For example, when hydrochloric acid reacts with sodium hydroxide, the following reaction occurs:



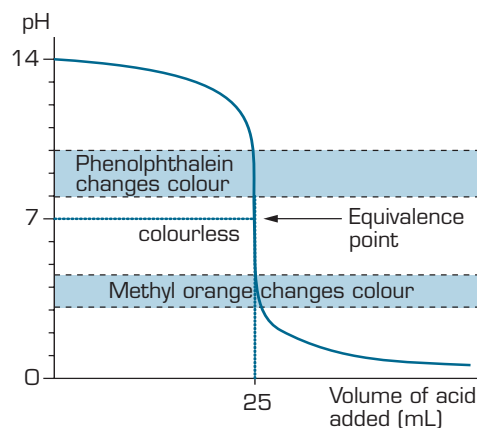
This reaction proceeds to completion and is not reversible. The ions in the salt do not hydrolyse.



At equivalence the pH of the solution is 7.

## Titration curve for strong acid vs strong base

The titration of 0.1 M HCl (titrant) against 25.00 mL of 0.1 M NaOH (analyte) is shown in figure 13.8.



**figure 13.8** Titration curve for a strong acid vs strong base.

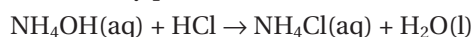
From the graph we can see that the pH only falls a very small amount until quite near the equivalence point, then there is a steep plunge. If we calculate the values, we see that the pH falls from 11.3 when 24.9 mL has been added to 2.7 when 25.1 mL has been added. Suitable indicators for this titration would include phenolphthalein (colour change pH 8.3–10.0) and methyl orange (colour change pH 3.2–4.4).

## Strong acid, weak base

In this case the weak base is also a Brønsted–Lowry base; that is, it is a molecule that accepts a proton from water, forming a hydroxide ion. An example of a Brønsted–Lowry base used in volumetric analysis is ammonia.



When a strong acid such as HCl is titrated against a weak base such as ammonia, they produce a salt and water.



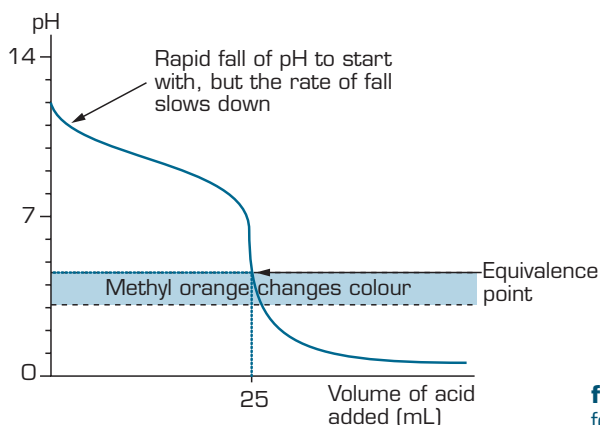
The  $\text{NH}_4\text{Cl}(\text{aq})$  is an acidic salt because the  $\text{NH}_4^+$  donates its proton to water.



This means that the pH at equivalence will be  $< 7$ .

## Titration curves for strong acid vs weak base

Titration of 0.1 M HCl (titrant) against 25.00 mL of 0.1 M ammonia solution (analyte) is shown in figure 13.9.

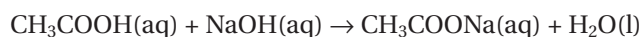


**figure 13.9** Titration curve for a strong acid vs weak base.

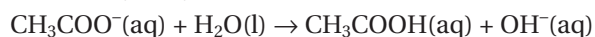
Notice that the equivalence point is now somewhat acidic (a bit less than pH 5), because ammonium chloride is acidic. However, the equivalence point still falls on the steepest part of the curve. This is important in choosing a suitable indicator for the titration. Methyl orange (colour change pH 3.2–4.4) is a suitable indicator.

## Strong base, weak acid

When a strong base is reacted with a weak acid the salt produced is basic in aqueous solution. Take ethanoic acid and sodium hydroxide as typical of a weak acid and a strong base.



The salt hydrolyses in water to produce a basic solution.



This means that the pH of the solution at equivalence will be  $> 7$ .



Titration of a strong acid against a strong base produces a neutral solution pH 7.



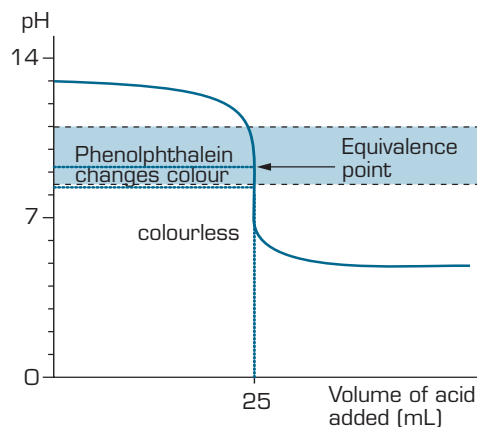
Titration of a strong acid against a weak base produces an acidic solution pH  $< 7$ .



## Titration curves for weak acid vs strong base

Titration of 0.1 M  $\text{CH}_3\text{COOH}$  (titrant) against 25.00 mL of 0.1 M  $\text{NaOH}$  solution (analyte) is shown in figure 13.10.

For the first part of the graph, there is an excess of sodium hydroxide. The curve will be exactly the same as that when hydrochloric acid was added to sodium hydroxide (figure 13.8). Once the acid is in excess, there is a difference.

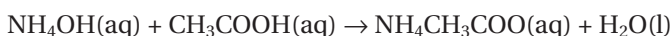


**figure 13.10** Titration curve for a weak acid vs strong base.

The equivalence point is now in the alkaline range because the salt produced is basic. As with the previous example, however, the equivalence point still falls on the steepest part of the curve. The most suitable indicator for this kind of titration is phenolphthalein (colour change pH 8.3–10.0).

## Weak acid, weak base

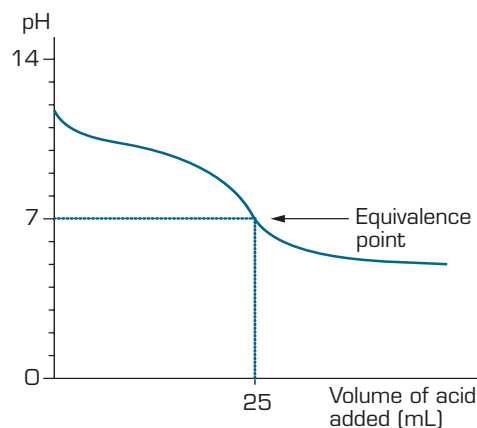
When a weak acid is reacted with a weak base, the pH of the solution at equivalence depends on the acid–base properties of the ions in the salt. A common example of this would be ethanoic acid and ammonia.



The ammonium ion acts as a proton donor (weak acid). The ethanoate ion acts as a proton acceptor (weak base). The final pH of the solution depends on the extent to which the hydrolysis of these two ions proceeds.

## Titration curves for weak acid vs weak base

Titration of 0.1 M ethanoic acid (titrant) against 25.00 mL of 0.1 M ammonia solution (analyte) is shown in figure 13.11.



**figure 13.11** Titration curve for a weak acid vs weak base.

Titration of a weak acid against a strong base produces a neutral solution  $\text{pH} > 7$ .



The acid and the base are both about equally weak, so in this case the equivalence point is approximately pH 7.

This is really just a combination of the earlier graphs. Up to the equivalence point it is similar to the ammonia–hydrochloric acid case (figure 13.9). After the equivalence point it is like the end of the ethanoic acid–sodium hydroxide curve (figure 13.10).

Notice that there is no steep section on this graph. Instead, there is just what is known as a **point of inflexion**, where the curve dips. This lack of a steep section on the curve means that it is difficult to titrate a weak acid against a weak base using a conventional indicator.



Titration of a weak acid against a weak base produces a solution whose pH depends on the acidity of the anion and cation in the salt.

## Experiment 13.5

### Titration curves for acid–base titrations

#### Purpose

To obtain a titration curve for the titration of a strong acid and a strong base.

#### Method

- 1 Calibrate the pH meter in accordance with the manufacturer's instructions.
- 2 Use a pipette to place 10.0 mL of 0.10 M hydrochloric acid in a 100 mL beaker. Add 50 mL of deionised water and three or four drops of phenolphthalein indicator.
- 3 Place the beaker on the magnetic stirrer and insert a stirrer bar in the solution.
- 4 Clamp the probe of the pH meter in the solution, ensuring it will not be struck by the stirring bar. Turn on the stirrer and set it at a low to medium speed.
- 5 Fill a burette to 0.00 mL on the scale with 0.10 M sodium hydroxide solution and clamp it above the beaker of acid.
- 6 Record the pH. Also record and enter the burette reading (0.00 mL). You may wish to enter the data directly into a computer spreadsheet program for later processing.
- 7 Add sufficient sodium hydroxide solution from the burette to change the pH reading by about 0.3 units. When the pH reading stabilises, record the exact values of pH and the burette reading.
- 8 Continue to repeat step 7 until the volume of sodium hydroxide solution added from the burette approaches the value of 10 mL and the pH begins to change rapidly. As soon as this happens add the hydroxide in 0.1 mL increments. Record the exact pH and burette reading after each increment. Also note the burette reading when the indicator changes colour.
- 9 Stop collecting data once the pH becomes almost constant.
- 10 Rinse the pH probe with distilled water and return it to the storage solution.

#### materials

- 20 mL of 0.10 M hydrochloric acid
- 30 mL of 0.10 M sodium hydroxide solution
- 70 mL deionised water
- phenolphthalein indicator
- burette
- 10 mL pipette
- 100 mL beaker
- pipette filler
- small funnel
- magnetic stirrer and stirrer bar
- stand and two clamps
- wash bottle
- pH meter (and data collection system if available)
- computer and spreadsheet program (optional)

#### safety

- Wear safety glasses and a laboratory coat for this experiment.
- Hydrochloric acid and sodium hydroxide solutions are corrosive. Avoid contact with the skin, eyes or clothing.



## Discussion

- 1 Construct a titration curve by graphing pH against the volume of sodium hydroxide solution added.
- 2 Calculate the volume of 0.10 M sodium hydroxide solution that is required to reach the equivalence point in a titration against 10.0 mL of 0.10 M hydrochloric acid. Mark on your titration curve where the equivalence point occurs.
- 3 How can the equivalence point of a titration be found from the shape of the titration curve?
- 4 Phenolphthalein indicator changes colour in the pH range 8.2 to 10.
  - a Between what burette readings did the end point occur?
  - b Why is phenolphthalein a good indicator for this titration?
- 5 Sketch the graph you would expect to observe if the hydrochloric acid had been placed in the burette and the sodium hydroxide solution was in the beaker.

## Extension activity

Repeat the titration using 0.10 M ethanoic acid (a weak acid) instead of hydrochloric acid and use methyl orange as the indicator (pH range 3.1–4.5).

Compare the shape of the titration curve with the curve for a strong acid–strong base titration. Is methyl orange a good indicator for this titration?

## Questions

- 13 For the following titrations, identify:
  - i the salt at equivalence
  - ii the pH of the solution at equivalence
  - iii a suitable indicator for the titration.
  - a hydrogen iodide and potassium carbonate
  - b oxalic acid and sodium hydroxide
  - c sodium sulfide and nitric acid
- 14 In a titration between sodium carbonate and hydrochloric acid, a student mistakenly used phenolphthalein as the indicator instead of methyl orange. What effect would this have on the student's results?

## 13.4 Titration techniques

There are a number of volumetric analysis techniques that make use of titrations. In this section we will look at acid–base titrations, back titrations and redox titrations. Each technique uses the same principles to determine the concentration of an unknown.

The concentration of the unknown solution can be determined by knowing the:

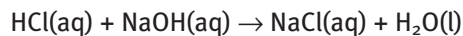
- concentration of the titrant, in  $\text{mol L}^{-1}$
- volume of the titrant added, in L
- volume of the unknown solution, in L
- equation for the reaction between the two solutions.



## Worked example 13.4A

20.00 mL of hydrochloric acid was pipetted into a conical flask, and two drops of phenolphthalein indicator were added. A 0.1019 M sodium hydroxide solution was titrated until the resulting solution turned a permanent pale pink colour. The process was repeated and the average titre was 24.20 mL.

The equation for the neutralisation reaction is:



$$\begin{aligned} n(\text{NaOH}) &= c \times V \\ &= 0.1019 \text{ mol L}^{-1} \times 0.02420 \text{ L} \\ &= 2.466 \times 10^{-3} \text{ mol} \end{aligned}$$

From the equation, 1 mol of HCl reacts with 1 mol of NaOH. The reacting ratio is:

$$\frac{n(\text{HCl})}{n(\text{NaOH})} = \frac{1}{1}$$

$$\begin{aligned} n(\text{HCl}) &= n(\text{NaOH}) \\ &= 2.466 \times 10^{-3} \text{ mol} \end{aligned}$$

$$\begin{aligned} c(\text{HCl}) &= n/V \\ &= \frac{2.466 \times 10^{-3} \text{ mol}}{0.0200 \text{ L}} = 0.1233 \text{ mol L}^{-1} \end{aligned}$$

The concentration of the hydrochloric acid is 0.1233 M.

As concentration is expressed in  $\text{mol L}^{-1}$ , all volumes used in the calculations must be in litres.

## Experiment 13.6

### Acid–base titrations

#### Purpose

To determine the concentration of an acid, by titrating it against a base.

#### Method

##### Part A

- 1 Use a pipette to place a 20.0 mL aliquot of hydrochloric acid in a conical flask.
- 2 Add three drops of phenolphthalein indicator.
- 3 Fill a burette with standard sodium hydroxide solution. Record the initial burette reading.
- 4 Place the flask on a white tile underneath the burette.
- 5 Slowly add sodium hydroxide to the flask until a colour change occurs. Record the final burette reading.
- 6 The first titration can be a rough one to give you an idea of the titre.
- 7 Repeat steps 1 and 2.
- 8 Add sodium hydroxide to the flask until you are within a couple mL of the estimated titre. Occasionally rinse the sides of the flask with distilled water. Slowly add the base until a faint permanent colour change occurs. Continue adding base drop by drop until you reach the end point. (You can get half a drop by hanging a drop from the burette and washing it in with distilled water.)

#### materials

- acid (hydrochloric acid and acetic acid)
- 0.10 M sodium hydroxide
- indicator (phenolphthalein and methyl orange)
- deionised water
- conical flasks
- 20.0 mL pipette
- 50.0 mL burette
- pipette filler
- small funnel
- burette stand
- white tile



## safety

- Wear safety glasses and a laboratory coat for this experiment.
- Hydrochloric acid and sodium hydroxide are corrosive.
- Phenolphthalein indicator may cause irritation to the skin and eyes.

- 9 Repeat the titration until you have three consistent titres, ideally within 0.10 mL of each other.

### Part B

- 1 Repeat the procedure in Part A using acetic acid as your analyte. (Use methyl orange indicator.)

### Discussion

- 1 Write a reaction equation between the sodium hydroxide and
  - a hydrochloric acid
  - b acetic acid.
- 2 For each acid, calculate the average titre of sodium hydroxide solution.
- 3 For each acid, calculate the amount of sodium hydroxide, in mol, present in the average titre of sodium hydroxide solution.
- 4 For each acid, use the reaction equation to determine the number of moles of acid in the initial 20 mL aliquot.
- 5 Calculate the concentration of each acid (in mol L<sup>-1</sup>).
- 6 Explain what is meant by a standard solution of sodium hydroxide.

If the acid or base is too weak to cause a distinct colour change of the indicator, a **back titration** is used to determine the concentration of the unknown solution.

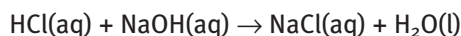
## Back titrations

A **back titration** needs to be performed when the acid or base is too weak to cause a distinct colour change of an indicator. An excess of a strong acid or base is added to the substance to be analysed. Using titration, the amount of unreacted strong acid or base can be calculated, and by working backwards, the amount of the original substance present can be determined.



### Worked example 13.4B

In order to determine the concentration of calcium hydroxide (a weak base), first an excess of hydrochloric acid was added—10.0 mL of 0.50 M HCl was added to 10 mL of a Ca(OH)<sub>2</sub> solution. The resulting solution was titrated against a 0.1135 M NaOH solution and the titre measured 21.1 mL.

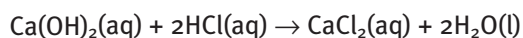


$$\begin{aligned} n(\text{NaOH}) &= c \times V \\ &= 0.1135 \times 0.211 \\ &= 0.0240 \text{ mol NaOH} \end{aligned}$$

$$n(\text{NaOH}) = n(\text{HCl}) = 0.0240 \text{ mol of excess HCl}$$

$$\begin{aligned} \text{initial } n(\text{HCl}) &= c \times V \\ &= 0.50 \times 0.010 \\ &= 0.0050 \text{ mol HCl} \end{aligned}$$

$$\begin{aligned} \text{Therefore } n(\text{HCl}) \text{ reacted with Ca(OH)}_2 &= 0.0050 - 0.0240 \\ &= 0.0026 \text{ mol HCl} \end{aligned}$$



$$\begin{aligned} \text{Therefore } \frac{n(\text{Ca(OH)}_2)}{n(\text{HCl})} &= \frac{1}{2} \\ n(\text{Ca(OH)}_2) &= \frac{n(\text{HCl})}{2} \\ &= \frac{0.0026}{2} \\ &= 0.0013 \text{ mol Ca(OH)}_2 \\ c(\text{Ca(OH)}_2) &= \frac{n}{V} \\ &= \frac{0.0013}{0.010} \\ &= 0.130 \text{ M} \end{aligned}$$

## Experiment 13.7

### Back titration

#### Purpose

To determine the purity of a sample of calcium carbonate by reacting it with excess acid and performing a back titration using sodium hydroxide.

#### Method

- 1 Accurately record the mass of approximately 1.00 g of calcium carbonate. Place in a beaker.
- 2 Add approximately 20 mL of deionised water.
- 3 Use a burette to add 50.0 mL of hydrochloric acid. Leave until the reaction stops bubbling. The solution may be gently heated to speed up this process.
- 4 Transfer the solution to a 250.0 mL volumetric flask, ensuring you rinse the beaker with deionised water and add to the flask also. Make up to the mark with deionised water.
- 5 Pipette 20.0 mL of this solution into a conical flask.
- 6 Add three drops of phenolphthalein indicator.
- 7 Fill a burette with standard sodium hydroxide. Record the initial burette reading.
- 8 Place the flask on a white tile underneath the burette.
- 9 Add sodium hydroxide to the flask until a permanent faint pink colour change occurs. Record the final burette reading.
- 10 Repeat the titration until you have three consistent titres (within 0.10 mL of each other).

#### Discussion

- 1 Write a reaction equation between:
  - a calcium carbonate and hydrochloric acid
  - b hydrochloric acid and sodium hydroxide.

#### materials

- 1.0 M hydrochloric acid
- 0.1 M sodium hydroxide
- calcium carbonate
- phenolphthalein indicator
- deionised water
- beaker
- conical flasks
- 250.0 mL volumetric flask
- 20.0 mL pipette
- 50.0 mL burette
- pipette filler
- small funnel
- burette stand
- measuring cylinder
- white tile
- electronic balance
- heating element
- spatula

#### safety

- Wear safety glasses and a laboratory coat for this experiment.
- Hydrochloric acid and sodium hydroxide are corrosive.
- Phenolphthalein indicator may cause irritation to the skin and eyes.

- Calculate the number of moles of hydrochloric acid added to the 250.0 mL flask.
- Calculate the number of moles of hydrochloric acid in the 20.0 mL aliquot.
- Calculate the average titre of sodium hydroxide solution.
- Calculate the number of moles of sodium hydroxide in the average titre.
- Use the appropriate reaction equation to determine the number of moles of excess hydrochloric acid (in 250.0 mL).
- Calculate the number of moles of hydrochloric acid that reacted initially.
- Use the appropriate reaction equation to determine the number of moles of calcium carbonate in the sample.
- Determine the mass of calcium carbonate in the sample.
- Calculate the percentage purity of the calcium carbonate.

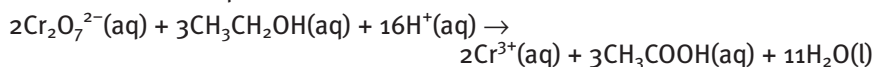
## Redox titrations

The technique for a redox titration is the same as for an acid–base titration. Examples of redox titrations include the determination of concentrations of ethanol in wine, hypochlorite ions in bleach or vitamin C in fruit juice. Sometimes an indicator is not necessary as the substances being analysed change colour at the equivalence point.

### Worked example 13.4C

The alcohol content of an imported brandy was found by taking 10.0 mL, and diluting it to 500.0 mL. 20.00 mL aliquots of this solution were then titrated against 0.100 M acidified potassium dichromate ( $\text{K}_2\text{Cr}_2\text{O}_7$ ) solution. The average titre was 17.98 mL. Calculate the concentration of ethanol in the sample of brandy.

Write a balanced equation.



Calculate the amount of  $\text{Cr}_2\text{O}_7^{2-}$  used in the titration.

$$\begin{aligned} n(\text{Cr}_2\text{O}_7^{2-}) &= c \times V \\ &= 0.100 \text{ M} \times 0.01798 \text{ L} \\ &= 0.001798 \text{ mol} \end{aligned}$$

From the reaction equation, 3 mol of  $\text{CH}_3\text{CH}_2\text{OH}$  reacts with 2 mol  $\text{Cr}_2\text{O}_7^{2-}$ .

$$\frac{n(\text{CH}_3\text{CH}_2\text{OH})}{n(\text{Cr}_2\text{O}_7^{2-})} = \frac{3}{2}$$

$$\begin{aligned} n(\text{CH}_3\text{CH}_2\text{OH}) \text{ in } 20.00 \text{ mL aliquots} &= \frac{3}{2} \times n(\text{Cr}_2\text{O}_7^{2-}) \\ &= \frac{3}{2} \times 0.001798 \text{ mol} \\ &= 0.002697 \text{ mol} \end{aligned}$$

Calculate the amount of  $\text{CH}_3\text{CH}_2\text{OH}$  in the 500.0 mL flask. Remember only 20.00 mL was removed from the 500.0 mL flask for the titration.

$$\begin{aligned} n(\text{CH}_3\text{CH}_2\text{OH}) \text{ in } 500.0 \text{ mL} &= 0.002697 \times \frac{500.0}{20.00} \text{ mol} \\ &= 0.06743 \text{ mol} \end{aligned}$$

This is the same amount of  $\text{CH}_3\text{CH}_2\text{OH}$  as is present in the 10.00 mL sample. Calculate the concentration of  $\text{CH}_3\text{CH}_2\text{OH}$  in the 10.00 mL sample.

$$c(\text{CH}_3\text{CH}_2\text{OH}) \text{ in the } 10.00 \text{ mL sample} = \frac{0.06743 \text{ mol}}{0.0100 \text{ L}} = 6.74 \text{ M}$$

## Experiment 13.8

### Redox titration

#### Purpose

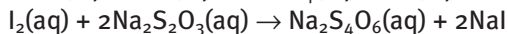
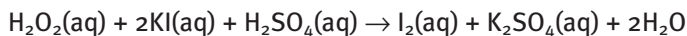
To determine the percentage of hydrogen peroxide in a solution.

#### Method

- 1 Transfer 20.0 mL of the hydrogen peroxide solution to a 250.0 mL volumetric flask using a pipette.
- 2 Make up to the mark with deionised water.
- 3 Fill a burette with standard sodium thiosulfate solution. Record the initial burette reading and the concentration of the sodium thiosulfate solution.
- 4 Transfer 20.0 mL of the diluted hydrogen peroxide solution to a conical flask. Add approximately 5 mL of 0.1 M potassium iodide solution, approximately 5 mL of 1 M sulfuric acid and three drops of 3% ammonium molybdate. Swirl to mix. The solution will turn a dark brown as iodine is formed.
- 5 Place the flask on a white tile underneath the burette.
- 6 Titrate with the sodium thiosulfate solution until the resulting mixture becomes pale.
- 7 Add 1–2 mL of starch indicator solution, turning the solution blue. It is important that this is not added too early.
- 8 Continue to titrate until the blue colour just disappears. Record the final burette reading.
- 9 Repeat the procedure until three consistent titres have been obtained.

#### Discussion

The equations for the titration are:



- 1 Find the average of the three consistent titres of sodium thiosulfate solution.
- 2 Using the concentration of the standard sodium thiosulfate solution, calculate the amount (in mol) of sodium thiosulfate in the average titre.
- 3 Use the appropriate half equation to determine the amount of  $\text{I}_2$  present in the volumetric flask.
- 4 Use the appropriate half equation to determine the amount of  $\text{H}_2\text{O}_2$  in each 20.0 mL aliquot of diluted hydrogen peroxide.
- 5 Calculate the amount, in mol, of  $\text{H}_2\text{O}_2$  in the 250.0 mL flask of diluted hydrogen peroxide.
- 6 Calculate the molarity of the hydrogen peroxide solution.
- 7 Calculate the mass of hydrogen peroxide in the 250.0 mL flask.
- 8 Calculate the percentage of hydrogen peroxide in solution. (Assume the density is  $1.0 \text{ g mL}^{-1}$ ).

#### materials

- hydrogen peroxide solution
- 0.1 M potassium iodide solution
- 1 M sulfuric acid
- ~0.1 M sodium thiosulfate solution
- starch indicator solution
- 3% ammonium molybdate solution
- deionised water
- 250.0 mL volumetric flask
- pipettes
- pipette filler
- conical flasks
- 10 mL measuring cylinder
- 50 mL burette
- burette stand and clamp
- small funnel
- white tile

#### safety

- Wear safety glasses and a laboratory coat for this experiment.
- Sulfuric acid is corrosive.
- Sodium thiosulfate and potassium iodide may cause irritation to the skin and eyes.
- Hydrogen peroxide is an irritant to the skin and eyes, and is harmful if swallowed.
- Ammonium molybdate is an irritant to the skin and eyes, and is harmful if swallowed or inhaled.

## Questions

- 15 Explain the difference between the following terms.
- equivalence point and end point
  - burette and pipette
  - aliquot and titre
- 16 A 42.7 mL volume of a hydrochloric acid solution is required to react completely with 20.0 mL of 0.612 M sodium carbonate solution.
- Write an equation for the reaction.
  - Calculate the concentration of the hydrochloric acid, in mol L<sup>-1</sup>.
- 17 A solution of sodium carbonate was prepared by dissolving 1.217 g of anhydrous sodium carbonate in 250.0 mL of water. Aliquots of this solution, each with a volume of 20.00 mL, were then titrated with a hydrochloric acid solution of unknown concentration, using methyl orange indicator to identify the end point of the titration. The average titre recorded was 17.85 mL. Calculate the concentration of the hydrochloric acid solution.
- 18 A 25.0 mL sample of cloudy ammonia was placed in a volumetric flask and diluted to 250.0 mL. A 20.0 mL aliquot of this solution was titrated with 0.0987 M hydrochloric acid. The volume of the acid used was 22.18 mL. The equation for the reaction is:
- $$\text{NH}_3(\text{aq}) + \text{HCl}(\text{aq}) \rightarrow \text{NH}_4\text{Cl}(\text{aq})$$
- Calculate the amount of hydrochloric acid, in mol, used in the titration.
  - Calculate the amount of ammonia, in mol, used in the titration.
  - Calculate the concentration of ammonia in the diluted solution used in the titration.
  - Calculate the concentration of ammonia in the original sample.
- 19 A 0.4376 g aspirin tablet was heated gently with 50.00 mL of 0.196 M sodium hydroxide solution. The aspirin reacts according to the equation:
- $$\text{C}_6\text{H}_4(\text{OCOCH}_3)\text{COOH}(\text{aq}) + 2\text{NaOH}(\text{aq}) \rightarrow \text{C}_6\text{H}_4(\text{OH})\text{COONa}(\text{aq}) + \text{CH}_3\text{COONa}(\text{aq}) + \text{H}_2\text{O}(\text{l})$$
- After cooling, the resulting solution was back titrated against 0.298 M hydrochloric acid to determine the amount of unreacted sodium hydroxide. A titre of 18.64 mL was obtained. Calculate:
- the amount, in mol, of sodium hydroxide initially added to the aspirin
  - the amount of hydrochloric acid used
  - the amount of sodium hydroxide in excess after reaction with the aspirin
  - the amount of sodium hydroxide that reacted with the aspirin
  - the amount of aspirin in the tablet
  - the percentage, by mass, of aspirin in the tablet.
- 20 A 1.306 g tablet containing vitamin C (C<sub>6</sub>H<sub>8</sub>O<sub>6</sub>) was crushed and dissolved in deionised water. The solution was titrated against 0.0500 M iodine solution, using starch solution as the indicator. The redox reaction can be represented by the equation:
- $$\text{C}_6\text{H}_8\text{O}_6(\text{aq}) + \text{I}_2(\text{aq}) \rightarrow \text{C}_6\text{H}_6\text{O}_6(\text{aq}) + 2\text{H}^+(\text{aq}) + 2\text{I}^-(\text{aq})$$
- The end point occurred when 28.40 mL of iodine solution had been added.
- Find the mass of vitamin C in the tablet.
  - Calculate the percentage of vitamin C in the tablet by mass.
  - Suggest the function of the other substances that make up the remainder of the mass of the tablet.



## Summary ▶▶▶▶

- ▶ **Gravimetric analyses** involve various techniques that depend on the measurement of mass.
- ▶ For any mixture or compound the **percent composition** by mass can be determined using the ratio between the mass of the individual components and the total mass.
- ▶ If the mass of each element in a compound is known, its **empirical formula** can be identified. The empirical formula of a compound shows the lowest whole-number ratio of elements present. If the molar mass of the compound is known the **molecular formula** of the compound, which shows the actual number of atoms of each element present, can also be determined.
- ▶ Gravimetric analysis can also be used to determine the amount of water in a mixture or the number of water molecules attached to the crystal of an ionic substance. A compound without water attached is **anhydrous** and **hydrous** if there are water molecules attached. The attached water is called **water of crystallisation**.
- ▶ A **desiccant** is a **hygroscopic** substance that is used to absorb water from the air. If the hygroscopic substance absorbs enough water to form a solution it is referred to as **deliquescent**.
- ▶ **Titration** is a process used in **volumetric analysis** where a **standard solution** of known concentration and volume is reacted with a solution of known volume but unknown concentration. A **primary standard** is used to prepare the standard solution. Titrations commonly involve acid–base reactions, but can also be used for redox reactions.
- ▶ An **indicator** is used to identify the **equivalence point** of a titration, where the substances have reacted completely according to the reaction equation. The indicator changes colour at the **end point**, which is very close to the equivalence point. The indicator must be carefully chosen using a **titration curve** so that the colour change occurs close to the equivalence point.
- ▶ A titration between a **strong acid** and a **strong base** produces a **neutral salt**. A titration between a **strong acid** and **weak base** produces an **acidic salt**. A titration between a **weak acid** and **strong base** produces a **basic salt**. The colour change of the chosen indicator must match the pH of the solution at equivalence.
- ▶ If the reacting acid or base is too weak to cause a distinct colour change, a **back titration** needs to be performed.

## Key terms ▶▶

acidic salt

anhydrous

back titration

basic salt

deliquescent

desiccant

empirical formula

end point

equivalence point

gravimetric analysis

hydrous

hygroscopic

indicator

molecular formula

neutral salt

percent composition

primary standard

standard solution

strong acid

strong base

titration

titration curve

volumetric analysis

water of crystallisation

weak acid

weak base



## Chapter Review

### 13.1 Gravimetric analysis

- 21 The concentration of sodium chloride in a brackish (slightly salty) stream was found by precipitation of the chloride ion with silver nitrate solution by gravimetric analysis.
- Write a balanced equation for the reaction.
  - Name two characteristics that a precipitate should have if it is to be suitable for gravimetric analysis.
  - The following steps are commonly used in gravimetric analysis.
    - Wash the precipitate with a small volume of water.
    - Add excess silver nitrate solution.
    - Weigh the precipitate.
    - Measure a known mass or volume of the sample to be tested into a beaker.
    - Filter the precipitate formed.
    - Dry in an oven at 110°C.Put the steps into the correct sequence for the gravimetric analysis of sodium chloride.
  - Explain how the following errors would affect the calculated concentration of sodium chloride as either too high, too low or no effect.
    - Precipitate not washed with water.
    - Sample not dried completely.
- 22 Solutions of silver nitrate and potassium chromate react to produce a red precipitate of silver chromate.
- $$2\text{AgNO}_3(\text{aq}) + \text{K}_2\text{CrO}_4(\text{aq}) \rightarrow \text{Ag}_2\text{CrO}_4(\text{s}) + 2\text{KNO}_3(\text{aq})$$
- If 0.778 g of precipitate is formed, find:
- the mass of potassium chromate that reacted
  - the mass of silver nitrate that reacted.
- 23 Calculate the percentage by mass of each element in the following compounds.
- $\text{Al}_2\text{O}_3$
  - $\text{Cu}(\text{OH})_2$
  - $\text{MgCl}_2 \cdot 6\text{H}_2\text{O}$
  - $\text{Fe}_2(\text{SO}_4)_3$
- 24 Silicon steel is an alloy of the elements iron, carbon and silicon. An alloy sample was reacted with excess hydrochloric acid and the following reaction occurred:
- $$\text{Fe}(\text{s}) + 2\text{HCl}(\text{aq}) \rightarrow \text{FeCl}_2(\text{aq}) + \text{H}_2(\text{g})$$
- The carbon and silicon in the alloy did not react with the acid. If an alloy sample with a mass of 0.160 g produced 62.0 mL of hydrogen gas, measured at SLC, calculate:
- the amount of hydrogen evolved in the reaction

- the mass of iron that reacted to produce this hydrogen
  - the percentage of iron in the steel alloy.
- 25 A 0.693 g sample of a silver alloy used to make cutlery is dissolved completely in nitric acid. Excess sodium chloride solution is added to precipitate silver chloride. The precipitate is filtered, dried and found to weigh 0.169 g.
- Find the percentage of silver in the alloy.
  - If the precipitate was not completely dry when weighed, what effect would this have on the answer for part a?
- 26 An impure sample of iron(II) sulfate, weighing 1.545 g, was treated to produce a precipitate of  $\text{Fe}_2\text{O}_3$ . If the mass of the dried precipitate was 0.315 g, calculate the percentage of iron in the sample.
- 27 Some shavings of a magnet known to be made of a nickel alloy were reacted with nitric acid. Dimethylglyoxime solution was added to produce a bright red precipitate of nickel dimethylglyoxime ( $\text{Ni}(\text{C}_4\text{H}_7\text{O}_2\text{N}_2)_2$ ). The precipitate was then filtered and collected using a Gooch crucible, washed and dried in an oven at 110°C. The following experimental data were recorded:
- mass of alloy = 0.102 g  
mass of Gooch crucible = 23.515 g  
mass of Gooch crucible + precipitate:
- first weighing = 24.996 g  
second weighing = 23.651 g  
third weighing = 23.650 g
- Calculate the percentage, by mass, of nickel in the alloy.
  - Explain why the mass of the precipitate changed from the first to second weighing.
  - How would your result for part a be affected if only one weighing had been made?

### 13.2 Empirical and molecular formulae

- 28 Determine the molecular formulae of compounds with the following compositions and relative molecular masses.
- 82.75% carbon, 17.25% hydrogen;  $M = 58$
  - 43.66% phosphorus, 56.34% oxygen;  $M = 284$
  - 40.0% carbon, 6.7% hydrogen, 53.3% oxygen;  $M = 180$
  - 0.164 g hydrogen, 5.25 g sulfur, 9.18 g oxygen;  $M = 178$
  - 54.5% carbon, 9.1% hydrogen, 36.4% oxygen;  $M = 88$
  - 8.47 g carbon, 0.471 g hydrogen, 3.29 g nitrogen, 7.53 g oxygen;  $M = 168$

- 29 Xylene, a colourless organic liquid, is used as an industrial solvent. A 9.0 g sample of xylene, equivalent to 0.085 mol, was found to contain 90.6% carbon and 9.4% hydrogen. Determine the empirical and molecular formulae of xylene.
- 30 If 3.72 g of element X exactly reacts with 4.80 g of oxygen to form a compound whose molecular formula is shown from other experiments to be  $X_4O_{10}$ , what is the relative atomic mass of X?
- 31 The empirical formula of a metal oxide can be found by experimentation. The mass of the metal and the mass of the oxygen that reacts with it must be determined. The six steps in the experimental method are listed in the box below.

- A Ignite a burner and heat the metal.  
 B Allow the crucible to cool, then weigh it.  
 C Continue the reaction until no further change occurs.  
 D Clean a piece of metal with the emery paper to remove any oxide layer.  
 E Place the metal in a clean, weighed crucible and cover with a lid.  
 F Weigh the metal and record its mass.

- a Place the steps in the correct order by letter.  
 b Wan and Eric collected the following data:  
 mass of the metal = 0.542 g  
 mass of the empty crucible = 20.310 g  
 mass of the crucible and metal oxide = 21.068 g  
 They found from this data that the metal oxide had a 1 : 1 formula, i.e. MO, where M = metal. Complete table 13.5, using the data given.

table 13.5

	Metal	Oxygen
mass (g)		
relative atomic mass		
moles		
ratio		

- c What metal was used in the experiment?
- 32 If a compound containing carbon and hydrogen is burned in air or oxygen, carbon dioxide and water are formed. Methyl salicylate is commonly known as oil of wintergreen and is often used in medical rubs. A 20.00 g sample of methyl salicylate, which contains carbon, hydrogen and oxygen only, was burnt in oxygen. The mass of water and carbon dioxide obtained was 9.47 g and 46.30 g, respectively. Calculate the empirical formula of methyl salicylate.
- 33 A 2.33 g sample of an unknown organic compound was extracted from plant material. When burnt in oxygen, the hydrogen in the compound was converted to 1.32 g of  $H_2O$ , the carbon to 3.23 g of  $CO_2$  and the remainder of the compound was oxygen.
- a Find the empirical formula of the compound.  
 b A further sample was analysed by mass spectrometry and found to have a molar mass of  $60.0 \text{ g mol}^{-1}$ . What is the molecular formula of the compound?
- 34 A sample of blue copper(II) sulfate crystals weighing 2.55 g is heated and decomposes to produce 1.63 g of anhydrous copper(II) sulfate. Show that the formula of the blue crystals is  $CuSO_4 \cdot 5H_2O$ .
- 35 A 10 g sample of blue hydrated copper(II) sulfate is heated in a crucible over a Bunsen flame until the crystals have turned white. The mass of the white residue is found to be 6.9 g. Assume that the mass lost is due to loss of the water of hydration.

The most likely explanation for the difference between the calculated and the expected empirical formula of hydrated copper sulfate ( $CuSO_4 \cdot 5H_2O$ ) is because:

- A the sample was not heated sufficiently strongly to drive off all the water.  
 B the sample was heated so strongly that some of the copper sulfate decomposed to form copper oxide.  
 C some of the white residue is ash from the Bunsen flame.  
 D some of the white residue was lost before weighing as a lid was not used.
- 36 Alumina (aluminium oxide,  $Al_2O_3$ ) is produced in North Queensland and shipped worldwide for the production of aluminium. It is sold by weight and buyers are concerned that the alumina does not contain water. The alumina must not contain more than 1.0% water. The amount of water in a sample of alumina was measured in the laboratory. A sample of alumina was weighed accurately, heated in an oven, cooled in a desiccator and reweighed. The cycle of heating and reweighing was repeated until the mass was constant. The data obtained is shown:  
 initial mass of alumina = 34.8 g  
 second mass, after heating = 34.2 g  
 third mass, after further heating = 33.9 g  
 fourth mass, after further heating = 33.9 g
- a What was the total mass of water lost?  
 b Calculate the percentage of water in the sample of alumina.  
 c What is a suitable temperature to heat the sample?

- d Why must the sample be cooled in a desiccator?
- e Why is a fourth weighing needed as no more water is lost?
- f Would the concentration of water in this sample of alumina be within the specification for sale?

## 13.3 Volumetric analysis

- 37 Figure 13.12 shows a filled burette. What is the volume that should be recorded for the burette reading?

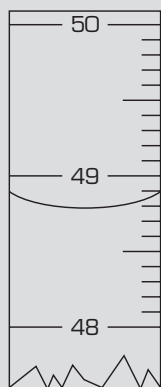


figure 13.12

- 38 The following paragraph describes an acid–base titration. Some of the key words are missing. Use the words below to fill in the gaps.
- pipette, measuring cylinder, beaker, volumetric flask, primary standard, base, standard solution, burette, indicator, titre, desiccator, aliquot

An approximate 2 g sample of anhydrous sodium carbonate is accurately weighed. (The solid must be dry if it is to be used as a \_\_\_\_\_.) The solid is tipped into a \_\_\_\_\_ and shaken with about 50 mL of distilled water until the solid dissolves. More water is added to make the solution to a volume of exactly 100.0 mL. A 20.00 mL \_\_\_\_\_ of the solution is taken by using a \_\_\_\_\_ and placed in a conical flask. A few drops of methyl orange are added and the mixture is titrated against dilute hydrochloric acid.

- 39 Explain why methyl orange would not be a suitable indicator for a titration between ethanoic acid and sodium hydroxide. If the sodium hydroxide was the titrant, how would the volume at the colour change differ from what it should be at equivalence?

- 40 The titration curve of an acid–base reaction was measured by taking continuous readings from a pH electrode in the conical flask (figure 13.13). Solution A (0.1 M, 5.0 mL) was placed in a conical flask and titrated against 0.1 M solution B.

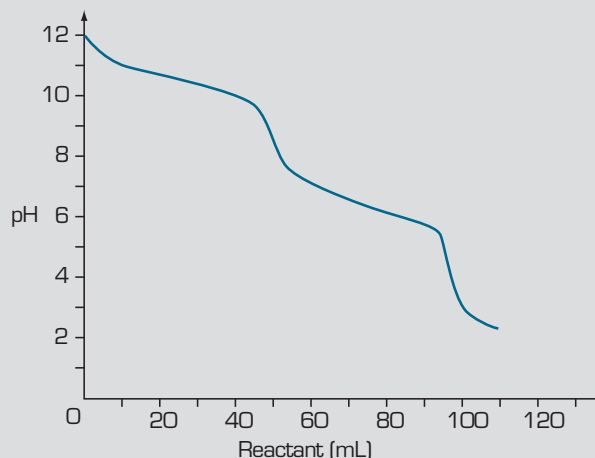


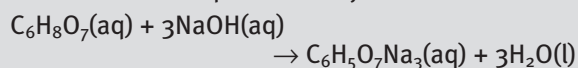
figure 13.13

Possible reactants and indicators are hydrochloric acid, acetic (ethanoic) acid, ammonia solution, sodium carbonate solution, sodium hydroxide, methyl orange (end point pH 3.2–4.4), phenolphthalein (end point pH 8.2–10.0).

- a Which reactant in the conical flask could account for the titration curve shown?
- b Give the pH values at which the equivalence points occur.
- c Suggest an appropriate indicator to determine the first equivalence point.
- d Write a chemical equation, using appropriate reagents, describing the reaction that is represented by the second equivalence point.
- e Distinguish between the terms equivalence point and end point in a titration.

## 13.4 Titration techniques

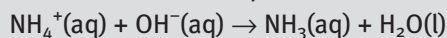
- 41 What mass of sodium sulfate is produced when 25.0 mL of 0.100 M sulfuric acid is added to 20.0 mL of 0.150 M sodium hydroxide solution?
- 42 The citric acid content of a sample of orange juice can be determined by titration with sodium hydroxide solution. A 26.3 g sample of orange juice was diluted to 250.0 mL using a volumetric flask. A 25.0 mL sample of the diluted juice was titrated with 0.0114 M sodium hydroxide solution, using phenolphthalein indicator. The reaction can be represented by:



- 22.37 mL of sodium hydroxide solution was required to reach the end point.
- Why was the juice diluted before titration?
  - Calculate the percentage by mass of citric acid in the orange juice.
- 43** The active ingredient in a brand of antacid is magnesium carbonate. A 1.30 g tablet was crushed and placed in a conical flask. A small volume of water was added, the mixture stirred, and methyl orange indicator added. The indicator changed colour permanently after 27.75 mL of 1.00 M hydrochloric acid had been added.
- Describe the changes that would be observed in the colour of the indicator.
  - Write an equation for the reaction that occurs during the titration.
  - Calculate the amount, in mol, of hydrochloric acid used to reach the end point.
  - Calculate the percentage by mass of magnesium carbonate in the tablet.
  - What is the function of the substances that make up the remaining mass of the tablet?
  - Why do people often burp after taking an antacid tablet?
- 44** A 50.0 mL sample of vinegar was diluted to 250.0 mL in a volumetric flask. A 20.00 mL aliquot of this solution required the addition of 27.98 mL of 0.1340 M sodium hydroxide solution in order to be neutralised.
- Write an equation for the neutralisation reaction.
  - What is the molarity of ethanoic acid in the original vinegar?
  - Express your answer to part b in  $\text{g L}^{-1}$ .
- 45** A solution of a metal carbonate with the formula  $\text{M}_2\text{CO}_3$  was prepared by dissolving 2.80 g of the solid in 250 mL of water. 20.00 mL aliquots of this solution were then titrated with 0.150 M  $\text{H}_2\text{SO}_4$ , using methyl orange indicator. The average titre was 10.8 mL.
- Write an equation for the reaction between the metal carbonate and sulfuric acid.
  - What amount of sulfuric acid, in mol, was needed to reach the end point of the titration?
  - What amount of the metal carbonate was present in each 20.00 mL aliquot?
  - What amount of metal carbonate was present in the original sample?
  - Determine the molar mass of the metal carbonate.
  - What is the identity of the metal M?
- 46** 10 g of sodium carbonate and 10 g of sodium hydroxide were mixed and then dissolved in water. What volume of 0.10 M hydrochloric acid is needed to neutralise the solution?
- 47** A student wishes to prepare a standard solution of a base for an acid–base titration. She chooses to weigh the required amount of anhydrous sodium carbonate, dissolve the solid in water and make up the volume in a volumetric flask. The 0.0500 M standard sodium carbonate solution is then used to determine the amount of hydrochloric acid in a sample of concrete cleaner. 20.00 mL of the diluted concrete cleaner is pipetted into the conical flask. After several titrations an average titre of 23.45 mL is obtained and the concentration of the hydrochloric acid is calculated.
- Distinguish between the terms primary standard and standard solution.
  - List three features that make anhydrous sodium carbonate a suitable choice of solid to use to prepare the standard solution.
  - What is the concentration of hydrochloric acid in the diluted concrete cleaner?
  - Determine the effect of the following errors on the final calculated value of the hydrochloric acid concentration.
    - The burette was rinsed with water.
    - The conical flask was rinsed with hydrochloric acid.
- 48** A milky white liquid antacid formulation contains a mixture of magnesium hydroxide and aluminium hydroxide. A 20.0 mL sample of the antacid is diluted to 200 mL with water. A 20.0 mL sample of the diluted solution is diluted again to 200 mL. A 20.0 mL aliquot of this solution requires 24.2 mL of 0.0521 M HCl for neutralisation.
- Give a reason for diluting the antacid formulation.
  - Write an ionic equation for the neutralisation reaction that occurs.
  - Calculate the number of moles of  $\text{OH}^-$  in the aliquot of sample titrated.
  - Calculate the number of moles of  $\text{OH}^-$  in the 20.0 mL sample of antacid before dilution. The 20.0 mL sample of antacid was found to contain 2.00 g magnesium hydroxide, the remainder was aluminium hydroxide.
  - Calculate the number of moles of hydroxide in the magnesium hydroxide in the sample.
  - Determine the moles and mass of aluminium hydroxide needed to provide the remaining hydroxide.
  - List the glassware equipment you would need to carry out this experiment.
  - For each piece of glassware indicate whether it should be rinsed with hydrochloric acid, undiluted antacid, diluted antacid or water.



- 49 Lawn fertiliser contains ammonium ions ( $\text{NH}_4^+$ ). A 1.234 g sample of lawn fertiliser was dissolved in water to make a 250.0 mL solution. A 20.00 mL aliquot of this solution was added to a flask containing 20.00 mL of 0.1022 M sodium hydroxide solution. The flask was heated until the reaction was complete.



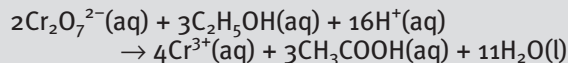
Excess sodium hydroxide in the resulting solution was titrated with 0.1132 M hydrochloric acid, using phenolphthalein as indicator. The end point was reached when 9.97 mL had been added. Calculate:

- the amount, in mol, of hydrochloric acid used in the titration
  - the amount of sodium hydroxide in excess after reaction with the fertiliser
  - the amount of sodium hydroxide that reacted with the  $\text{NH}_4^+$  ions
  - the amount of  $\text{NH}_4^+$  ions in the 1.234 g fertiliser sample
  - the percentage by mass of nitrogen in the fertiliser, assuming nitrogen is only present as ammonium ions.
- 50 An impure sample of limestone, mainly calcium carbonate, was analysed by using a back titration. Approximately 1 g of the finely powdered limestone was accurately weighed into a conical flask. An excess of the hydrochloric acid, exactly 50.00 mL, was added to the limestone. The mixture was stirred for 15 minutes with a magnetic stirrer to allow the reaction to be completed. The hydrochloric acid was titrated with a standard solution of sodium hydroxide. The following results were obtained:
- mass of conical flask = 8.795 g  
mass of conical flask and limestone = 9.846 g  
concentration of standard NaOH solution = 0.048 90 M  
titration value of NaOH obtained = 22.32 mL  
concentration of HCl = 0.3950 M
- Write balance equations for the two reactions that occur.
  - Determine the moles of hydrochloric acid in excess after the reaction with the limestone.
  - Calculate the total moles of hydrochloric acid added to the limestone.
  - How many moles of hydrochloric acid reacted with the limestone?
  - Calculate the number of moles of calcium carbonate in the limestone.
  - What is the percentage of calcium carbonate in the limestone?

- g In this experiment the whole sample of limestone was used in one titration. How could the precision of the titration have been improved?

- 51 The iron content in a 0.200 g sample of fencing wire was determined by dissolving the wire in dilute sulfuric acid and making up the resulting pale green solution of  $\text{Fe}^{2+}$  ions to 25 mL. The solution was titrated with 0.0300 M potassium permanganate ( $\text{KMnO}_4$ ) solution, which is purple in colour. A titre of 20.22 mL was obtained. The solution of  $\text{Mn}^{2+}$  and  $\text{Fe}^{3+}$  ions produced by the reaction was almost colourless.

- Write an overall equation for the titration reaction.
  - Calculate the amount, in mol, of  $\text{Fe}^{2+}$  ions in the 25 mL volume of solution.
  - Calculate the percentage, by mass, of iron in the wire.
  - An indicator was not required for this titration. Why not?
  - Briefly describe two safety precautions that should be observed when carrying out this titration.
- 52 A Food and Drugs Authority analysed a sample of light beer to see if it conformed with the regulation of a maximum of 2% by mass of alcohol (ethanol). The alcohol content was determined by volumetric analysis using the reaction:



The beer was tested by taking a 10.00 mL sample and making it up to 250 mL in a standard flask. 20.00 mL aliquots were titrated against a 0.0500 M solution of potassium dichromate ( $\text{K}_2\text{Cr}_2\text{O}_7$ ). Three separate titrations gave titres of 9.20 mL, 9.16 mL and 9.22 mL.

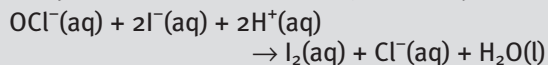
- Calculate:
  - the amount, in mol, of  $\text{Cr}_2\text{O}_7^{2-}$  present in the average of the titres
  - the amount, in mol, of ethanol present in each 20.00 mL aliquot
  - the amount, in mol, of ethanol in the original 10.00 mL sample of beer
  - the mass of ethanol in the original sample
  - the percentage by mass of alcohol in the beer, if the density of light beer is  $1.10 \text{ g mL}^{-1}$ .
- Would this product conform with the regulations for low alcohol beer?

**53** Megavit multivitamin tablets contain iron(II) sulfate as one of their ingredients. The iron content of a sample of Megavit tablets was analysed. Ten tablets were crushed and ground into a paste with a little dilute sulfuric acid. All of the paste was carefully transferred into a 250.0 mL volumetric flask and the solution was made up to the mark with more dilute sulfuric acid.

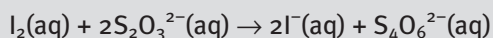
20.00 mL aliquots of the solution were titrated with 0.0200 M potassium permanganate solution. A mean titre of 12.95 mL was obtained.

- Write the half equation for the oxidation of  $\text{Fe}^{2+}$  to  $\text{Fe}^{3+}$ .
- Write the half equation for the reduction of purple  $\text{MnO}_4^-$  to colourless  $\text{Mn}^{2+}$  in acidic solution.
- Write a balanced ionic equation to represent the overall reaction.
- Calculate the amount, in mol, of  $\text{Fe}^{2+}$  present in each aliquot.
- Calculate the amount of  $\text{Fe}^{2+}$  in the 250.0 mL volumetric flask.
- Calculate the mass of iron(II) sulfate present in each tablet.
- The label on the bottle of Megavit tablets says that each tablet contains 250 mg  $\text{FeSO}_4$ . How do your results compare with the manufacturer's specification? List two possible sources of error that could account for any discrepancy.

**54** The active ingredient in bathroom mould killers is the bleaching agent sodium hypochlorite ( $\text{NaOCl}$ ). The concentration of this chemical in a 20.00 mL sample was determined by adding an acidified solution containing an excess of  $\text{I}^-$  ions to the sample. This reacted according to the equation:



The iodine formed by this reaction was titrated using 0.750 M sodium thiosulfate ( $\text{Na}_2\text{S}_2\text{O}_3$ ) solution.



25.10 mL of the thiosulfate solution was required to reach the end point.

Calculate:

- the amount, in mol, of  $\text{I}_2$  reacting with the  $\text{S}_2\text{O}_3^{2-}$  ions
  - the amount of  $\text{NaOCl}$  in the sample
  - the percentage of  $\text{NaOCl}$ , by mass, in the mould killer. (Assume the density of the solution is  $1.0 \text{ g mL}^{-1}$ .)
- 55** A standard solution of sodium oxalate,  $\text{Na}_2\text{C}_2\text{O}_4$ , was prepared for a redox titration. An accurately known solution of approximately 0.05 M sodium oxalate was required for the titration.
- What mass of sodium oxalate would give a 0.0500 M solution if a 250 mL volumetric flask was used for the dilution?
  - Explain why the accuracy of the titration is not affected if the exact mass calculated in part a is not used.
- 56** A vitamin C (ascorbic acid,  $\text{C}_6\text{H}_8\text{O}_6$ ) tablet, total mass 0.537 g, was analysed by titration to determine the amount of ascorbic acid it contained. The tablet was dissolved in 50 mL of water. An excess of iodine, 50 mL of 0.0490 M  $\text{I}_2$  solution, was added to the dissolved tablet. The excess iodine was titrated with 0.0213 M thiosulfate. The titre recorded was 28.45 mL.
- $$\text{C}_6\text{H}_8\text{O}_6(\text{aq}) + \text{I}_2(\text{aq}) \rightarrow \text{C}_6\text{H}_6\text{O}_6(\text{aq}) + 2\text{H}^+(\text{aq}) + 2\text{I}^-(\text{aq})$$
- $$\text{I}_2(\text{aq}) + 2\text{S}_2\text{O}_3^{2-}(\text{aq}) \rightarrow 2\text{I}^-(\text{aq}) + \text{S}_4\text{O}_6^{2-}(\text{aq})$$
- Why is a back titration sometimes used instead of a direct titration?
  - Calculate the number of moles of vitamin C in the tablet.
  - If the volume of the water used to dissolve the tablet was less than 50 mL, what effect would there be on the calculated concentration of vitamin C?
  - If the volume of excess iodine added to the dissolved tablet was less than 50 mL, what effect would there be on the calculated concentration of vitamin C?



# 14

## Instrumental and specialised techniques

Chemical substances can be identified by their appearance, physical properties and by observing the chemical reactions they take part in. For some chemical compounds these properties are very similar and the observations may be inconclusive. Chemists have developed a number of instrumental techniques that allow fast accurate assessment of a chemical substance. These techniques use electronic equipment to make extremely accurate measurements of the properties of an element or compound.

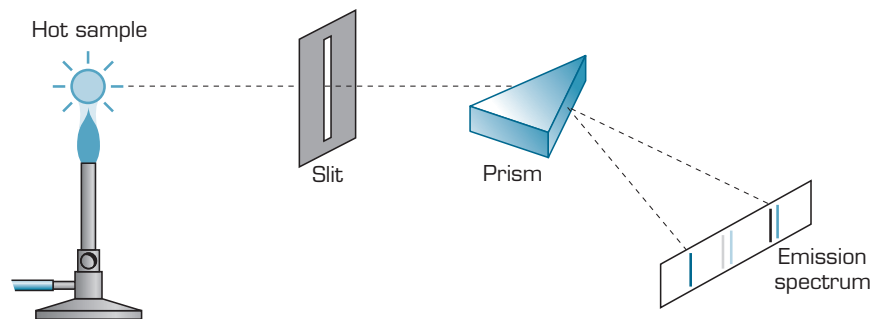
### 14.1 Atomic emission spectroscopy

Flame tests can be used to distinguish metallic elements on the basis of flame colours; however, sometimes these colours are quite similar and the flame test is of limited value. The principles of flame testing have been used to develop more sophisticated techniques such as **atomic emission spectroscopy**.

A sample of the material being tested is passed through a flame and the resulting emitted light is directed through a prism to separate it into a series of coloured lines called an **emission spectrum**. As with the flame test, the light is the result of the energy emitted as electrons go from an excited state back to a lower energy level. The emission spectrum is like a fingerprint, distinctive to individual elements. In atomic emission spectroscopy a hotter flame than a Bunsen burner is used—the hotter flame can excite the electrons of a larger range of elements.

**Atomic emission spectroscopy** measures concentration and identifies a metal element in a sample based on the emission spectrum.





**figure 14.1** The layout of an atomic emission spectrometer.

The energy levels of an element are unique to that element since they are the result of the number of protons in the nucleus and their attraction for the electrons. The resulting emission spectrum is specific to a particular element and can be used to accurately identify the elements in a substance.



Each line of an **emission spectrum** corresponds to a particular transition between energy levels.



**figure 14.2** (a) Calcium and (b) sodium and have distinctive emission spectra.

The heat of a flame has sufficient energy to excite the electrons of only a few elements and atomic emission spectroscopy is used mainly to identify metal elements of groups 1 and 2. Other methods for identifying elements and compounds have been developed and some will be described in the following sections of this chapter.

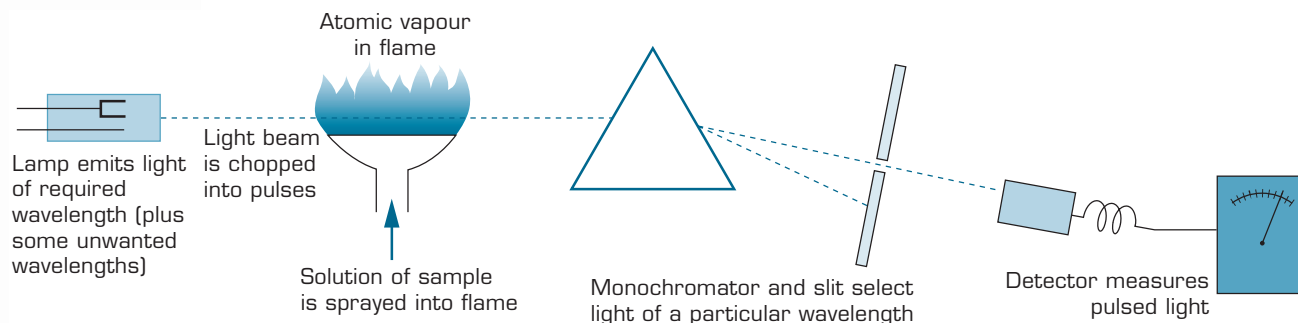
## Questions

- 1 Explain why atomic emission spectroscopy is regarded as a superior method of analysis to flame tests.
- 2 Why does an emission spectrum contain a number of lines of different colours?

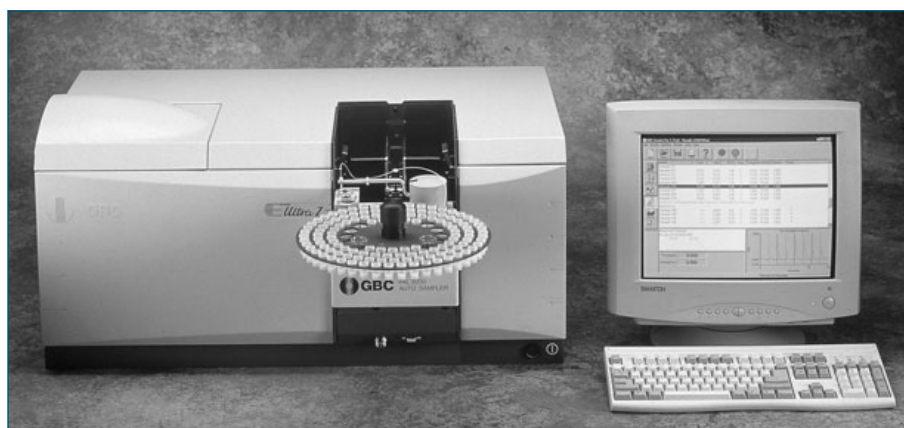
## 14.2 Atomic absorption spectroscopy

Atomic absorption spectroscopy was invented in the early 1950s by an Australian CSIRO scientist named Alan Walsh. He had been working on detecting small concentrations of metals using atomic emission spectroscopy when he had the idea of detecting the light absorbed by atoms rather than the light emitted.





**figure 14.3** The layout of an atomic absorption spectrometer.



**figure 14.4** Modern atomic absorption spectrometers are enhanced by computer technology which allows multiple samples to be analysed rapidly.

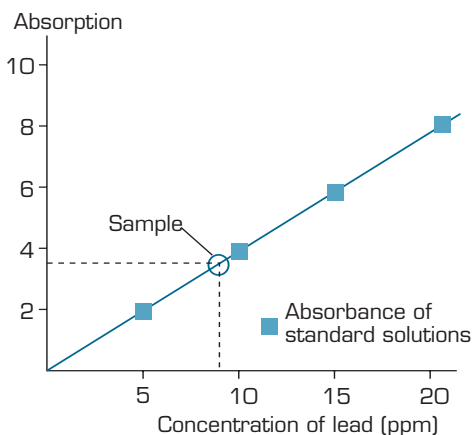
An **atomic absorption spectrometer** makes use of a beam of light of a specific wavelength passing through a flame. At the same time a sample solution is sprayed into the flame and vaporised. Electrons in atoms of the sample are promoted to higher energy levels as they absorb some of the energy of the light beam. The beam of light then passes through a **monochromator** which isolates light of the specific wavelength. The light then hits an electronic detector, which measures the intensity. The quantity of the element in the sample is proportional to the amount of light absorbed.

To determine the concentration of an unknown sample, samples of known concentration need to be prepared. The absorption by each known sample is measured and graphed (figure 14.5). By measuring the absorption of the unknown sample, the absorption graph can then be used to determine the concentration of the unknown sample.

**Atomic absorption spectroscopy** is superior to atomic emission spectroscopy in that it can be used to detect 68 different metals in solution and determine their concentrations down to levels of parts per billion (or even parts per trillion in some cases). It can be used for analysis of such things as the mercury content of fish and other seafood, the excess or deficiency of metals in urine or blood samples, and pollution levels in air, water and soil.

A monochromator is a prism that rotates allowing light of a single wavelength to be selected.

Parts per million (ppm) is a way of expressing concentration, i.e. grams per million grams.



**figure 14.5** This graph was constructed by measuring the absorption of solutions of known concentration.

## Questions

- 3 Atoms will emit as well as absorb light of a characteristic wavelength when they are sprayed into a flame. With reference to figure 14.3, explain how the emitted light is prevented from interfering with the absorption measurement.
- 4 Iron is essential to our health. To determine the iron content in a Milo milk drink, a 5.0 mL sample was diluted to 50.0 mL. The absorption of the diluted solution and of several standard solutions of known concentration were measured using atomic absorption spectroscopy. The results are shown in table 14.1.
  - a Plot a graph of absorption against concentration of iron.
  - b What is the concentration of iron, in ppm, in the diluted Milo?
  - c Calculate the concentration of iron, in ppm, in the undiluted Milo.
  - d What mass of iron would you consume by drinking a 250 mL glass of Milo?
  - e The recommended daily allowance (RDA) of iron for people over the age of 11 years is 18 mg. What percentage of your daily needs does a 250 mL glass of Milo provide?
  - f The 0.00 ppm standard, which contained no added iron, gave a small absorption reading. Suggest an explanation for this.
  - g Suggest why the sample of Milo was diluted in order to measure its absorption.

table 14.1

Solution concentration (ppm)	Absorption
0.00	0.010
1.00	0.080
2.00	0.150
3.00	0.220
4.00	0.290
sample	0.190

## 14.3 Colorimetry

In coloured solutions, the depth or darkness of the solution is an indication of its concentration. The less concentrated the solution, the lighter in colour the solution appears. In highly concentrated solutions, the colour appears deeper.

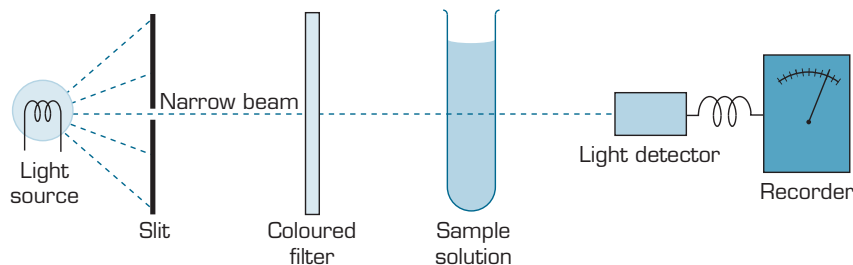
The colour of a solution is caused by absorption of light in the visible region of the spectrum. As with atomic emission spectroscopy, the colour of the solution is due to the transition of electrons between energy levels. A solution will absorb white light from the sun or an artificial source and allow light of a particular colour to pass through. The amount of light absorbed by a coloured solution is proportional to its concentration.



The colour of a solution is due to the light allowed to pass through the solution rather than the light absorbed.



An instrument called a **colorimeter** (figure 14.6) can be used to determine the concentration of a solution by the depth of its colour. In the colorimeter a beam of light passes through a sample of the solution and a detector is used to measure the intensity of the light after it has passed through. The light absorbed by samples of known concentration is used to construct a calibration graph. The concentration of solutions of unknown concentration can then be read off this graph using their absorption of light.



**figure 14.6** The construction of a colorimeter.

This technique can also be used on colourless solutions by first reacting them to produce solutions of coloured compounds.

**Colorimetry** is quite simple, inexpensive and capable of detecting a wide range of metal cations and some anions. While reasonably accurate (to within 1–2 per cent), other techniques such as atomic absorption spectroscopy are preferred over colorimetry as they are generally faster and more accurate.

## Worksheet 1

Comparing analytical techniques

## Experiment 14.1

### Colorimetric analysis of iron in foods

#### materials

- standard solutions containing 0.0050%, 0.0025%, 0.0013%, 0.0010% and 0.000 50% iron
- 2.5 g food sample, e.g. raisins, spinach, silver beet, parsley
- 5 mL of 0.1 M potassium thiocyanate solution
- 10 mL of 2 M hydrochloric acid
- 5 mL deionised water
- crucible
- funnel
- 100 mL beaker
- 100 mL conical flask
- 10 mL measuring cylinder
- semi-micro spatula
- filter paper
- test tube and stopper

#### Purpose

To analyse the iron content of a sample of food using a colorimetric technique.

#### Method

- 1 Weigh a sample of a food of about 2.5 g in a crucible. Record its exact mass.
- 2 Heat the crucible, without a lid, until the food has been completely reduced to ash. Gentle heating is necessary at first to prevent excessive fumes, spitting and consequent loss of mass.
- 3 When cool, transfer the ash to a 100 mL beaker and, using a measuring cylinder, add 10 mL of 2 M hydrochloric acid. Stir for 2–3 minutes.
- 4 Using the measuring cylinder, add 5 mL of deionised water to the beaker. Filter this solution into a 100 mL conical flask.
- 5 Using the measuring cylinder again, pour 5 mL of the filtrate into a test tube and add 5 mL of 0.1 M potassium thiocyanate solution. Stopper the test tube and shake once or twice to mix.
- 6 Compare the red colour of the solution in the test tube with the colours of the standard solutions provided by your teacher. It may be helpful to look at the colours against a white background and to look down the tubes when making your comparison. Estimate and record the concentration of iron in your solution.
- 7 If time permits, repeat this procedure with a sample of a different food.

## Use of colorimeter and electronic data collection equipment

A colorimeter (and electronic data collection device if available) can be used to improve the accuracy of this analysis.

Fill a cell to three-quarters of its volume with deionised water and wipe the outside of the cell with a tissue. By following the manufacturer's instructions, calibrate the colorimeter to read zero transmittance when no light passes through the cell and 100% transmittance when blue light (470 nm) passes through the cell. Use blue light for the remainder of this experiment.

Discard the liquid from the cell, rinse the cell twice with the 0.000 50% standard solution, and fill the cell to three-quarters of its volume. Measure the absorbance and record the results. In a similar fashion measure the absorbance of the other standard solutions.

Construct a graph of absorbance against concentration (using data collection software if possible). Since absorbance is directly proportional to concentration, draw a straight line of best fit through the data points and passing through the origin.

Measure the absorbance of the unknown solution and determine, from the graph, the concentration of iron in the unknown solution.

### Questions

- In this experiment, the iron in the ash from the food was dissolved in 15 mL of liquid (10 mL of hydrochloric acid and 5 mL of water). A 5 mL volume of this solution was then mixed with 5 mL of potassium thiocyanate and the absorbance measured.
  - What is the concentration of iron in the 15 mL of liquid, in  $\text{mg L}^{-1}$ ?
  - Assume the 15 mL of liquid weighs 15 g (i.e. the density is  $1.0 \text{ g mL}^{-1}$ ). Using your answer to part a, calculate the mass of iron in this volume of liquid. This is the mass of iron present in the 2.5 g food sample.
- Calculate the percentage by mass of iron in the food sample.
- Look up a book of food composition data to find the iron contents of various foods.
  - Compare the values you and other class members obtained in this experiment with those listed in the book. Suggest reasons for any discrepancies.
  - Name four foods that have a particularly high iron content.
- If this analysis was performed using a colorimeter, blue–green light would be used to measure the absorbance of solutions. Why is red light not used?

### materials

- test-tube rack
- stirring rod
- crucible tongs
- Bunsen burner, tripod stand and pipeclay triangle
- bench mat
- electronic balance
- book of food composition data
- colorimeter and data collection system if available

### safety

- Wear safety glasses and a laboratory coat for this experiment.
- Hydrochloric acid is corrosive.
- Potassium thiocyanate may cause irritation to the skin and eyes. Avoid contact.

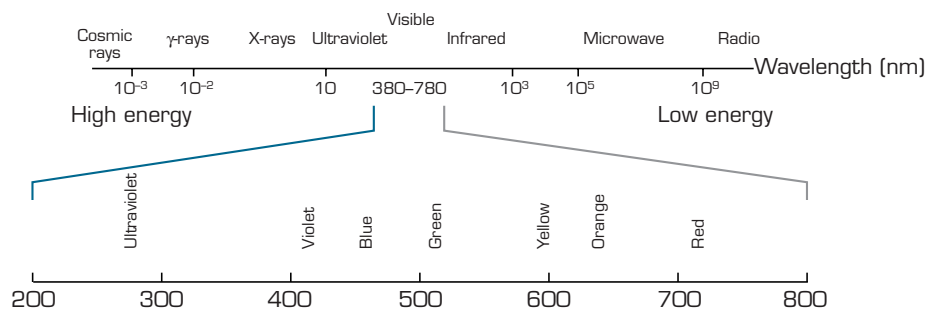
### Questions

- Two samples of copper sulfate solution, with concentrations of 0.080 M and 0.30 M, were analysed using a colorimeter.
  - Which sample concentration would allow most light to pass through to the detector?
  - Which sample concentration would show the strongest absorption of the light?
- Why would red light be used in a colorimeter to measure the concentration of a blue copper sulfate solution, rather than blue light?



## 14.4 UV-visible spectroscopy

The **electromagnetic spectrum** (figure 14.7) consists of several types of radiation. Radio waves have a long wavelength and are a low energy form of radiation; high energy cosmic rays have a very short wavelength. The section of the electromagnetic spectrum that the human eye can detect is known as the visible region.



**figure 14.7** The electromagnetic spectrum. Wavelength is measured in nanometres (nm).  $1 \text{ nm} = 10^{-9} \text{ m}$ .

An object appears coloured because it absorbs light of certain parts of the visible spectrum and the human eye detects the remaining or complement of the absorbed colour. An object may appear a certain shade of blue as it absorbs light from the yellow, orange and red regions of the visible spectrum. Table 14.2 shows some absorbed colours and their complementary (observed) colours.

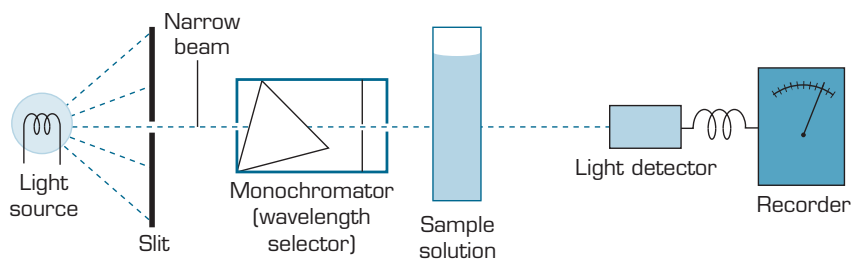
**table 14.2** Colours of visible light and complementary colours.

Wavelength (nm)	Colour absorbed	Colour observed
380–420	violet	green–yellow
420–440	violet–blue	yellow
440–470	blue	orange
470–500	blue–green	red
500–520	green	purple
520–550	yellow–green	violet
550–580	yellow	violet–blue
580–620	orange	blue
620–680	red	blue–green
680–780	purple	green

A **UV-visible spectrophotometer** (figure 14.8) detects absorption of not only visible light but also light from the ultraviolet part of the electromagnetic spectrum. The light source provides both UV and visible light. As the prism of the monochromator rotates, it allows light of particular wavelengths to pass through the sample. Over a period of time, light of various wavelengths pass through the sample and the intensity is measured by a light detector.

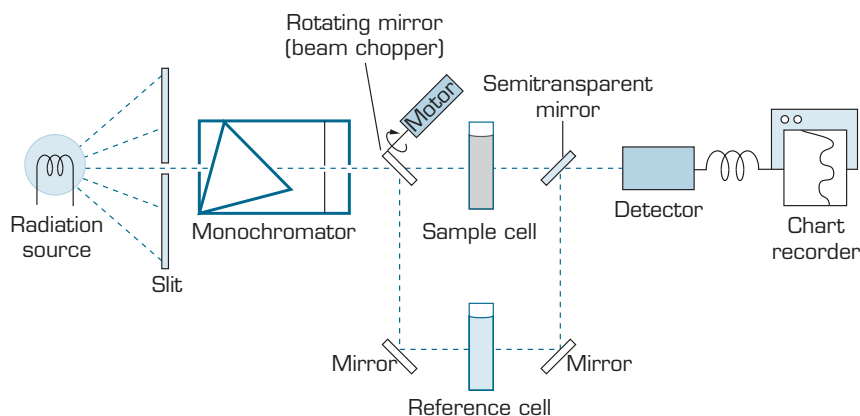
The electromagnetic spectrum is the range of radiation that extends from the low energy radio waves through to high energy cosmic rays.

**UV-visible spectroscopy** measures the absorption of light in the ultraviolet and visible regions. These measurements can be used to determine the identity and concentration of a sample.

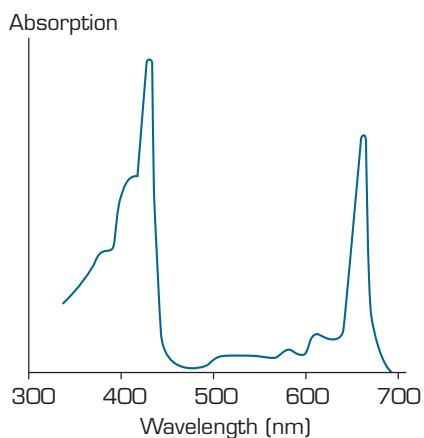


**figure 14.8** The construction of a UV-visible spectrophotometer.

It is not just the sample that absorbs UV-visible radiation; the solvent and the container used to hold the sample may also absorb some UV-visible radiation. Fused silica or quartz cells are used to hold the sample as both materials allow UV and visible light to pass through it easily. In simpler spectrophotometers, a cell containing only pure solvent, known as the reference cell, is used to take a reference reading before the sample is analysed. In modern spectrophotometers, the incoming beam is 'chopped' and alternately passed through reference and sample cells. This type of instrument is known as the **double beam scanning spectrophotometer** (figure 14.9). Both types of spectrophotometer give a graph or **spectrum** showing the absorption of light at various wavelengths for the sample alone (figure 14.10). The effects of the solvent have been deleted.



**figure 14.9** A double beam scanning spectrophotometer allows both sample and reference cells to be scanned simultaneously.



**figure 14.10** The UV-visible spectrum of chlorophyll shows that little light is absorbed in the 450–600 nm region of the spectrum. This is why chlorophyll appears green. The blue, green, yellow region is not absorbed.



The UV-visible spectrum of a substance is like a fingerprint of that substance. The electrons of its atoms, ions or molecules absorb energy as they are promoted from lower to higher energy levels. The energies of these transitions are determined by the electron configurations of individual atoms as well as the bonding and proximity of other atoms in a compound. The spectrum of each compound is unique to the substance and UV-visible spectroscopy can assist in the identification of unknown substances.

The concentration of a known sample can also be determined using this technique by selecting a wavelength at which the substance absorbs strongly and comparing it with the absorption of standard solutions of known concentration using a calibration graph.

The ultraviolet and visible regions of the electromagnetic spectrum consist of radiation of the correct wavelength (amount of energy) to excite electrons. Other regions of the electromagnetic spectrum may affect atoms and molecules differently. For example the bending and stretching of bonds involves energy of the infrared region and the rotation of molecules involves energy of the microwave region.

## Questions

- 7 The phosphate content of a detergent can be analysed using UV-visible spectroscopy. In one analysis, a 0.250 g sample of detergent powder was dissolved in water and the solution made up to 250 mL. The solution was treated with a small volume of sodium molybdate solution to form a blue solution. The absorbance of the solution at a wavelength of 600 nm was measured as 0.17. The absorbances of five standard phosphate solutions were measured in a similar fashion and the calibration graph in figure 14.11 was obtained.
- What is the concentration of phosphorus in the 250 mL detergent solution?
  - Determine the percentage by mass of phosphorus in the detergent powder.
  - Why was a wavelength of 600 nm selected for this analysis?

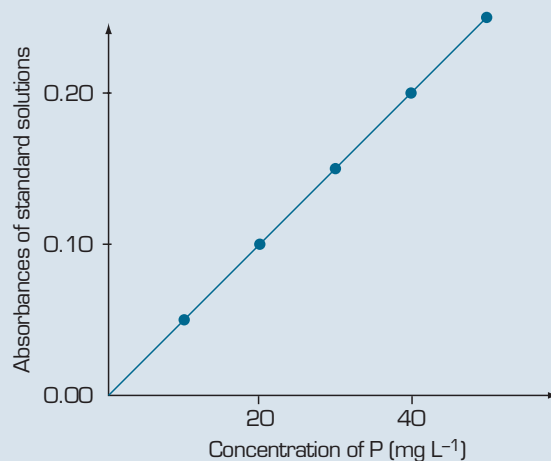


figure 14.11

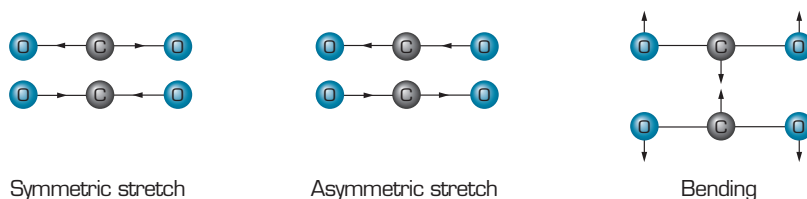
## 14.5 Infrared spectroscopy

**Infrared spectroscopy** is a form of molecular spectroscopy. It is concerned with the energy changes that take place as the vibrations within a molecule change. Diatomic molecules can only vibrate as their bonds stretch and shrink. Molecules with more than two atoms can also vibrate as they bend.

Just as energy levels exist for electrons, specific **vibrational energy levels** also exist. Molecular substances have discrete energy levels according to the types of vibrations their bonds can undertake. Movement between the vibrational energy levels of a molecule coincide with the absorption or emission of radiation in the frequency range  $10^{14}$ – $10^{13}$  Hz. This corresponds to the infrared region of the electromagnetic spectrum.

Molecular substances have discrete energy levels according to the types of vibrations their bonds can undertake.





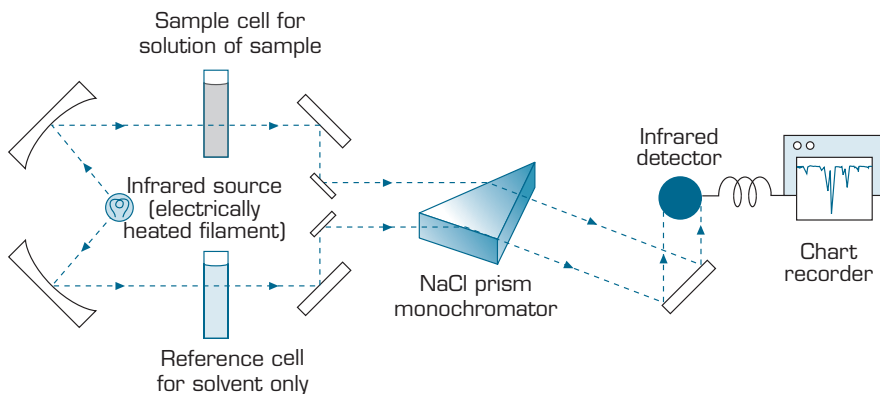
**figure 14.12** The stretching and bending vibrations of a carbon dioxide molecule.

In an infrared spectrometer (figure 14.13), radiation is produced by an electrically heated filament. Two beams are formed and one passes through a reference cell containing only solvent and the other passes through a sample cell containing some of the sample dissolved in the same solvent. The use of a reference cell cancels out any solvent absorption as well as absorption by water and carbon dioxide in the air. The monochromator consists of a prism of sodium chloride which allows infrared light to pass through unchanged.

As the monochromator rotates, light of different frequencies is directed onto the detector and their intensities measured. This system allows the final absorption recorded to be that of the sample alone. Absorption is recorded as molecules move to a higher vibrational energy level and the sample absorbs infrared radiation of a particular frequency.



**Infrared spectroscopy** measures the absorption of infrared radiation by molecules, and identifies the types of bonding and therefore the structure of the molecule.

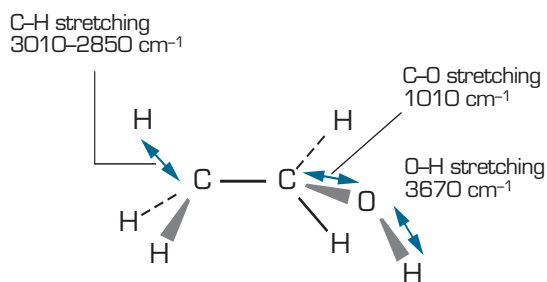
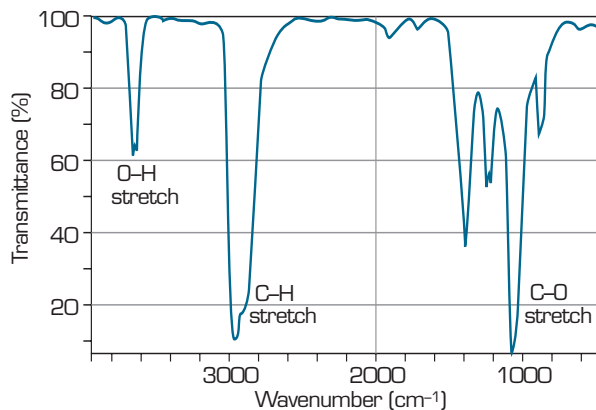


**figure 14.13** The construction of an infrared spectrometer.

Different types of bonds absorb infrared energy of different frequencies. The type of atoms present in a molecule can slightly alter the frequency for a particular bond type. A particular type of bond is said to have an absorption region rather than a specific frequency. Tables of these frequency ranges are used to identify a substance from its infrared spectrum.

The infrared spectrum of ethanol (figure 14.14) shows the peaks associated with the different bonds of the molecule. The chart appears to be upside down since it is a graph of **transmittance**. A transmittance of 100% means that infrared radiation of a particular frequency passes through unchanged. The absorption of radiation is recorded as a downward movement on the chart recorder.

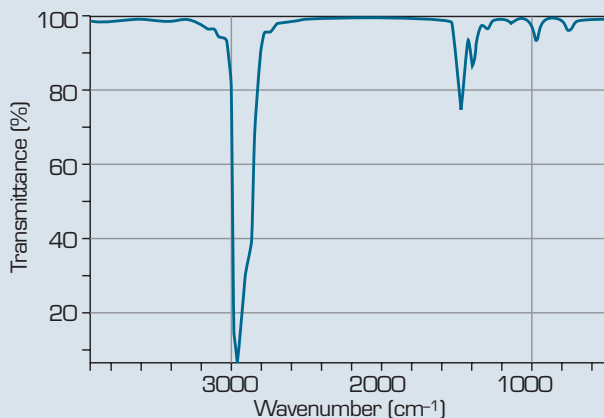
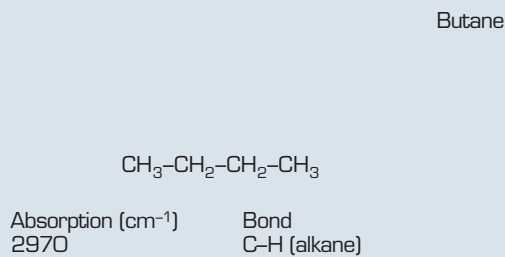




**figure 14.14** The various bond vibrations of ethanol and an infrared spectrum of gaseous ethanol.

## Questions

- Describe two ways in which infrared spectroscopy is similar to atomic absorption spectroscopy and three ways in which they are different.
- How do the possible vibrations of a water molecule ( $\text{H}_2\text{O}$ ) compare to those of hydrogen iodide ( $\text{HI}$ )?
- The infrared spectrum of butane ( $\text{C}_4\text{H}_{10}$ ) is shown in figure 14.15. Why is there only one main peak in this spectrum?



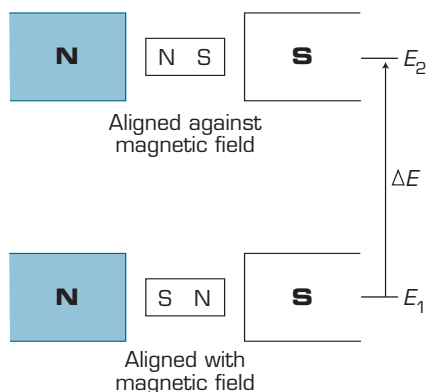
**figure 14.15**

## 14.6 Nuclear magnetic resonance spectroscopy

**Nuclear magnetic resonance spectroscopy (nmr)** can give information about the nuclei of certain atoms. It tells us about the environment around the particular nuclei (i.e. other atoms in the compound) and the number of nuclei of that type within the molecule.

Nmr can be used for  $^{13}\text{C}$ ,  $^{19}\text{F}$  and  $^{31}\text{P}$  nuclei but in this section we will focus on  $^1\text{H}$  nuclei. This technique is sometimes known as proton nmr since the nucleus of a hydrogen atom consists of one proton.

The nuclei of atoms generate a magnetic field. If they are placed in a strong, external magnetic field they will either align their own magnetic field with the external one or against it. Nuclei aligned with an external magnetic field exist at a lower energy level than those aligned against it. If the nuclei of the lower energy level are exposed to radiation of the correct frequency they will realign their magnetic field against the external one and move to a higher energy level.



**figure 14.16** A nucleus with its magnetic field aligned against an external magnetic field is at a higher energy level than a nucleus that is aligned with the field.

The magnetic field experienced by a nucleus is a combination of the applied magnetic field and the magnetic fields generated by other nuclei in the compound. Other nuclei generally oppose the external magnetic field partially cancelling it out and so the nucleus experiences a magnetic field slightly smaller than the one applied.

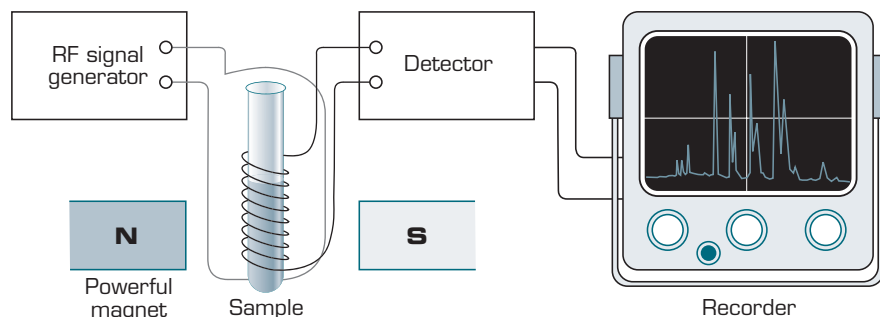
Hydrogen nuclei in different parts of a molecular compound, and those in different compounds, will experience different local magnetic fields. This can be measured by the amount of energy required to move a particular nuclei to a higher energy level.

The structure of a typical nmr spectrometer is shown in figure 14.17. The sample to be analysed is dissolved in  $\text{CD}_2\text{Cl}_2$  or  $\text{CD}_3\text{COCD}_3$ . These solvents have had their hydrogen atoms ( $^1\text{H}$ ) replaced with deuterium atoms ( $^2\text{H}$ , represented by D) so that they do not interfere with the spectrum of the sample. The sample is held in a spinning tube to ensure that the magnetic field it experiences is constant.



Nmr spectroscopy uses the interaction between the magnetic fields of atomic nuclei and an external magnetic fields to determine the molecular structure of a substance.



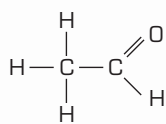


**figure 14.17** The construction of an nmr spectrometer.

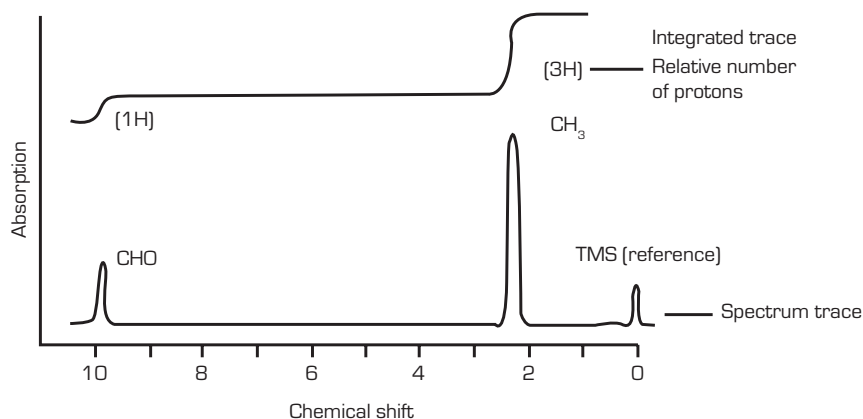
The radio frequency (RF) signal generator emits a pulsed band of radio frequencies causing the nuclei to move to a higher energy level. The nuclei almost immediately return to the lower energy level emitting a precise frequency that can be detected.

Ethanal (figure 14.18) has two types of hydrogen nuclei. There are three hydrogens attached to one carbon and the single hydrogen attached to a carbon which is also bonded to an oxygen atom. An nmr spectrum for ethanal (figure 14.19) shows the two peaks for the two different types of  $^1\text{H}$  nuclei.

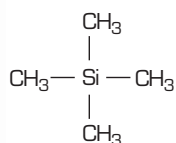
The integrated trace shows the area under each peak. The peak for the hydrogens of the  $\text{CH}_3$  group has three times the area of the peak for the hydrogen in the  $\text{CHO}$  group, indicating there are three times as many protons responsible for that peak.



**figure 14.18**  
Ethanal has hydrogen nuclei of two different environments.



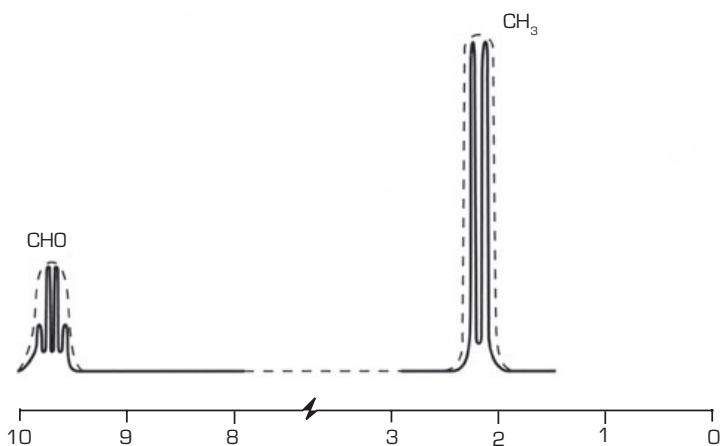
**figure 14.19** The low resolution nmr spectrum of ethanal features two main peaks.



**figure 14.20**  
Tetramethylsilane.

The peak labelled TMS is a reference peak. The substance tetramethylsilane (figure 14.20) gives a strong signal well away from most peaks generated by substances of interest to chemists. It is assigned a position of zero. The position of the signals for other types of protons relative to TMS is known as the **chemical shift**.

A higher resolution of the nmr spectrum of ethanal (figure 14.21) shows that each of the two peaks actually comprises smaller peaks. The three hydrogens of  $\text{CH}_3$  cause the  $^1\text{H}$  nucleus of the  $\text{CHO}$  group to generate four different peaks and the single hydrogen of the  $\text{CHO}$  group causes the  $^1\text{H}$  nuclei of the  $\text{CH}_3$  group to generate two different peaks.



**figure 14.21** The high resolution nmr spectrum (full lines) of ethanal compared to the low resolution spectrum (dotted lines).



The interaction between different  $^1\text{H}$  nuclei causes the spectrum to split. The reasons are too complicated for a full explanation here.

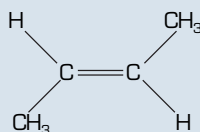
## Worksheet 2

Features of spectroscopic techniques

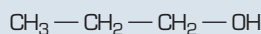
### Questions

- 11 What does the size of the peaks on an nmr spectrum indicate about a compound?
- 12 How many low resolution peaks would you expect for an nmr spectrum of these substances.

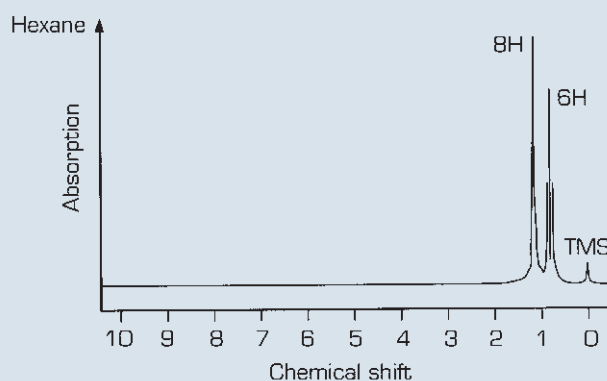
a but-2-ene



b 1-propanol



- 13 The nmr spectrum of hexane shows two main peaks (figure 14.22). Draw the structural formula of hexane and relate it to this spectrum.



**figure 14.22**

## 14.7 Chromatography techniques

**Chromatography** is a technique used to separate a mixture of substances into its individual components. Paper chromatography is one of the simplest forms of chromatography. There are several others described in this section. In all chromatographic methods there is a stationary phase and a mobile phase. The mobile phase moves through the stationary phase taking with it the components of the mixture being analysed. Individual components move at different rates as they **adsorb** onto the stationary phase and **desorb** back into the mobile phase according to the strength of attraction for each phase.



**Chromatography** is a technique used to separate the components of a mixture.



501

Instrumental and specialised techniques



The different methods are suited to different types of components and are designed to allow efficient separation and identification of these components. The techniques described below are paper chromatography, thin-layer chromatography, column chromatography, high performance (or high pressure) liquid chromatography and gas-liquid chromatography.

## Paper chromatography

**Mobile phase:** liquid solvent.

**Stationary phase:** paper

This technique is low cost and easy to set up. It is efficient for polar and water soluble compounds such as plant pigments and food dyes.

## Thin-layer chromatography

**Mobile phase:** liquid solvent

**Stationary phase:** a thin layer of fine powder (for example aluminium oxide or silica gel) on a plate of plastic or glass

This technique is faster and able to detect smaller amounts than paper chromatography. It gives a better separation of components that are less polar. It can be used with components that are corrosive.

Some mixtures include compounds that are colourless. For both paper chromatography and thin-layer chromatography, ultraviolet light can be used to make organic compounds fluoresce and hence visible. Some chromatograms are sprayed with chemicals which react with the components making them visible or causing them to fluoresce.

## Column chromatography

**Mobile phase:** liquid solvent

**Stationary phase:** powdered solid packed into a glass column. This solid may be coated with a viscous liquid.

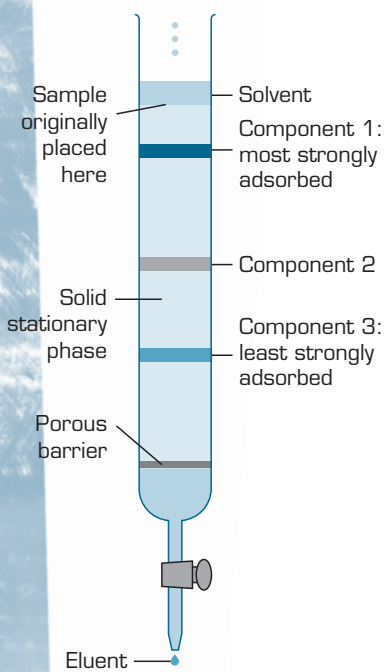
A sample is introduced at the top of the column into which a solvent is slowly dripped. The components move through at different rates creating lines in the column. The solvent leaving through the tap at the bottom is known as the eluent. This technique allows individual components to be collected for further testing.

## High performance liquid chromatography (HPLC)

**Mobile phase:** a liquid under high pressure

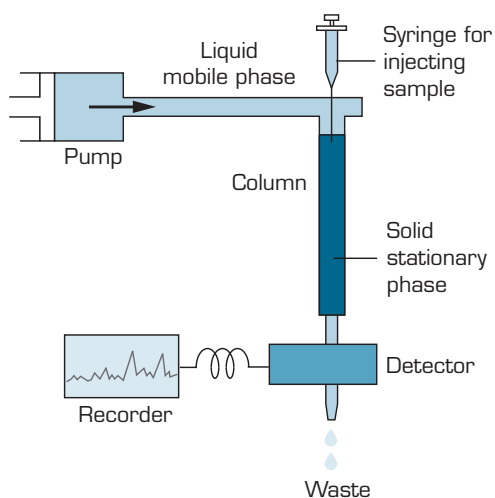
**Stationary phase:** solid powder packed into a column. A variety of solids can be used, some with particular compounds bonded to their surface. The particle size of the solids used are 10 to 20 times smaller than those used for column chromatography.

HPLC is similar to column chromatography; however, this method gives better separation. Since the particle size of the stationary phase is much smaller, the particles have a higher resistance to the flow of the liquid mobile phase. The sample is pumped through at a high pressure. Components are detected as the eluent passes UV light and their absorption of this light is measured by a detector. Retention time  $R_t$  is the time taken for a component to pass through the column.

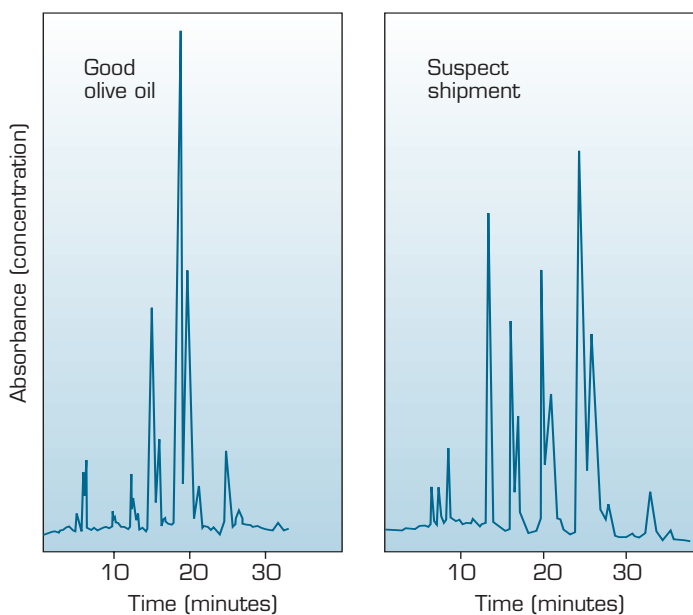


**figure 14.23**  
Column chromatograph.

A chart recorder is used to draw a chromatogram with a peak formed as each component passes through. The area under each peak indicates the relative amount of each component. This method can be used to separate compounds with a relative molecular masses of 1000 or greater.



**figure 14.24** High performance liquid chromatograph.



**figure 14.25** These two HPLC chromatograms are for a sample of olive oil and a shipment being passed off as olive oil. The suspect shipment contains many peaks that do not appear in the chromatogram for olive oil, indicating the presence of other substances.

## Gas-liquid chromatography (GLC)

**Mobile phase:** a carrier gas, generally nitrogen

**Stationary phase:** this technique uses a liquid stationary phase. It is a hydrocarbon or ester of high boiling temperature coated onto a porous solid and packed into a coil of glass tubing 2–3 metres long and about 4 mm in diameter. This column is mounted and heated in an oven.

GLC is restricted to compounds that can be vaporised without decomposing and generally have a relative molecular mass of 300 or less. It is capable of detecting amounts as small as  $10^{-12}$  g.



The sample mixture is injected into the heated injection port and immediately vaporised and carried into the column by the carrier gas. The components pass in and out of solution as they are adsorbed onto the liquid stationary phase and then vaporised back into the mobile phase. The most soluble components move slowest through the column and the least soluble are detected first. The retention time of the components is recorded using a chart recorder, resulting in a chromatogram similar to that for HPLC.

This method is capable of detecting, for example, the minute amounts of performance enhancing drugs that may be found in the urine sample of an athlete.

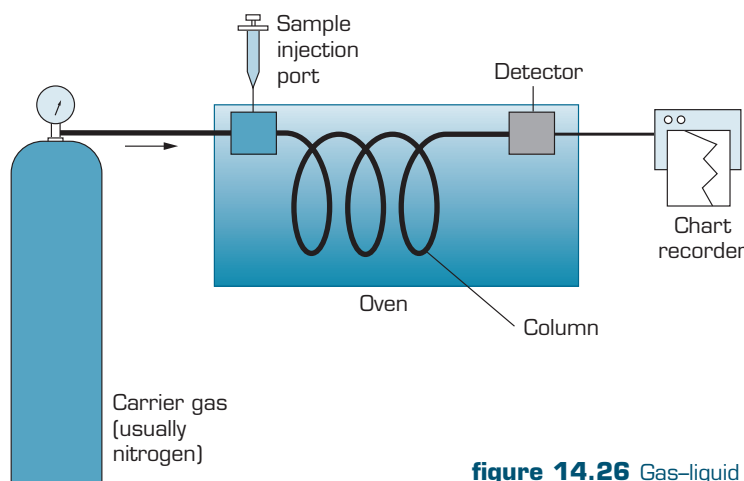


figure 14.26 Gas-liquid chromatograph.

## Electrophoresis

**Electrophoresis** is a technique developed from chromatography. The stationary phase consists of paper or a block of gel containing an electrolyte solution that enables it to conduct an electric current. Positive and negative electrodes are connected to opposite ends and any ions in the sample being tested will be attracted to the electrode of opposite charge. Different ions of the same charge will move at different rates according to their strengths of adsorption onto the stationary phase and desorption into the mobile phase, as well as the size of the ions and their relative charge.

Once the process is complete, the separated components are not always visible. One method of making them visible is to add radioactive isotopes that bind to the individual components. When exposed to a photographic plate the radiation released will produce spots on the developed plate. Another way of making components visible is to add a dye which binds to them. The technique used will depend on the nature of the components.

One of the most familiar areas in which electrophoresis is used is in DNA fingerprinting. This process allows a person to be matched to DNA found at a crime scene or to determine the likelihood of two people being related.

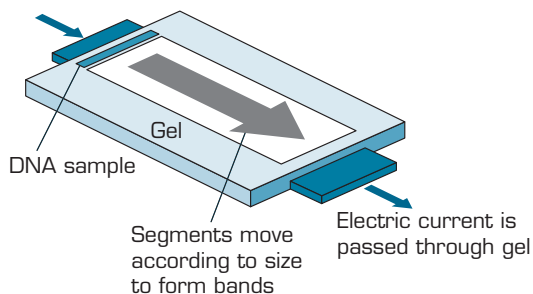


figure 14.27 Electrophoresis can be used to separate a DNA sample into specific segments.

Electrophoresis is a technique used to separate the components of a mixture according to their attraction for charged electrodes.

### Worksheet 3

Instrumental and specialised techniques



## Questions

- 14** There are several types of chromatography, including thin-layer and paper chromatography. What features are common to all types of chromatography?
- 15** Aspirin is a widely used drug in headache and cold preparations. Concentrations of organic compounds such as aspirin present in a formulation can be determined by a variety of methods, for example, paper chromatography, thin-layer chromatography, gas-liquid chromatography (GLC) or high performance liquid chromatography (HPLC). Final choice of a method of analysis involves consideration of the facilities available in the laboratory as well as problems inherent in each technique. Each of these techniques has its own limitations. Copy and complete table 14.3 to indicate which problem or problems (A–F) are associated with each technique. (Problems may be used more than once.)
- A** Difficult or impossible to get quantitative data.  
**B** Requires large amounts of solvent to operate.  
**C** Samples must be stable to heat.  
**D** Samples must be able to be dissolved in solvent.  
**E** Expensive equipment needed.  
**F** Samples cannot have a high molecular mass.
- 16** Electrophoresis has been described as similar in many ways to chromatography. Describe two ways in which it is similar and two ways in which it is different.

table 14.3

Technique	Problem(s) (give letter)
paper chromatography	
column chromatography	
thin-layer chromatography	
gas-liquid chromatography	
high performance liquid chromatography	



## Summary ▶▶▶▶

- ▶ **Flame tests** can be used to identify the presence of some metals due to the characteristic colour produced as excited electrons return from an **excited state** back to a lower energy level. **Atomic emission spectroscopy** uses similar principles to flame tests but the flame colour is split by a prism into a series of lines known as an **emission spectrum**.
- ▶ **Atomic absorption spectroscopy** can be used to measure the concentration of a wide range of metal ions by measuring the amount of light they absorb as electrons are promoted from lower to higher energy levels.
- ▶ The concentration of a coloured solution can be determined by comparing the depth of its colour to that of solutions of known concentration in a technique known as **colorimetry**. A **colorimeter** is used to measure the absorption of light of a particular colour by sample solutions.
- ▶ **UV-visible spectroscopy** can be used to measure the absorption of ultraviolet and visible light by the electrons of compounds. The resulting absorption spectrum is unique to that compound and can assist in identifying unknown substances. The concentration of a compound can be determined by comparing its absorption of particular wavelengths with the absorption by samples of known concentration.
- ▶ **Infrared spectroscopy** measures the absorption of infrared radiation by molecules according to vibrational energy levels. This enables the types of bonding to be identified and therefore the structure of the molecule to be determined.
- ▶ **Nuclear magnetic resonance spectroscopy** uses the interaction between the magnetic fields of atomic nuclei and that of an external magnetic field to determine the molecular structure of a substance.
- ▶ Mixtures of substances can be separated by a range of chromatographic techniques. **Chromatography** always involves a **stationary phase** and a **mobile phase**. The mobile phase moves through the stationary phase taking with it the components of the mixture. Individual components **adsorb** onto the stationary phase and **desorb** into the mobile phase at different rates, causing these components to separate. **Electrophoresis** is a technique similar to chromatography, and is used to separate the components of a mixture according to their attraction for charged electrodes.

## Key terms ▶▶

atomic absorption spectroscopy

atomic emission spectroscopy

chromatography

colorimeter

colorimetry

desorb

electrophoresis

emission spectrum

excited state

flame tests

infrared spectroscopy

mobile phase

nuclear magnetic resonance spectroscopy

stationary phase

UV-visible spectroscopy



## Chapter Review

### 14.1 Atomic emission spectroscopy

- 17 A chemist used atomic emission spectroscopy to confirm the presence of calcium in a sample of soft drink. Atomic emission spectroscopy was used in preference to a flame test because:
- A atomic emission is cheaper than a flame test.
  - B atomic emission is quicker than a flame test.
  - C calcium salts do not produce a colour in a flame test.
  - D atomic emission can distinguish between metals that produce similar colours in a flame test.
- 18 Excited electrons lose energy by jumping from the shell they are in to a lower energy shell. Examine the spectrum of calcium in figure 14.2(a). Which line represents the electron jump of the largest energy? Explain.

### 14.2 Atomic absorption spectroscopy

- 19 The function of the flame in atomic absorption spectroscopy is to:
- I evaporate the sample solution.
  - II excite the metal atoms.
- A I
  - B II
  - C I and II

- 20 The function of the monochromator in atomic absorption spectroscopy is to:
- A separate the unwanted wavelengths of light emitted by the hollow cathode lamp.
  - B separate white light from the lamp into its component wavelengths.
  - C detect the light emitted by the hollow cathode lamp.
  - D detect the light emitted by the flame.
- 21 The Phoenix copper mine can produce copper at a profit if the average concentration of ore is 0.4% w/w copper or greater. The refined copper sells for US\$1600 per tonne. A 2.0 g sample of ore was ground, and the copper was dissolved in 10.0 mL aqua regia (a mixture of concentrated hydrochloric and nitric acids) and diluted to 200 mL with distilled water. Copper standards containing 2.0, 4.0, 6.0 and 12.0  $\mu\text{g mL}^{-1}$  copper were also prepared.

The calibration curve for the analysis of copper is shown in figure 14.28.

- a What was the concentration of copper in the sample solution?
- b What was the mass of copper in the 2.00 g sample of ore?
- c On the basis of the concentration in this sample, what mass of copper would be found in a tonne of ore? Is it commercially viable to extract the copper from this ore?
- d What would be the value of the copper extracted from a tonne of ore?

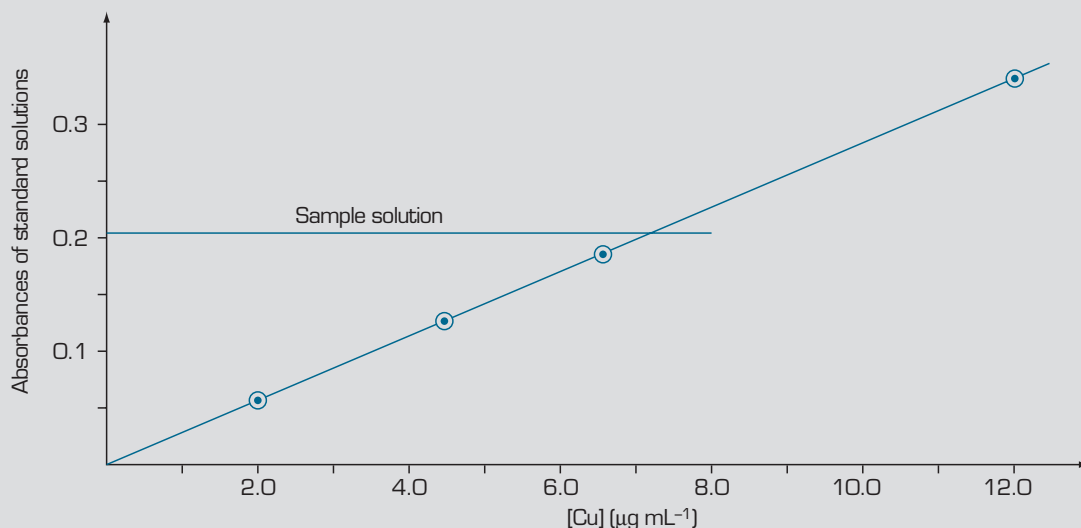


figure 14.28

- 22 The mineral cobaltite is mined for the production of cobalt. Ore containing cobaltite may also contain trace quantities of nickel. A sample of ore was analysed by atomic absorption spectroscopy to determine the concentration of nickel present. 5.0 g of the ore was dissolved in 25 mL concentrated nitric acid and then diluted to 100 mL. A concentrated stock solution containing 1000 ppm nickel was also prepared. 10 mL of the ore sample solution was pipetted into four 100 mL flasks and 1, 2, 4 and 6 mL of the concentrated stock nickel solution was added to the flasks. A standard addition calibration curve of standards 10, 20, 30 and 40 ppm added nickel was prepared, giving the following standards.

table 14.4

	Concentration of nickel (ppm)	Absorbance
standard 1	$x + 10$	0.25
standard 2	$x + 20$	0.34
standard 3	$x + 30$	0.44
standard 4	$x + 40$	0.53
sample	$x$	0.15

The absorbance readings for the standards and sample were determined by using light of wavelength 325.4 nm. The value of  $x$ , the concentration of nickel in ppm, was found from the intercept of the calibration curve with the  $x$ -axis at absorbance 0.

- Plot the absorbance values for the standards and sample on a graph. Insert a line of best fit through the points and determine the concentration of nickel in the sample solution.
- What mass of nickel was present in 5.0 g of ore?
- What is the percent by mass of nickel in the ore sample?
- Why is it preferable to use a standard addition calibration technique instead of preparing the standards in distilled water?
- Arsenic is present in cobaltite in concentrations equal to that of cobalt. Why does it not interfere in the calculation of the concentrations of cobalt or nickel?

### 14.3 Colorimetry

- 23 The technique of colorimetry is based on the theory that:
- emission of light is directly proportional to the concentration of the analyte in the cell.

- emission of light is directly proportional to the intensity of the coloured solution in the cell.
- absorption of light is directly proportional to the concentration of the coloured solution in the cell.
- absorption of light is directly proportional to the amount of analyte in the cell.

- 24 Atomic absorption spectroscopy (AAS) and colorimetry both involve absorption of light. Both can be used to determine the amount of copper in a solution.
- What species absorbs the light when copper nitrate is analysed by:
    - colorimetry?
    - AAS?
  - Which technique would be simplest for the analysis of 0.5 M copper nitrate solution? Explain your answer.
  - How is the light of the required wavelength selected in:
    - colorimetry?
    - AAS?

### 14.4 UV-visible spectroscopy

- 25 A sample was found to contain 44 ppm Cu by atomic absorption. This is equivalent to:
- $4.4 \mu\text{g mL}^{-1}$  Cu.
  - $44 \mu\text{g mL}^{-1}$  Cu.
  - $0.044 \text{ g L}^{-1}$  Cu.
  - $0.44 \text{ M}$  Cu.
- 26 The concentration of iron in a sample of dam water was determined by UV spectroscopy. Iron present as  $\text{Fe}^{2+}$  ions was reacted with a complexing agent to form the orange–yellow complex, iron(II) 1,10-phenanthroline. The absorbance of a series of standards and a sample of dam water is shown in table 14.5.

table 14.5

Concentration of $\text{Fe}^{2+}$ ( $\mu\text{g mL}^{-1}$ )	Absorbance
sample	0.38
4.0	0.16
8.0	0.31
12.0	0.42
16.0	0.63

Construct a calibration curve and determine the concentration of iron in ppm in the dam water.

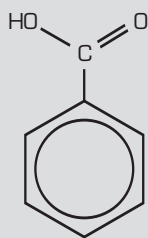
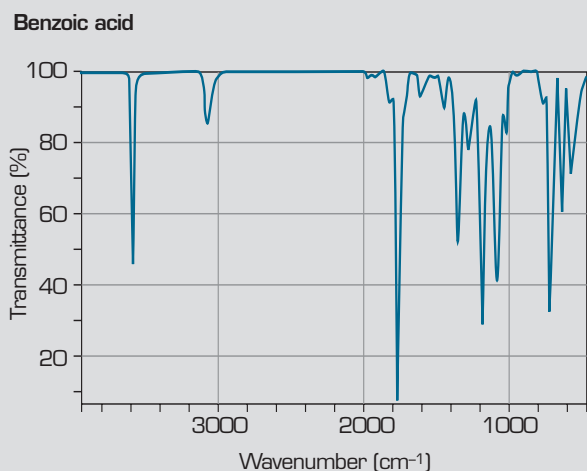
## 14.5 Infrared spectroscopy

- 27 What properties of a substance are associated with energy from the infrared region of the electromagnetic spectrum?
- 28 Why wouldn't you use infrared spectroscopy to analyse a sample for  $\text{Cu}^{2+}$  ions?
- 29 The typical regions of absorption of certain bond types in the infrared spectrum are shown in figure 14.29.

The region below  $1500\text{ cm}^{-1}$  is quite complex. It is difficult to assign peaks to individual bonds in this region. Chemists call it the fingerprint region because it can be used to compare two samples to determine whether they are the same compound.

Why is the fingerprint region so complex?

- 30 The infrared spectrum of benzoic acid is shown in figure 14.30.



Absorption ( $\text{cm}^{-1}$ )	Bond
3580	O-H
3080	C-H
1760	C=O

figure 14.30

Use the information in this diagram and figure 14.29 in Question 29 to answer the following questions for the infrared spectrum of phenol (figure 14.31).

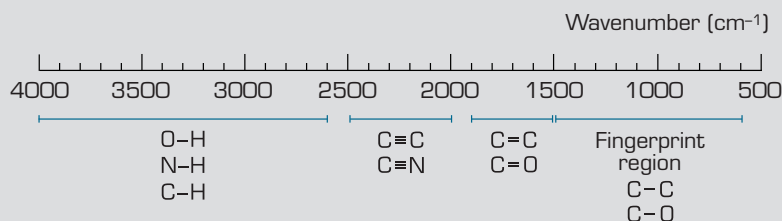


figure 14.29

- Identify the bond resulting in the peak on the far left.
- Which bond absorbs at  $3000\text{ cm}^{-1}$ ?
- Why is the region from  $1800\text{ cm}^{-1}$  and below so complex?

## 14.6 Nuclear magnetic resonance spectroscopy

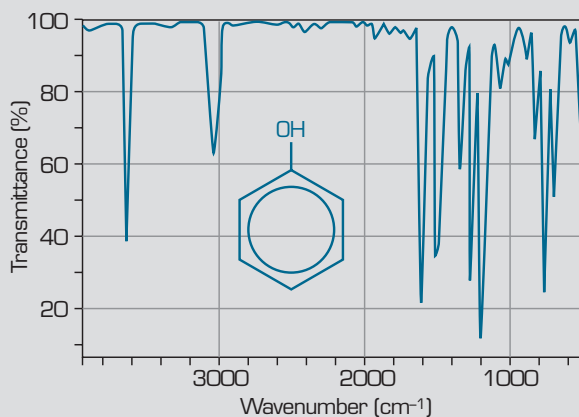
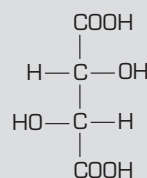
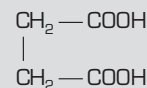


figure 14.31

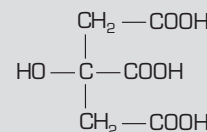
- 31 How many signals would you expect for the nmr spectrum of the following compounds commonly found in wine? (See figure 14.32.)



Tartaric acid



Succinic acid



Citric acid

figure 14.32

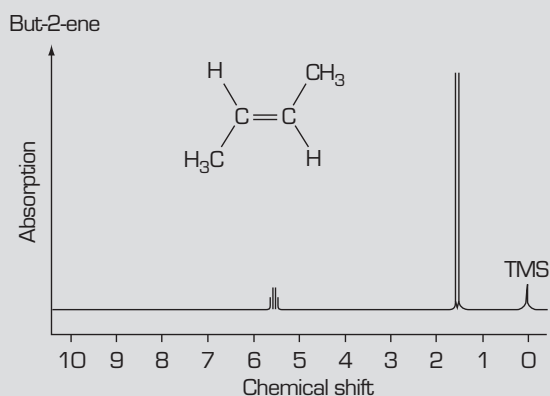


figure 14.33

32 The nmr spectrum of but-2-ene (figure 14.33) shows a small set of peaks and a large set of peaks. Explain which  $^1\text{H}$  nuclei of the molecule are associated with each set of peaks.

## 14.7 Chromatography techniques

33 The concentration of a substance is most accurately determined in HPLC by measuring:

- A peak area.
- B peak height.
- C retention time.
- D  $R_f$  value.

34 In gas-liquid chromatography the liquid stationary phase is coated on very small particles of solid silica or alumina. Small particles are used in preference to large particles to:

- A make the flow of gas through the column easier.
- B reduce the overall mass of the column.
- C increase the surface area of the liquid phase available.
- D make it easier to fill the column.

35 The stationary phase in chromatography can be:

- I solid.
- II liquid.
- III gas.

- A I
- B II
- C I or II
- D I, II or III

36 The retention time can be used in gas chromatography to determine:

- A the identity of a chemical.
- B the concentration of a chemical.
- C the amount of the chemical in the sample.
- D all of the above.

37 Chromatographic analysis of an unknown sample of an angina preparation containing nitroglycerine resulted in a narrow peak of height 25.3 cm. A standard solution containing  $9.5 \mu\text{g mL}^{-1}$  nitroglycerine gives a narrow peak of 10.5 cm. What is the concentration of nitroglycerine in the sample?

- A  $23 \mu\text{g mL}^{-1}$
- B  $27 \mu\text{g mL}^{-1}$
- C Cannot be determined as peak area is the only acceptable measure of concentration.
- D Cannot be determined as a range of standards must be tested to determine concentration.

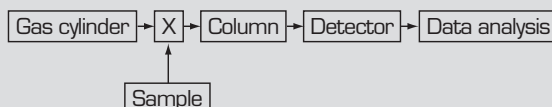


figure 14.34

38 Figure 14.34 shows a schematic for a gas-liquid chromatograph with one part labelled 'X'.

X is a:

- A heated injection port.
- B monochromator.
- C pump.
- D wavelength selector.

39 All forms of chromatography involve:

- A separation of the components of the mixture.
- B a solid stationary phase.
- C a solvent that carries the compound along.
- D a detector.

40 A herbal tea extract was analysed using HPLC. The chromatogram obtained is shown in figure 14.35.

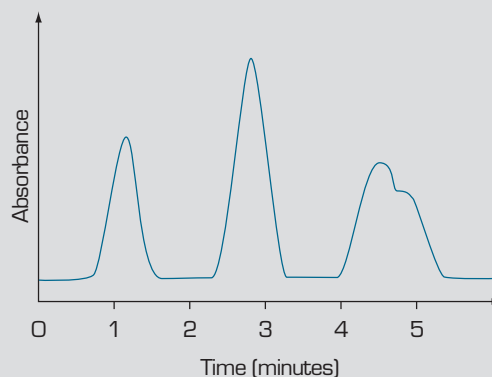


figure 14.35

- a Explain what information chemists can obtain from this chromatogram.
- b How many components are evident?
- c Briefly explain how the components are separated by the HPLC technique.

**41** A sample of an energy drink High-caff was analysed for the concentration of caffeine it contained. Details on the pack indicated that it should contain 12 mg caffeine per 100 mL. A chemist decided to analyse a sample of the drink, without dilution, by HPLC. 100 mL of 10.0 mg mL<sup>-1</sup> stock standard solution of caffeine was prepared from pure caffeine tablets. The chemist decided to prepare standards of the following concentration: 5, 10 and 20 mg caffeine per 100 mL. Available were 10 and 20 mL pipettes and 100 and 200 mL volumetric flasks.

- Describe the dilutions the chemist would need to make in order to prepare the standard solutions with the equipment available.
- The chemist could have used a 1 mL pipette and 100 mL volumetric flask to obtain a 10 mg per 100 mL standard from the stock solution with only one dilution. Why is this a less accurate method?

**42** A mixture of four alkanes (decane, heptane, hexane and octane) was separated by GLC. The solubility of the hydrocarbons in the liquid phase on the column was directly proportional to the relative molecular mass of the alkane. The chromatogram of the four hydrocarbons is shown in figure 14.36.

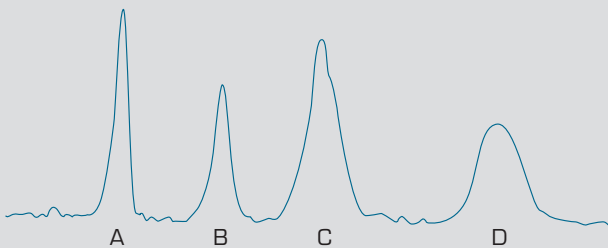


figure 14.36

- Identify the hydrocarbons A, B, C and D.
  - Why does decreased solubility of a chemical in the stationary phase decrease the retention time?
  - Why do the peaks become broader with increased retention time?
  - List the factors that can increase the retention time of a particular chemical in GLC.
- 43** The organic compounds dimethyl ether and ethanol have the same molecular formula, C<sub>2</sub>H<sub>6</sub>O, and molar mass. However, they have different structural formulae (see figure 14.37).

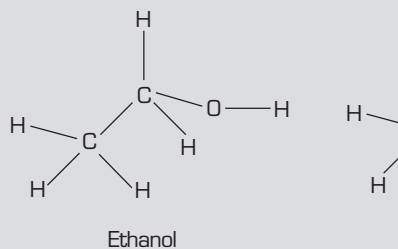


figure 14.37

A sample containing both ethanol and dimethyl ether is analysed by GLC using a nitrogen-specific detector (FID).

- Will the two compounds produce peaks at the same retention time? Explain your answer.
  - If the sample has the same peak area for both chemicals, will the peak heights be the same? Explain your answer.
- 44** Various forms of heart disease are very successfully treated with nitroglycerine patches. The small colourless patches are stuck to the skin and slowly release nitroglycerine into the blood at a rate of 0.4 mg per hour. A patch containing 10 mg of nitroglycerine in the patches controlled to prevent an overdose.

A nitroglycerine patch was dissolved in approximately 20 µL ethanol and diluted to 100 mL. 10.0 mL of this solution was diluted to 100 mL with water. 20 µL of the diluted sample and 20 µL of each of the standards of nitroglycerine were analysed on a 1.5 m GLC column and analysed using a nitrogen-specific detector.

table 14.6

Nitroglycerine standards	Peak area
standard 5 µg mL <sup>-1</sup>	7.2
standard 10 µg mL <sup>-1</sup>	14.4
standard 15 µg mL <sup>-1</sup>	22.2
diluted sample solution	10.0

- Construct a calibration curve and determine the concentration of nitroglycerine in the diluted sample.
- What mass of nitroglycerine was released by the patch?
- The patch has a total mass of 0.5 g. What is the percentage concentration (w/w) of nitroglycerine in the patch?

**45** The organophosphorus insecticide parathion has been widely used in mosquito-prone areas. An empty drum of the insecticide was found close to a major reservoir. The EPA was asked to analyse the water to determine whether it was fit for human consumption. Levels of parathion above  $0.01 \text{ mg L}^{-1}$  in water are a threat to human health. Parathion has an  $\text{LD}_{50}$  value (lethal dose to 50% of test animals exposed to this concentration) of  $8 \text{ mg kg}^{-1}$ .

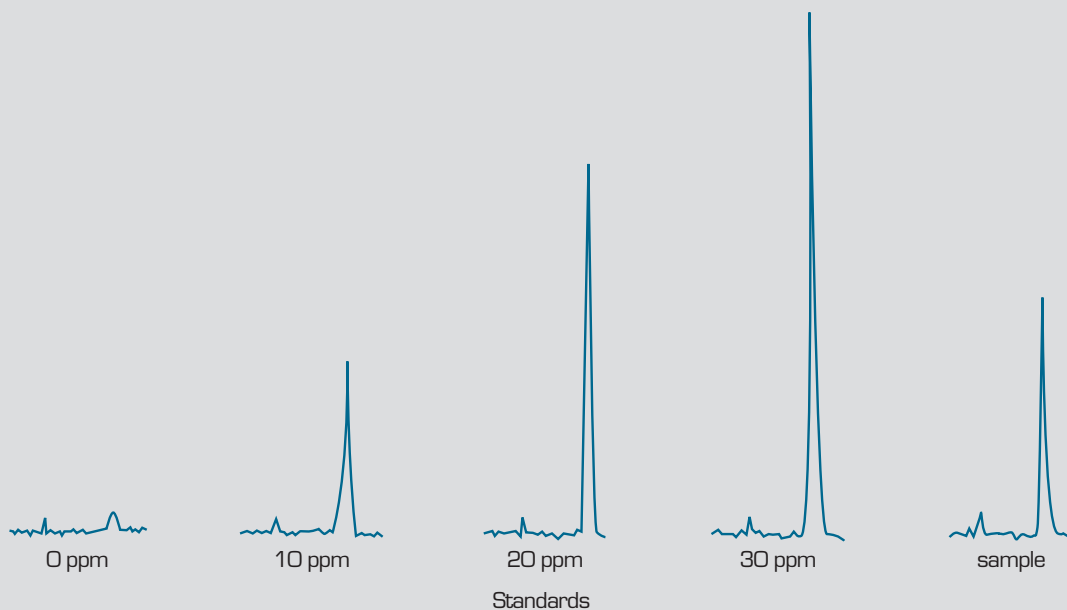
Parathion standards in water of 0, 10, 20 and 30 ppm parathion were prepared and analysed by HPLC. An undiluted sample of the water was run on the column under the same conditions. The chromatograms produced for the suspected contaminated water sample and parathion standards are shown in the figure 14.38.

- Copy and complete the table.
- Construct a calibration curve for the analysis of parathion.

**table 14.7**

Standard	Peak height (cm)
standard 0 ppm parathion	
standard 10 ppm parathion	
standard 20 ppm parathion	
standard 30 ppm parathion	
suspected contaminated water	

- Determine the concentration of parathion in the water sample.
- Is the dam water within the legal limits for safe drinking? Demonstrate your answer with a calculation.
- What volume of water would a laboratory mouse, mass 150 g, need to drink to reach the  $\text{LD}_{50}$  dose?
- Give possible reasons to explain the small peak observed with the 0 ppm standard of parathion.



**figure 14.38**

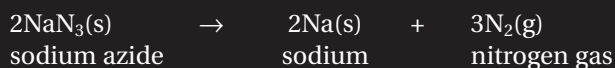


# 15

## Reaction rates

Chemical reactions are occurring all over the universe. Some are incredibly fast taking only fractions of a second to occur and others can be incredibly slow, taking years to complete.

Most reactions take only seconds. The rate of the reaction can be determined either by the time it takes for the reactants to be used up, or for the time it takes for products of the reaction to be formed. One of the chemical reactions that proceeds very quickly is the decomposition of sodium azide. It is one of the chemicals used in car airbags.



130 g sodium azide will produce 67 L of nitrogen and the reaction will take only 30 milliseconds to go to completion. The occupant of a car will take approximately 50 milliseconds to hit the dashboard after a crash.



**figure 15.1** The chemical reaction that inflates vehicle air bags must occur in milliseconds.

Controlling the rates of reactions is essential for industry. The faster the reaction, the more product can be produced in a given amount of time, which leads to bigger profits. The production of plastics, metals and fertilisers relies heavily on the ability to control and understand the rate of reactions. Even the thousands of reactions that occur in the human body are carefully controlled chemical reactions.

Exploring what makes a reaction go faster or slower, and the chemistry behind it, is the focus of this chapter.

## 15.1 Reaction speed

### Collision theory

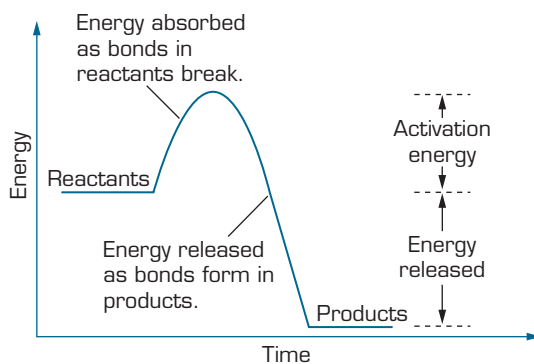
To properly understand what determines the speed of a reaction, you need to have a good understanding of **collision theory**.

For most chemical reactions to occur, substances must join or swap atoms with other atoms in another molecule or compound. There must be a collision between these particles, and the collision must have the right orientation and enough energy to break bonds and form new products. If reacting particles collide with insufficient energy or are oriented in the wrong way, the collision will not result in the formation of new products. The energy barrier that reacting particles must overcome is called the **activation energy**.

If the activation energy for a particular reaction is very small, then we could expect the reaction to proceed very quickly. If the activation energy for a reaction is very large then the reaction will not proceed until the reacting particles can collide with enough force to achieve activation energy.

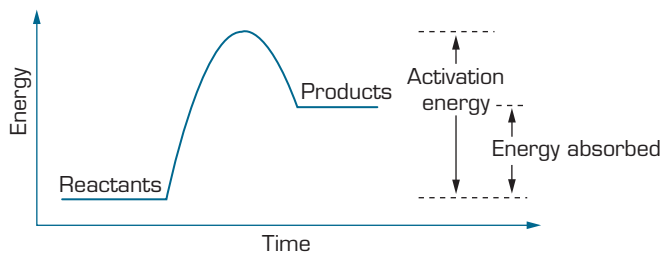
**Energy profile diagrams** can be used to illustrate the changes in energy that occur as reacting particles collide to form new products.

Exothermic reactions always result with the reactants releasing energy to form new products (see figure 15.2).



**figure 15.2** This diagram shows what happens when the activation energy is achieved during an exothermic reaction.

Endothermic reactions always result in the reactants absorbing energy to form new products (see figure 15.3).



**figure 15.3** This diagram shows what happens when the activation energy is achieved during an endothermic reaction.

**Collision theory** is a model that describes how the rate of a chemical reaction is determined by the collisions between reacting particles.

**Activation energy** is the minimum energy required for a collision between reacting particles to result in new products.

**Energy profile diagrams** depict the energy changes that occur during the course of a reaction.

The speed of a chemical reaction can be influenced by four factors:

- temperature
- concentration
- surface area
- action of a catalyst.

Thus, the result will be a greater number of collisions exceeding the activation energy, increasing the chances of successful collisions and therefore a faster reaction.

## Temperature

An increase in the temperature of a reacting mixture will increase the kinetic energy of reacting particles, leading to more collisions with greater energy. The result will be a greater number of collisions exceeding the activation energy, increasing the chances of successful collisions, and therefore a faster reaction.

Lowering the temperature of a reacting mixture will reduce the energy of reacting particles, resulting in fewer collisions with less energy and therefore a slower reaction.

increase temperature → increase kinetic energy → increases collisions → increases reaction rate

decrease temperature → decrease kinetic energy → decreases collisions → decrease reaction rate



**figure 15.4** Lowering the temperature of food slows down the reactions that cause food spoilage.

## Concentration

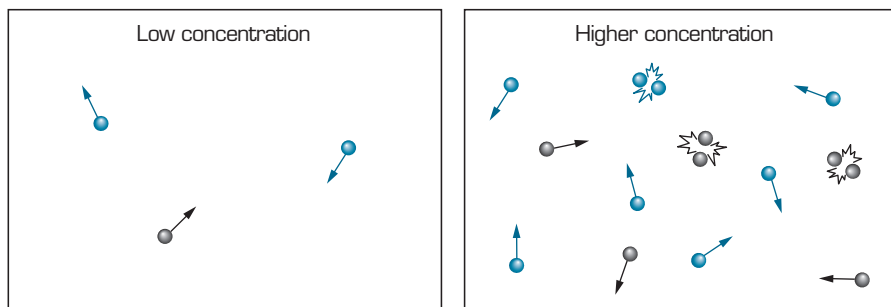
Increasing the concentration of a solution will increase the number of reacting particles in a given volume. There will be a greater likelihood of collisions that result in the formation of products, and therefore the reaction will be faster.

When reactions involve gases, increasing the pressure inside the reacting chamber will have the same effect as increasing the concentration. Lowering the pressure will slow the reaction due to fewer collisions.

increase concentration → increases number of collisions → increases rate of reaction

decrease concentration → decreases number of collisions → decreases rate of reaction





**figure 15.5** When there are more particles in the same volume then the number of collisions increases.

## Surface area

By increasing the surface area of any solids involved in a chemical reaction, you can increase the speed of the reaction. When a solid substance is broken into smaller pieces it provides a larger surface area over which collisions can occur. This results in a greater number of particles involved in collisions having sufficient energy for reaction. It increases the likelihood that these collisions will result in the formation of products, and therefore a faster reaction occurs.

increase surface area → increases number of collisions  
→ increases rate of reaction

decrease surface area → decreases number of collisions  
→ decreases rate of reaction

## Experiment 15.1 Dust explosion

*A rubber hose is inserted in the base of a can. A small quantity of powder is placed in the can, together with a lighted candle. The lid is then fitted on to the can. The teacher pumps air down the rubber hose, causing a loud explosion that forces the lid off the can.*

### Purpose

- 1 To show the effect of surface area on reaction rate.
- 2 To explain the cause of some coal mine and flour mill explosions.

### Method

#### Prior to the demonstration:

- 1 Drill a hole in the bottom of the can. Pass the rubber hose through the hole and connect it to the plastic funnel inside the can.

#### For the demonstration:

- 2 Show the contents of the can to the students.
- 3 Fit the free end of the rubber hose to an air pump.
- 4 Stand the can firmly on a tripod stand. Using plasticine, place a candle near the funnel.
- 5 Line the funnel with a small piece of tissue paper and carefully add a teaspoonful of lycopodium powder, as shown in figure 15.6.



- 6 Light the candle using the wax taper and dim the room lights. Fit the lid firmly and rapidly press on the air pump to force air through the rubber hose to disperse the powder inside the container.

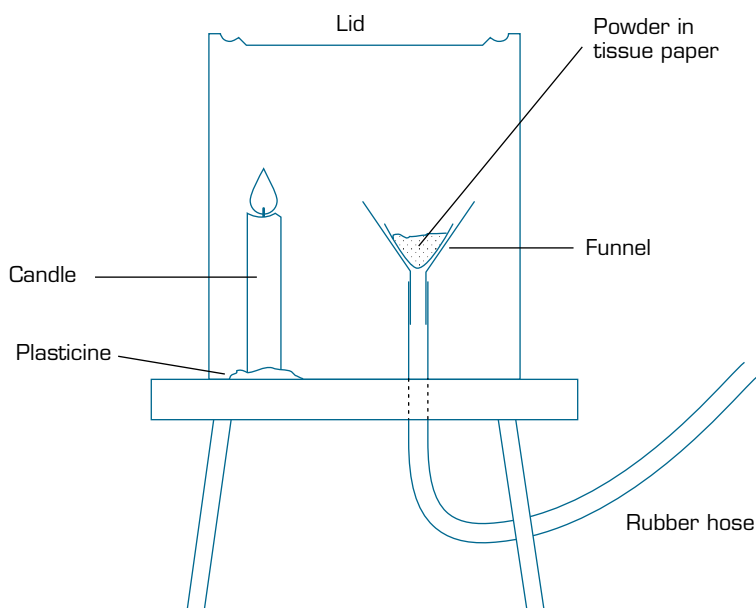


Figure 15.6

### Theory

The lycopodium powder is obtained from club moss spores and is composed of compounds containing carbon and hydrogen, which undergo combustion to produce carbon dioxide and steam. Since the reaction occurs in an enclosed space, the gases produced cause the pressure within the container to increase, blowing the lid off the can.

In this demonstration, the rate of reaction is enhanced by:

- the high surface area of the finely ground powder dispersed in the air. This increases the frequency of collisions between oxygen molecules in the air and the powder
- provision of sufficient energy (from the candle) to overcome the activation energy barrier of the reaction.

### Discussion

- 1 What causes the can to blow its top?
- 2 What type of reaction took place inside the container?
- 3 If the lycopodium powder contains carbon and hydrogen, suggest products of the reaction.
- 4 What factors increase the rate of reaction inside the container?
- 5 Why is it dangerous to smoke in a flour silo or a coal mine?

### materials

- teaspoonful of lycopodium powder (or dry corn flour)
- can with large, tight-fitting friction lid
- funnel with a 1 m rubber hose attached to the stem
- candle
- plasticine
- tissue paper
- tripod
- wax taper
- small foot- or hand-operated air pump
- matches

### safety

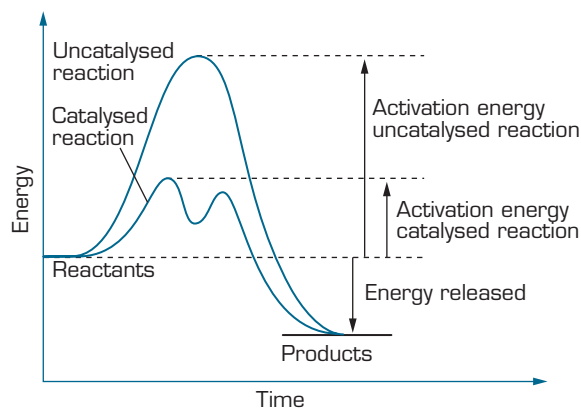
- Wear safety glasses and a laboratory coat for this demonstration.
- Use of a safety screen is recommended.
- Ensure that your head is well away from the top of the can when forcing air into the can, and that the propelled can lid will cause no damage to objects above it.



**Catalysts** are substances that speed up a chemical reaction without being consumed.

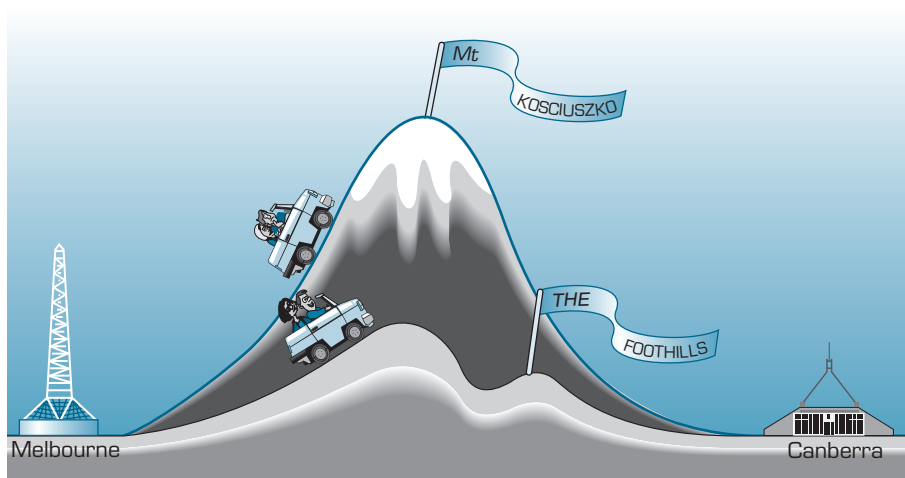
## Catalysts

Catalysts are substances that can be extremely effective in speeding up specific chemical reactions when added to the reaction mixture. Catalysts act by providing an alternative reaction pathway that has a lower activation energy than the original reaction. This means a larger number of reactant particles have sufficient energy to overcome the lower activation energy. This allows the formation of product(s) at a much faster rate. Catalysts do not alter the final product and are not used up by the reaction.



**figure 15.7** The energy profile diagram showing the pathway for catalysed and uncatalysed reactions.

Only small amounts of catalysts are usually needed to drastically increase the reaction rate. Some catalysts work by adsorbing the reactants onto its surface, weakening and sometimes breaking the bonds in reactant molecules and increasing their surface area. The increased surface area increases the number of collisions between reactants, and the weakened or broken bonds decrease the activation energy required for a collision to form new products. These two actions increase the rate of reaction.



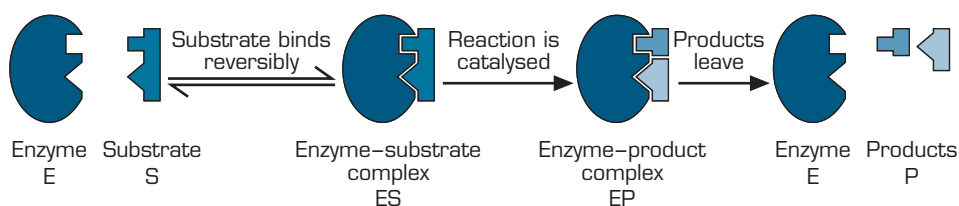
**figure 15.8** If Melbourne represents the reactants and Canberra the products, then the Mt Kosciuszko route represents the reaction pathway for an uncatalysed reaction. It takes longer and requires more energy. The foothills represent the reaction pathway for the catalysed reaction, which is faster and requires less energy.

Chemists classify catalysts as either homogeneous or heterogeneous. **Homogeneous catalysts** occur in the same physical state as the reacting particles. For example, if both the reacting particles and the catalyst were dissolved in aqueous solution then the catalyst would be defined as a homogeneous catalyst. Most biological catalysts (enzymes) are homogeneous catalysts.

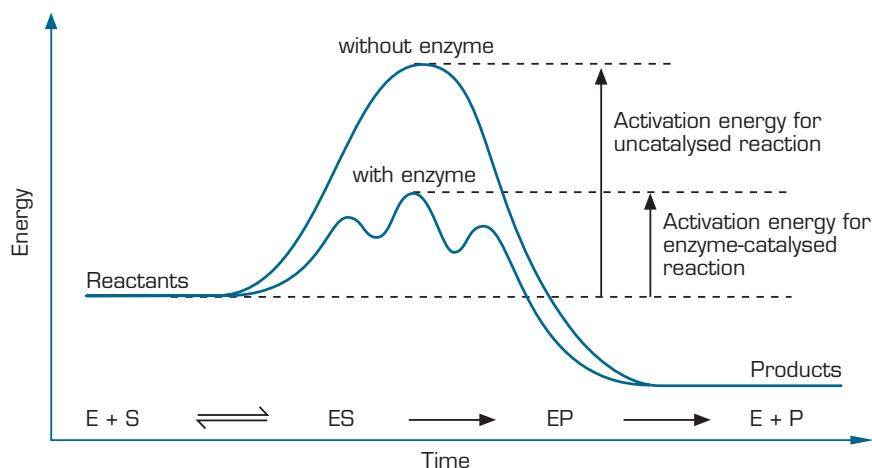
**Heterogeneous catalysts** are in a different state to the reacting particles. For example, a solid catalyst placed in a liquid reaction mixture would represent a heterogeneous catalyst. Most industrial reactions involve solid heterogeneous catalysts, which are easier to recover after the reaction. This is an important advantage in industry, as even a small quantity of certain catalysts can be very expensive. For example, the petroleum industry uses a very expensive metal catalyst (platinum) to produce high-octane petrol.

**Enzymes** are complex protein molecules that act as biological catalysts. They are highly specific and are very sensitive to changes in pH and temperature. Most of our body's reactions are catalysed by enzymes so that they will proceed fast enough for us to function normally.

Enzymes act by binding the **substrate** to its active site and causing it to react faster and form new products. When the reaction is complete the products don't bind as strongly to the site and are released to move elsewhere in the body. The action of enzymes and inorganic catalysts used by chemists is similar, but enzymes act much faster.



**figure 15.9** The diagram above shows the enzyme binding to the substrate weakening its bonds and then releasing the products once they have formed.



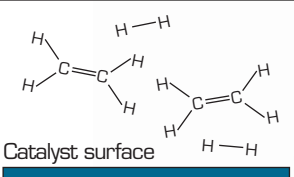
**figure 15.10** The energy profile diagram above illustrates the effect of the enzyme E. (S = substrate, P = product)

Substances called **inhibitors** can block enzyme action. Inhibitors are substances that interfere with an enzyme's ability to increase reaction rates. They act by binding to the active site of the enzyme and thereby affecting its ability to bind to the substrate.

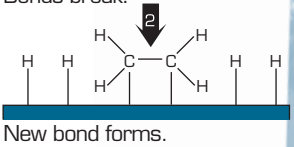
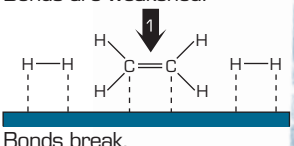
**Enzymes** are biological catalysts.

A **substrate** is a reactant molecule acted on by an enzyme to enable a chemical reaction to occur.

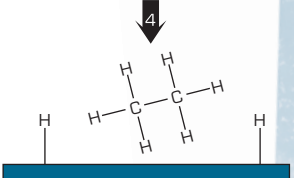
**Inhibitors** are substances that bind to the active site of an enzyme reducing its catalytic activity.



Reactants get adsorbed onto catalyst surface. Bonds are weakened.



Second bond forms, and product diffuses away from catalyst surface, leaving it free to absorb fresh reactants.



**figure 15.11** The action of a catalyst for the reaction between ethene and hydrogen.

**Worksheet 1**  
Factors that influence reaction rate



# Experiment 15.2

## Measuring the rate of reaction

### materials

- 40 mL of 2.0 M HCl
- 20 mL of 1.0 M HCl
- 40 g large marble chips
- 20 g small marble chips (Do not use powdered chips.)
- 3 × 100 mL conical flasks
- 100 mL measuring cylinder
- 50 mL beaker
- cotton wool
- electronic balance
- stopwatch
- computer and spreadsheet program (optional)

### safety

- Wear safety glasses and a laboratory coat for this experiment.

### Purpose

To measure the rate of the reaction between calcium carbonate and hydrochloric acid solution and investigate the effect of surface area and concentration on the rate.

### Method

#### A. Measuring reaction rate

- 1 Using a measuring cylinder, pour 20 mL of 2.0 M HCl into a 50 mL beaker.
- 2 Weigh approximately 20 g of large marble chips into a 100 mL conical flask and loosely place a cotton wool plug in the neck of the flask.
- 3 Place the conical flask containing the marble chips on an electronic balance. Place the beaker of acid beside the flask on the balance pan and tare the balance so that it reads zero. Carefully and quickly remove the cotton wool plug, add the acid to the flask, replace the beaker on the balance pan beside the flask, and replace the plug. Immediately start a stopwatch.
- 4 Note the reading on the balance after 15 seconds, 30 seconds and at 30 second intervals thereafter. Continue for up to 10 minutes, until no further change in mass is observed.
- 5 Draw up a table to record the mass loss (from the total starting mass) and the time, in minutes, from the start of the reaction. This could be done using a spreadsheet or graphing package.
- 6 Plot a graph of the mass loss against time.

#### B. Effect of surface area

Repeat the experiment as described in Part A, but this time use approximately 20 g of marble chips that have been crushed into much smaller pieces. Plot the graph of this data on the same set of axes as the first experiment.

#### C. Effect of concentration

Repeat the experiment as described in Part A, but this time use 20 mL of 1.0 M HCl. Plot the graph of this data on the same set of axes as the first experiment.

### Theory

Marble chips are composed of the ionic compound calcium carbonate. When chips are added to a hydrochloric acid solution the reaction that occurs produces carbon dioxide gas. Provided that no liquid spray is able to leave the flask in which the reaction occurs, only carbon dioxide gas will be lost from the flask as the reaction proceeds. This is the equation for the reaction:



In this experiment the loss in mass of a conical flask and its contents during the reaction is monitored. The mass loss is equal to the mass of carbon dioxide that has been evolved in the reaction.

### Discussion

- 1 How is the graph of mass loss against time related to the rate of the reaction between calcium carbonate and hydrochloric acid?



- How is the rate of the reaction affected by decreasing the particle size of calcium carbonate? Explain this result in terms of the collision theory.
- How is the rate of the reaction affected by decreasing the concentration of the hydrochloric acid solution? Explain this result in terms of the collision theory.
- Is the maximum mass loss the same for all three experiments? How do you account for any differences?
- Suggest another experimental arrangement that could be used to monitor the rate of this reaction. Include a diagram to assist with your explanation.

## Experiment 15.3

### Foam column

*A colourless liquid and a detergent are put in a measuring cylinder and a small quantity of a white powder is added. A column of foam is formed, which rises up and overflows from the cylinder.*

#### Purpose

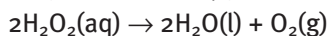
To show the effect of a catalyst on the rate of a chemical reaction.

#### Method

- Place several sheets of newspaper under a large glass trough. Stand the measuring cylinder in the centre of the trough.
- Pour 100 mL of 100 vol hydrogen peroxide into the cylinder. Add a generous squirt of detergent.
- Fill a spatula with potassium iodide crystals and add them to the liquid. Note the change of temperature.

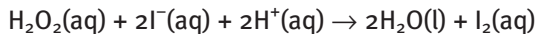
#### Theory

Hydrogen peroxide decomposes slowly in the absence of a catalyst, forming water and oxygen.



This process is so slow that hydrogen peroxide may be safely stored in sealed glass bottles at room temperature.

Addition of a catalyst such as potassium iodide lowers the activation energy for the reaction, causing rapid production of oxygen gas. The detergent causes this gas to produce a column of foam. The column is yellow because  $\text{I}^-$  ions also react with hydrogen peroxide, forming iodine.



#### Discussion

- What is the function of a catalyst?
- How does a catalyst increase the rate of a reaction?
- Is the reaction endothermic or exothermic?
- Pure liquid hydrogen peroxide has been used as a rocket fuel. Why would it be suitable for that purpose?

#### materials

- 100 mL of 100 vol hydrogen peroxide
- potassium iodide
- detergent
- 500 mL measuring cylinder
- large glass pneumatic trough
- large spatula
- newspaper

#### safety

- Wear gloves, safety glasses and a laboratory coat for this experiment.
- 100 vol hydrogen peroxide can cause severe burns to the skin and eyes.
- Potassium iodide must not be added to hydrogen peroxide of this concentration in the absence of detergent because the reaction becomes violent and the heat released causes boiling to occur.

## Experiment 15.4

### Rate of reaction of antacid tablets

#### materials

- 4 × Alka Seltzer tablets
- 10 g baking soda (sodium hydrogen carbonate)
- 10 g citric acid or white vinegar (a solution of ethanoic (acetic) acid)
- 10 mL hot water (at about 60°C)
- 10 mL ice-water
- water at room temperature
- small plastic bag
- 8 × test tubes
- 2 × 100 mL beakers
- 10 mL graduated pipette
- pipette filler
- thermometer
- glass stirring rod
- spatula
- ice

#### safety

- Wear safety glasses and a laboratory coat for this experiment.

#### Purpose

To investigate factors affecting the rate of the reaction between sodium hydrogen carbonate and citric acid in effervescent antacid tablets (Alka Seltzer).

#### Method

##### A. Particle size

Break a tablet in half and place one half of the tablet in a plastic bag. Crush this half tablet using the back of a spatula. Pour 10 mL of water into each of two test tubes. At exactly the same time, pour the crushed tablet into one test tube and drop the other half of the tablet into the second tube. Note which reaction is faster.

##### B. Temperature

Pour some water that has been chilled to about 10°C with ice into one test tube to a depth of about 4 cm. Pour a similar volume of water at room temperature into a second test tube. Pour a similar volume of hot water (at about 60°C) into a third test tube. At exactly the same time, drop half of a tablet into each test tube. Note which reaction is fastest and which one is slowest.

##### C. Concentration (Student design)

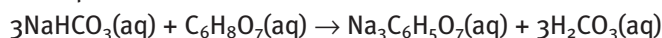
You are provided with baking soda (sodium hydrogen carbonate in powder form) and citric acid powder. Design an experiment to determine the effect of the concentration of a citric acid solution on the rate of its reaction with baking soda.

Prepare a table that fully records your experimental design as well as the results of these tests.

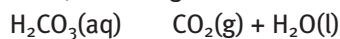
#### Theory

Effervescent antacid tablets, such as Alka Seltzer, contain ingredients that are able to react when the particles collide in solution and produce carbon dioxide gas. The tablets used in this experiment contain sodium hydrogen carbonate

(a base) and citric acid. Citric acid behaves as a triprotic acid, each molecule donating three protons. The equation for the reaction between the base and acid in aqueous solution is:



In this reaction the hydrogen carbonate ion behaves as a proton acceptor (base), forming carbonic acid molecules ( $\text{H}_2\text{CO}_3$ ) that decompose in aqueous solution, releasing carbon dioxide gas:



#### Discussion

- 1 Explain why the sodium hydrogen carbonate and citric acid present in the tablets do not react appreciably until the tablets are added to water.
- 2 How is the rate of the reaction affected by decreasing the particle size of the effervescent tablets? Explain this result in terms of collision theory.
- 3 How is the rate of the reaction affected by increasing the temperature of the water in which the tablet dissolves? Explain this result.
- 4 How is the rate of reaction affected by increasing the concentration of citric acid solution? Explain this result.

## Questions

- Define the following terms.
  - substrate
  - catalyst
  - homogeneous catalyst
  - heterogeneous catalyst
  - activation energy
  - collision theory
- Consider the reaction
 
$$4\text{NH}_3(\text{g}) + 7\text{O}_2(\text{g}) \rightarrow 4\text{NO}_2(\text{g}) + 6\text{H}_2\text{O}(\text{g})$$
 Explain what effect each of the following conditions would have on the rate of this reaction in terms of the collision theory.
  - increasing the temperature inside the reacting vessel
  - decreasing the pressure inside the reacting vessel
  - increasing the concentration of ammonia and oxygen inside the vessel
  - addition of a catalyst to the reacting vessel
  - decreasing in volume of the reaction vessel
- What are two ways you could measure the rate of a reaction?
- Explain the difference between an enzyme and an inhibitor with the use of a diagram.
- Why are most enzymes homogeneous catalysts?
- Why do industrial chemists prefer heterogeneous catalysts for their large-scale reactions?
- Three energy profile diagrams are shown in figure 15.12. All the diagrams are drawn to the same scale.
  - Identify which reactions are exothermic and which are endothermic.
  - Which reaction has the highest activation energy?
  - Which reaction has the lowest activation energy?
  - The addition of a catalyst would most likely have the greatest effect on which reaction? Explain your answer.
- Explain each of the observations listed below in terms of collision theory.
  - Food spoils quicker in the sun than in the refrigerator.
  - A cigarette will smoulder away under normal conditions, but burst into flames in the presence of pure oxygen.
  - A large piece of wood burns more slowly than the same piece of wood separated into smaller pieces.
  - Hydrogen peroxide decomposes into water and oxygen much faster in the presence of a catalyst.

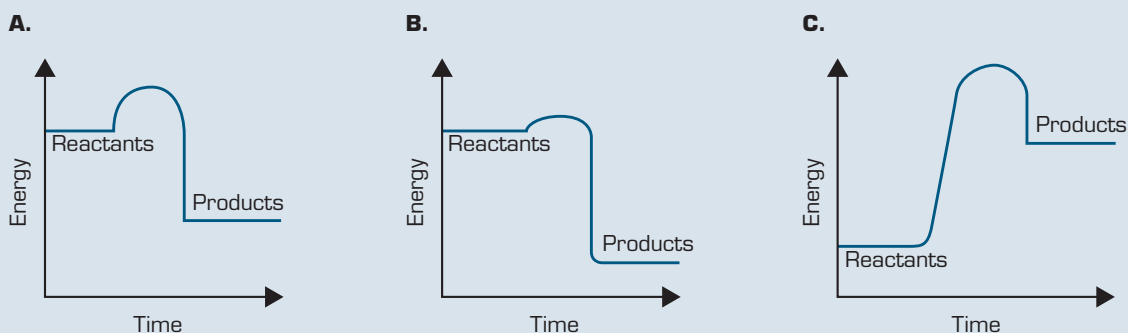


figure 15.12

## 15.2 Reaction mechanisms

In some reactions, products are formed in only a single step. These reactions are called **elementary reactions**. Many reactions do not happen in a single step and are more complex.

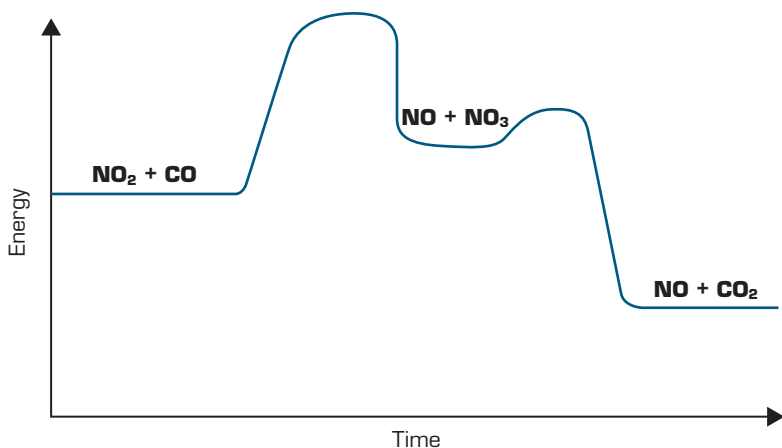
These more complex reactions take several elementary reactions or steps before the final product of the reaction is formed. During these steps **intermediates** are formed for each elementary reaction. These intermediates react straight away to start the next elementary reaction. The sum of all these elementary reactions is called the **reaction mechanism**.



A **reaction mechanism** outlines all the elementary reactions that occur in a chemical reaction.



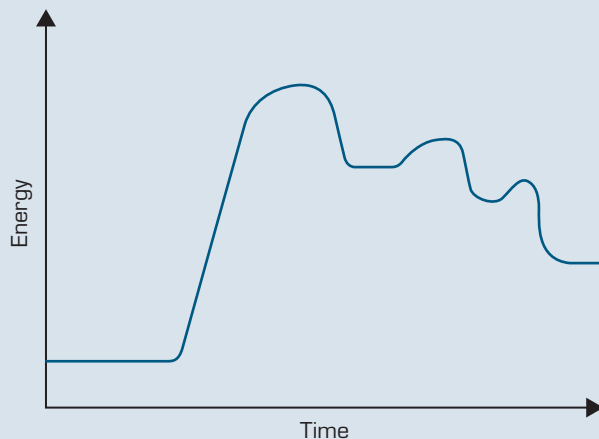




**figure 15.14** The diagram above depicts the energy changes that occur in the reaction between nitrogen dioxide and carbon monoxide.

## Questions

- 9 Define the following terms.
- elementary reaction
  - intermediate
  - rate-determining step
  - reaction mechanism
- 10 The reaction between nitrogen dioxide and fluorine has the overall reaction:
- $$2\text{NO}_2(\text{g}) + \text{F}_2(\text{g}) \rightarrow 2\text{NO}_2\text{F}(\text{g})$$
- The reaction mechanism is:
- $$\begin{array}{l} \text{NO}_2(\text{g}) + \text{F}_2(\text{g}) \rightarrow \text{NO}_2\text{F}(\text{g}) + \text{F}(\text{g}) \quad (\text{slow}) \\ \text{NO}_2(\text{g}) + \text{F}(\text{g}) \rightarrow \text{NO}_2\text{F}(\text{g}) \quad (\text{fast}) \\ \hline 2\text{NO}_2(\text{g}) + \text{F}_2(\text{g}) \rightarrow 2\text{NO}_2\text{F}(\text{g}) + \text{energy} \end{array}$$
- Which step is the rate-determining step?
  - Identify the intermediate in the reaction.
  - What is the overall equation for the reaction?
  - Draw an energy profile diagram for this reaction. (The overall reaction is exothermic.)
- 11 Examine the energy profile diagram in figure 15.15.
- How many elementary reactions are there?
  - How many intermediates are there?
  - This reaction is exothermic overall. True or false? Explain.
  - Which elementary reaction is the rate-determining step and why?

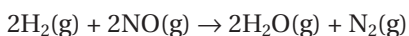


**figure 15.15**

## 15.3 Order of reactions and rate laws

The concentration of reactants is one of the factors shown to influence the rate of a reaction. Chemists can carefully control changes in the concentration of reactants and then analyse the effect they have on the reaction rate.

For example, the reaction between hydrogen and nitrogen monoxide:



produces the results shown in table 15.1.

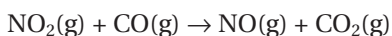
**table 15.1** The changes in reaction rate for the reaction between hydrogen and nitrogen monoxide.

	Initial $[\text{H}_2]$ ( $\text{mol L}^{-1}$ )	Initial $[\text{NO}]$ ( $\text{mol L}^{-1}$ )	Rate ( $\text{mol L}^{-1} \text{s}^{-1}$ )
experiment 1	$2.0 \times 10^{-2}$	$2.5 \times 10^{-2}$	$4.8 \times 10^{-6}$
experiment 2	$2.0 \times 10^{-2}$	$1.25 \times 10^{-2}$	$2.4 \times 10^{-6}$
experiment 3	$2.0 \times 10^{-2}$	$5.0 \times 10^{-2}$	$9.6 \times 10^{-6}$
experiment 4	$1.0 \times 10^{-2}$	$5.0 \times 10^{-2}$	$4.8 \times 10^{-6}$
experiment 5	$3.0 \times 10^{-2}$	$5.0 \times 10^{-2}$	$14.4 \times 10^{-6}$

Compare experiments 1 and 2. When the concentration of nitrogen monoxide is halved, the reaction rate halves. When the concentration of nitrogen monoxide in experiment 3 is increased by a factor of four compared to experiment 2, so is the reaction rate. As the concentration of hydrogen is kept constant during experiments 1, 2 and 3, the rate of the reaction is shown to be directly proportional to the concentration of nitrogen monoxide. The reaction is said to be **first order** with respect to the concentration of the reactant nitrogen monoxide.

In experiments 3, 4 and 5 the concentration of nitrogen monoxide is kept constant and the concentration of hydrogen varied. The concentration of hydrogen in experiment 4 is half that in experiment 3 and so is the reaction rate. The concentration of hydrogen in experiment 5 is increased by a factor of three compared to experiment 4 and so is the reaction rate. The reaction rate is directly proportional to the concentration of hydrogen. The reaction is also said to be first order with respect to the concentration of hydrogen.

For the reaction:



the results of table 15.2 were produced.

**table 15.2** The results of the reaction between nitrogen dioxide and carbon monoxide.

	$[\text{NO}_2]$ ( $\text{mol L}^{-1}$ )	$[\text{CO}]$ ( $\text{mol L}^{-1}$ )	Rate ( $\text{mol L}^{-1} \text{s}^{-1}$ )
experiment 1	0.05	0.10	$3.0 \times 10^{-4}$
experiment 2	0.10	0.10	$12 \times 10^{-4}$
experiment 3	0.10	0.20	$12 \times 10^{-4}$
experiment 4	0.10	0.40	$12 \times 10^{-4}$

The concentration of nitrogen dioxide in experiment 2 is twice that of experiment 1; however, in this case the reaction rate has increased by a factor of four. The reaction is said to be **second order** with respect to the concentration of nitrogen dioxide.

In experiments 2, 3 and 4 the concentration of nitrogen dioxide is kept constant and the reaction rate remains constant despite variations to the concentration of carbon monoxide. The reaction is described as being **zero order** with respect to the concentration of carbon monoxide.

## Rate laws

Chemists use the **rate law** expression to summarise the effect that the concentration of reactants has on the reaction rate. Consider the general equation:



If the order of reaction with respect to the concentration of reactant A is  $x$  and the order of reaction with respect to the concentration of reactant B is  $y$ , then the rate law of this general equation is represented as:

$$\text{Rate} = k[\text{A}]^x[\text{B}]^y$$

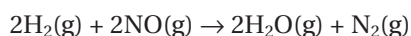
where rate = rate of reaction in  $\text{mol L}^{-1} \text{s}^{-1}$

[A] = concentration of reactant A in  $\text{mol L}^{-1}$

[B] = concentration of reactant B in  $\text{mol L}^{-1}$

$k$  = rate constant (units vary)

Based on the results of table 15.1, for the reaction:



the rate law for this reaction will be:

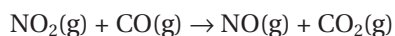
$$\text{Rate} = k[\text{H}_2]^1[\text{NO}]^1 \quad (x = 1, y = 1)$$

The overall order of the reaction is determined by adding those of the individual reactants. In this case:

$$x + y = 1 + 1 = 2$$

The overall reaction is second order.

For the reaction



the rate law will be:

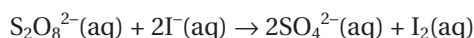
$$\text{Rate} = k[\text{NO}_2]^2 \quad ([\text{CO}]^0 = 1)$$

The overall reaction order can be determined:

$$x + y = 2 + 0 = 2$$

Thus this is a second order reaction.

Consider the reaction



Experimental results can be used to show that the rate law for this expression is:

$$\text{Rate} = k[\text{S}_2\text{O}_8^{2-}]^1[\text{I}^-]^2$$

This reaction is first order with respect to  $\text{S}_2\text{O}_8^{2-}$ , second order with respect to  $\text{I}^-$  and third order overall.

The value of the rate constant,  $k$ , can be determined from the rate law and experimental information.

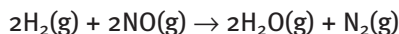


The **rate law** is a mathematical equation that compares the rate of a chemical reaction to the concentration of the reactants. It can only be determined by experimentation.



## ✓ Worked example 15.3A

Calculate the rate constant ( $k$ ) for the reaction.



using the values given for experiment 1 in table 15.1.

The rate law for the reaction is given above.

$$\text{Rate} = k[\text{H}_2]^1[\text{NO}]^1$$

From table 15.1.

$$[\text{H}_2] = 2.0 \times 10^{-2} \text{ mol L}^{-1}$$

$$[\text{NO}] = 2.5 \times 10^{-2} \text{ mol L}^{-1}$$

$$\text{Rate} = 4.8 \times 10^{-6} \text{ mol L}^{-1} \text{ s}^{-1}$$

$$k = ?$$

Substitute values into the rate law.

$$4.8 \times 10^{-6} \text{ mol L}^{-1} \text{ s}^{-1} = k \times [2.0 \times 10^{-2} \text{ mol L}^{-1}] \times [2.5 \times 10^{-2} \text{ mol L}^{-1}]$$

$$k = \frac{4.8 \times 10^{-6} \text{ mol}^{-1} \text{ L}^{-1} \text{ s}^{-1}}{2.0 \times 10^{-2} \text{ mol}^{-1} \text{ L}^{-1} \times 2.5 \times 10^{-2} \text{ mol L}^{-1}}$$

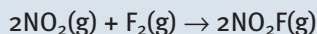
$$= 9.6 \times 10^{-3} \text{ mol}^{-1} \text{ L s}^{-1}$$

### Worksheet 2

Reaction rates and reaction mechanisms

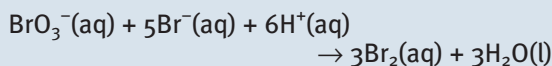
## Questions

- 12 The rate law for the reaction below is supplied. What information does the rate law equation provide about the reaction between nitrogen dioxide and fluorine?



$$\text{Rate} = k[\text{NO}_2]^1[\text{F}_2]^1$$

- 13 The following reaction takes place in acidic solution.



The reaction is first order with respect to  $[\text{BrO}_3^-]$  and  $[\text{Br}^-]$  and second order for  $[\text{H}^+]$ . What is the rate law for the reaction and the order of reaction overall?

- 14 Consider the reaction:



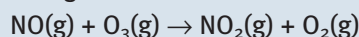
Varying the concentration of  $\text{PCl}_5$  gave the results shown in table 15.3.

**table 15.3** The results of the decomposition of  $\text{PCl}_5$ .

	$[\text{PCl}_5]$ ( $\text{mol L}^{-1}$ )	Rate ( $\text{mol L}^{-1} \text{ s}^{-1}$ )
experiment 1	0.10	$6.0 \times 10^{-6}$
experiment 2	0.20	$24 \times 10^{-6}$
experiment 3	0.30	$54 \times 10^{-6}$

- a What is the order of the reaction with respect to  $\text{PCl}_5$ ?
- b What is the overall order of the reaction?
- c Determine the value of the rate constant using the data in experiment 1.

- 15 Testing was conducted on the reaction between nitrogen monoxide and ozone:



and the results in table 15.4 were obtained.

**table 15.4** The results of the reaction between NO and  $\text{O}_3$ .

	Initial [NO] ( $\text{mol L}^{-1}$ )	Initial [ $\text{O}_3$ ] ( $\text{mol L}^{-1}$ )	Initial rate ( $\text{mol L}^{-1} \text{ s}^{-1}$ )
experiment 1	0.0100	0.200	$1.0 \times 10^{-6}$
experiment 2	0.0400	0.200	$4.0 \times 10^{-6}$
experiment 3	0.0200	0.200	$2.0 \times 10^{-6}$
experiment 4	0.0200	0.800	$8.0 \times 10^{-6}$
experiment 5	0.0200	1.600	$16.0 \times 10^{-6}$

- a What is the order of the reaction with respect to nitrogen monoxide?
- b What is the order of the reaction with respect to ozone?
- c Write the rate law for the reaction.
- d Determine the value of the rate constant in experiment 3.



## Summary ▶▶▶▶

- ▶ Reactions can range in speed from the very fast to the very slow. The rate of a reaction can be explained using **collision theory**, which is a model that describes how the rate of a chemical reaction is determined by the collisions between reacting particles.
- ▶ The rate of a reaction is also determined by the **activation energy** of the reaction, which is the minimum energy required for a collision between reacting particles to result in new products.
- ▶ **Energy profile diagrams** depict the energy changes that occur during the course of a reaction.
- ▶ There are four factors that can influence the speed of a reaction: temperature, concentration, surface area, and the presence of a **catalyst**.
- ▶ Catalysts are substances that speed up a chemical reaction without being consumed. Catalysts can be classified as either **homogenous** or **heterogeneous**. Homogeneous catalysts are catalysts that operate in the same physical state as the reacting particles.
- ▶ Heterogeneous catalysts are catalysts that operate in a different state to the reacting particles.
- ▶ **Enzymes** are biological catalysts that bind to a **substrate**. A substrate is a biological substance such as a protein that is acted on by an enzyme. Enzymes can be acted on by **inhibitors**. Inhibitors are substances that bind to the active site of an enzyme reducing its catalytic activity.
- ▶ Many reactions are complex and involve multiple steps called **elementary reactions**. An elementary reaction is a single step in the overall **reaction mechanism**. **Intermediates** are formed for each elementary reaction. A reaction mechanism outlines all the elementary reactions that occur in a chemical reaction. The slowest elementary reaction in the overall reaction mechanism is the **rate-determining step**.
- ▶ The **rate law** is a mathematical equation that relates the rate of a chemical reaction to the concentration of the reactants.

## Key terms ▶▶

activation energy  
catalyst  
collision theory  
elementary reaction

energy profile diagram  
enzyme  
heterogeneous catalyst  
homogeneous catalyst

inhibitor  
intermediate  
rate-determining step  
rate law

reaction mechanism  
substrate



## Chapter Review

### 15.1 Reaction speed

- 16 Which of the following statements about a catalyst is true?
- A Only a small amount of a catalyst is consumed in a reaction.
  - B A catalyst can occur as a reactant or product in the overall equation.
  - C A catalyst decreases the  $\Delta H$  of the reaction.
  - D The proportion of molecules with sufficient energy to react is increased by the addition of a catalyst.
- 17 Which of the following does not change the rate of collisions between particles in a reaction?
- A addition of a catalyst
  - B increase in surface area
  - C increase in temperature
  - D decrease in the reaction volume
- 18 Account for the following observations with reference to the collision model of particle behavior.
- a Surfboard manufacturers find that fibreglass plastics set within hours in summer but may remain tacky for days in winter.
  - b A bottle of fine aluminium powder has a caution sticker warning that it is 'highly flammable, dust explosion possible'.
  - c An egg cooks more slowly in a billy of boiling water on a trekking holiday in Nepal than when boiled in a similar way in the Australian bush.
- 19 The activation energy of the forward reaction of a reaction is greater than that of the reverse reaction. Is this an exothermic or endothermic reaction? Explain.

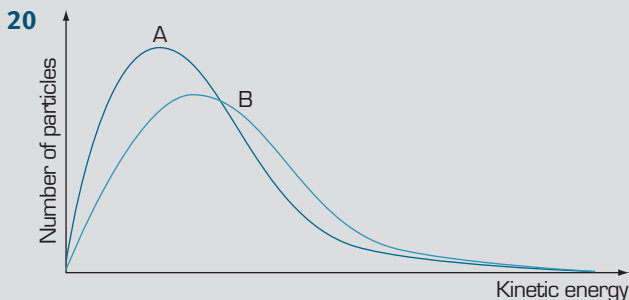


figure 15.16

- a Figure 15.16 shows the kinetic energy profile of particles at two different temperatures,  $40^{\circ}\text{C}$  and  $60^{\circ}\text{C}$ . Indicate the temperatures represented by graph A and graph B.
- b Draw a graph of number of particles versus kinetic energy that shows the effect of a catalyst of a reaction.

- c Use the diagram you have drawn in part b to explain in terms of collision theory how a catalyst increases the rate of a reaction.
- 21 If a sugar cube is held in the flame of a candle, the sugar melts and browns but does not burn. However, the cube will burn if salt is first rubbed into it, even though the salt does not react. Explain the effect of the salt on the activation energy of this combustion reaction.
- 22
- a Explain why surface properties are important to the operation of catalysts.
  - b Many industrial catalysts are made into porous pellets. What is the reason for this?
- 23 Consider the following reactions: wood burning on a camp fire, bathroom tiles being cleaned, a cake baking and a tomato plant growing.
- a How would you speed up the rates of these reactions?
  - b Explain why the methods you suggested produce an increase in the reaction rate.
- 24 Explain the following observations in terms of the behaviour of particles.
- a There have been many explosions in coal mines.
  - b Refrigeration slows down the browning of sliced apples.
  - c Bushfires often start during lightning storms.
  - d Iron anchors from shipwrecks can show little corrosion after years in the sea.
  - e A burning match is used to light a candle, but the candle continues to burn when the match is extinguished.
- 25 What are the main differences between enzymes and inorganic catalysts?
- 26 How does an enzyme increase the rate of a chemical reaction?
- 27 Read the following article and answer the questions.

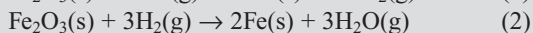
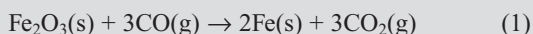
### Exploding iron

IN 1996, while the Turkish ship MV *B. Onal* was riding at anchor in Delaware Bay, near Philadelphia in the USA, a 2 tonne hatch cover suddenly blew off. As the ship was carrying a cargo of iron, the surprised crew asked themselves, 'Can iron explode?'

As you may be aware, traditionally, iron oxide ( $\text{Fe}_2\text{O}_3$ ) is reduced to molten iron in a blast furnace, such as those at Port Kembla in New South Wales.

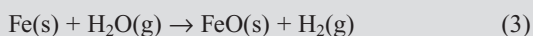
A new process that uses less energy has been developed. Iron oxide is converted directly to solid iron without having to heat the reactants to the melting

point of iron. Iron oxide is heated to 550°C in the presence of carbon monoxide and hydrogen gas. The iron oxide is reduced to iron by both gases, with the formation of carbon dioxide or water.



The pellets of pure iron that are formed are extremely porous and full of many tiny holes, in contrast to the solid formed when the molten iron from a blast furnace cools. Under the right conditions the iron pellets can be oxidised back to iron oxide.

In most cases, iron is oxidised slowly by oxygen back to iron oxide and the resulting heat can readily escape. If the pellets are more than 1 metre deep, as in the hold of a ship, the heat cannot escape quickly enough and the temperature rises. This speeds up the reaction rate. If the temperature increases sufficiently and water is present, another reaction occurs and the oxidation rate is speeded up 100-fold, with the release of more heat:

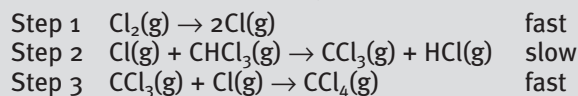


Any spark or fire will set off an explosion of hydrogen gas, and that is what happened on the MV *B. Onal*.

- What is the main reason for the use of less energy in the new reduction process than the old process?
- Write equations showing the oxidation of iron by oxygen to iron(II) oxide and iron(III) oxide.
- If water is present the oxidation rate is speeded up 100-fold. Is water acting as a catalyst? Explain your answer.
- Is the reaction shown in equation 3 endothermic or exothermic?
- List the factors that increased the rate of reaction in equation 3.
- Firefighters were not able to use water to put out the fire in the cargo hold. Why not? Suggest how they could put out the fire.

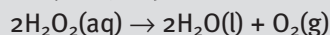
## 15.2 Reaction mechanisms

**28** A reaction has the following reaction mechanism.

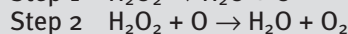
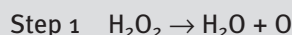


- Identify the intermediates.
- What is the overall reaction?
- Draw an energy profile diagram for this endothermic reaction.

**29** The overall reaction equation for decomposition of hydrogen peroxide is:



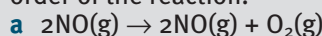
The mechanism for the reaction has two steps.



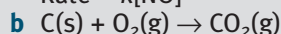
Iodine ions are known to catalyse this reaction. Rewrite the reaction mechanism using iodine as a catalyst.

## 15.3 Order of reactions and rate laws

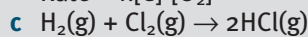
**30** Identify the order of reaction with respect to each reactant, and then identify the overall order of the reaction.



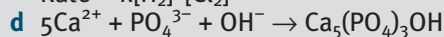
$$\text{Rate} = k[\text{NO}]^2$$



$$\text{Rate} = k[\text{C}]^1[\text{O}_2]^1$$

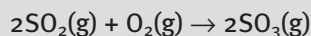


$$\text{Rate} = k[\text{H}_2]^2[\text{Cl}_2]^1$$



$$\text{Rate} = k[\text{Ca}^{2+}]^1[\text{PO}_4^{3-}]^1[\text{OH}^-]^1$$

**31** Measurements were taken for the reaction between sulfur dioxide and oxygen gas.



The test was conducted at 800 kelvin. The results are given in table 15.5.

- What is the order of reaction with respect to oxygen?
- What is the order of reaction with respect to sulfur dioxide?
- What is the overall order of the reaction?
- Write the rate equation for the overall reaction and determine the value of the rate constant.

**table 15.5** The results of the reaction between oxygen and sulfur dioxide.

$[\text{SO}_2]$ (mol L <sup>-1</sup> )	$[\text{O}_2]$ (mol L <sup>-1</sup> )	Rate (mol L <sup>-1</sup> s <sup>-1</sup> )
$4.0 \times 10^{-2}$	$5.00 \times 10^{-2}$	$4.8 \times 10^{-6}$
$4.0 \times 10^{-2}$	$2.50 \times 10^{-2}$	$1.2 \times 10^{-6}$
$4.0 \times 10^{-2}$	$10.00 \times 10^{-2}$	$19.2 \times 10^{-6}$
$2.0 \times 10^{-2}$	$2.50 \times 10^{-2}$	$0.6 \times 10^{-6}$
$8.0 \times 10^{-2}$	$5.00 \times 10^{-2}$	$9.6 \times 10^{-6}$



# 16

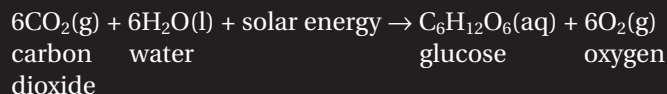
## Reactions of life

The reactions that maintain life on our planet are numerous and complex. Two of the most important chemical reactions are photosynthesis and respiration. Photosynthesis provides a mechanism for plants to make their own food using solar energy, and respiration allows animals and humans to extract energy from food.

### 16.1 Reactions of life

#### Respiration and photosynthesis

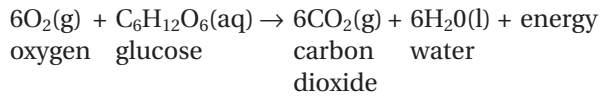
Plants manufacture glucose using a chemical process called **photosynthesis**. The process also requires water and sunlight and a byproduct of the reaction is oxygen. The reaction for photosynthesis is as follows.



Photosynthesis is catalysed by a green pigment called **chlorophyll**. Chlorophyll absorbs sunlight (solar energy) and uses the energy to change carbon dioxide and water into glucose and oxygen. This chemical process occurs primarily in the leaf cells of plants. Plants form the basis of the food chains that provide all animal life with the compounds they need to survive. Animals and plants also use the oxygen created by photosynthesis to produce energy using a chemical process called **respiration**.

**Photosynthesis** is a chemical process that requires sunlight to drive a chemical reaction between carbon dioxide and water, to produce glucose and oxygen.

The equation for respiration is

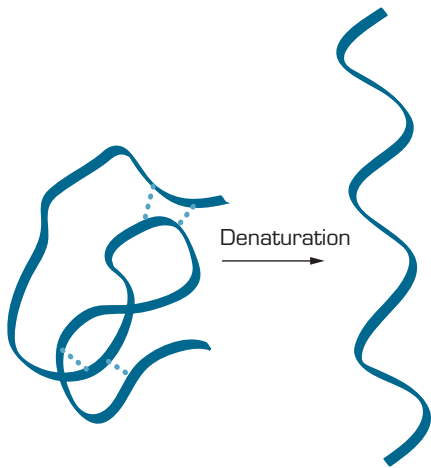


Respiration allows plants and animals to release the chemical energy found in glucose, and use it for other chemical processes throughout the organism.

## Enzymes

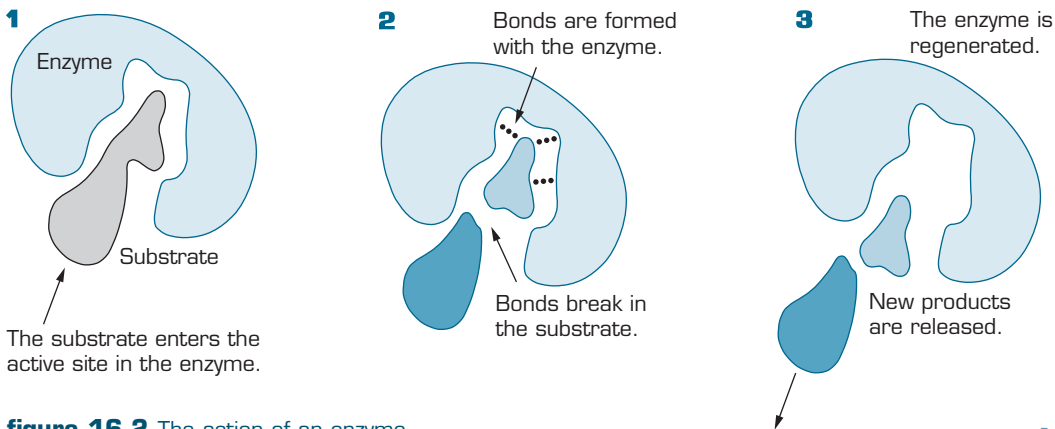
Nearly all the chemical reactions that support life on our planet are catalysed by substances known as **enzymes**. Without enzymes essential biological reactions would happen too slowly for organisms to function normally and survive.

Enzymes are extremely specific and only catalyse a particular reaction. They produce reaction rates  $10^{10}$  times faster than the uncatalysed reaction. Enzymes are affected by fluctuations in temperature and pH. They easily unravel or **denature** under temperatures in excess of  $60^\circ\text{C}$ . The optimal temperature for most of our enzymes is body temperature ( $37^\circ\text{C}$ ).



**figure 16.1** Denaturation alters the structure of a protein chain, making it biologically inactive. An enzyme will not be able to catalyse a reaction once it has been denatured.

An enzyme acts by binding a **substrate** to its active site and causing it to react faster and form new products. When the enzyme binds to the substrate, it weakens bonds and increases the surface area of the substrate, allowing it to react much faster.



**figure 16.2** The action of an enzyme.



**Respiration** is a chemical process during which oxygen reacts with glucose to produce carbon dioxide, water and energy.



A **substrate** is the reacting molecule which binds to an enzyme.

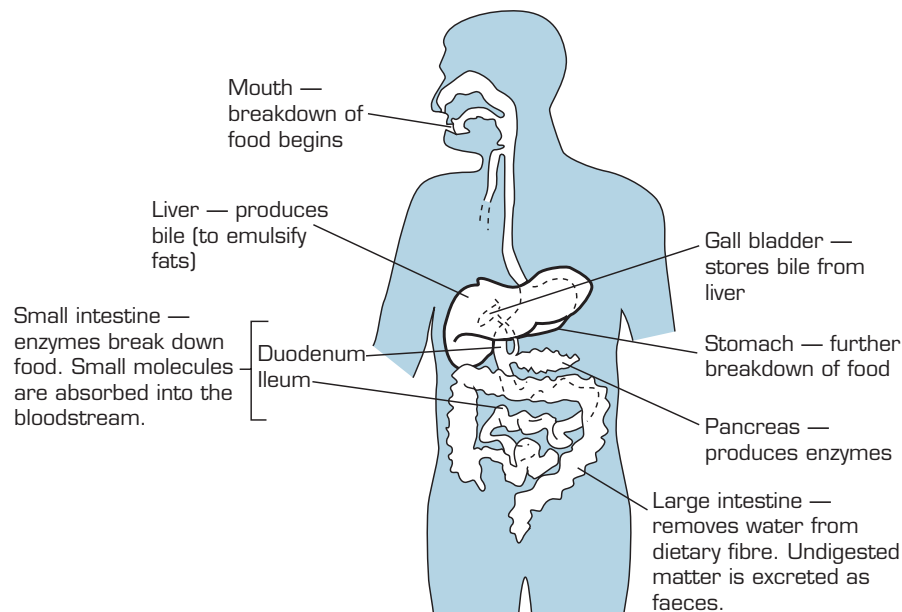


## Questions

- Explain why, in some respects, photosynthesis and respiration can be described as processes that are the reverse of each other.
  - Why does respiration, as well as photosynthesis, occur in plants?
  - Does a plant photosynthesise or respire to a greater degree? Explain.
- Write the equation for the process of photosynthesis.
  - It has been estimated that  $7.9 \times 10^{25}$  g of carbon dioxide is used in photosynthesis each year. What mass of glucose is produced from this amount of photosynthesis each year?
- How does an enzyme increase the rate of a chemical reaction?
  - Digestion of proteins occurs in both the stomach and the small intestine. Trypsin is an enzyme that catalyses the hydrolysis of proteins. Trypsin is secreted into the small intestine, where the pH is approximately 8. Would you expect this same enzyme to be secreted into the stomach, where the pH is approximately 2? Explain your reasoning.

## 16.2 The chemistry of digestion

Before the body can make use of the compounds found in foods it must break them down chemically in a process called digestion. Digestion converts the foods into a form that can be used by the body.



**figure 16.3** The major organs involved and the contribution they make to the digestive process.

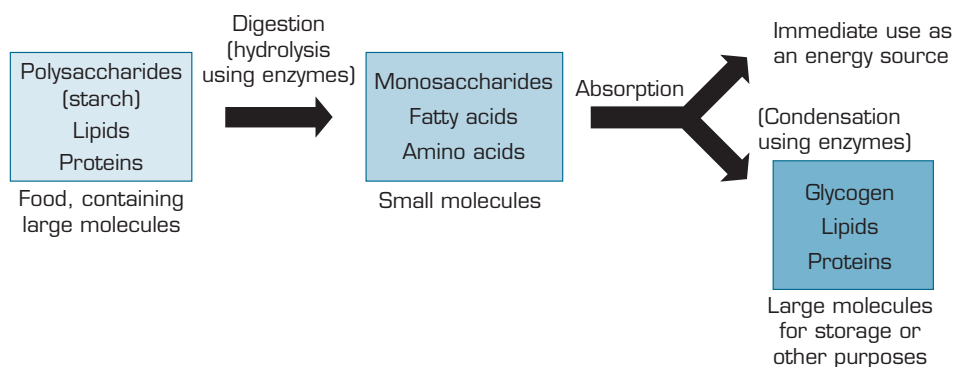
Digestion starts in the mouth where food is physically broken up by the teeth into smaller pieces and chemically broken down by the enzyme amylase, which is present in saliva. With the aid of the lubricating properties of saliva, the small pieces of food travel down the oesophagus and into the stomach. In the stomach the food mixes with other enzymes and hydrochloric acid, which act to break down the food further.

The partially digested food then moves into the small intestine. This is where the bulk of the digestion process takes place. The food is mixed with enzymes secreted by the wall of the small intestine and the pancreas. A yellow liquid called bile is also secreted into the small intestine to assist with the digestion of lipids (fats).

From the small intestine, digested food molecules are absorbed into the blood stream and they are transported to other parts of the body (e.g. liver) to be **metabolised**.

The remaining material passes into the large intestine, where water and any mineral ions are absorbed.

Digestion is used to break down proteins, carbohydrates and lipids, which are natural polymers found in food. The human body can convert energy and other compounds from all three of these polymers by breaking them down into individual monomer units using enzymes. These compounds are broken down using a chemical reaction called **hydrolysis**. These reactions are catalysed by enzymes called **hydrolases**.



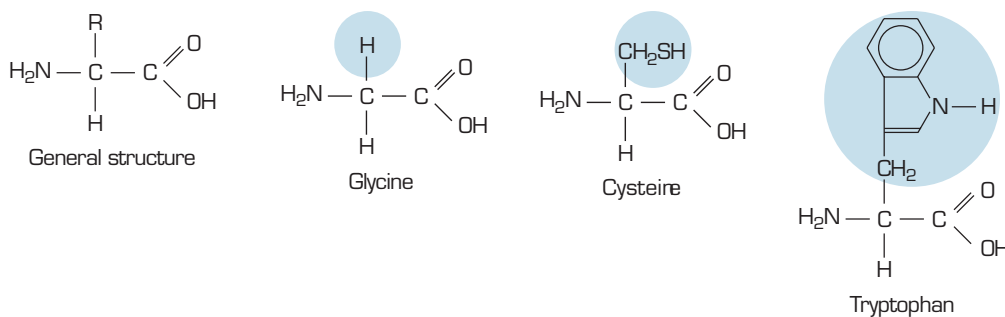
**figure 16.4** The breakdown of the nutrients contained in food and the applications they have in the body.

## Proteins

Proteins are the essential building blocks of life. Every cell in every living organism contains structures created from proteins. All plant and animal proteins are created from chemical structures called amino acids.

There are twenty different types of amino acids and these can form long chains of different combinations to make every protein found in the human body.

All amino acids have the same basic structure: an amino group ( $-\text{NH}_2$ ), a carboxyl group ( $-\text{COOH}$ ) and an R group, which gives the amino acid its identity. R groups vary in complexity and range from a single hydrogen atom, as found in the amino acid glycine, to the complex ring structures that are found in histidine and tryptophan. Table 16.1 shows the R groups for all twenty amino acids found in living things.



**figure 16.5** The general structure of amino acids and some examples. The R groups that distinguish amino acids from each other are circled.



**Metabolism** is the term used to collectively describe all the chemical processes the cells of your body perform, including respiration.



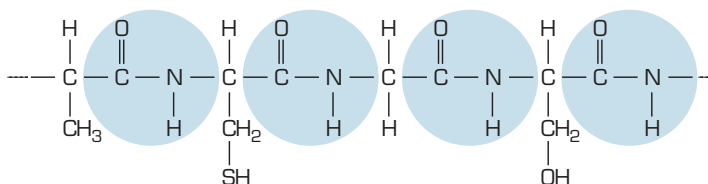
**Proteins** are natural polymers made up of repeating units called **amino acids**.



**table 16.1** The R groups of the twenty amino acids.

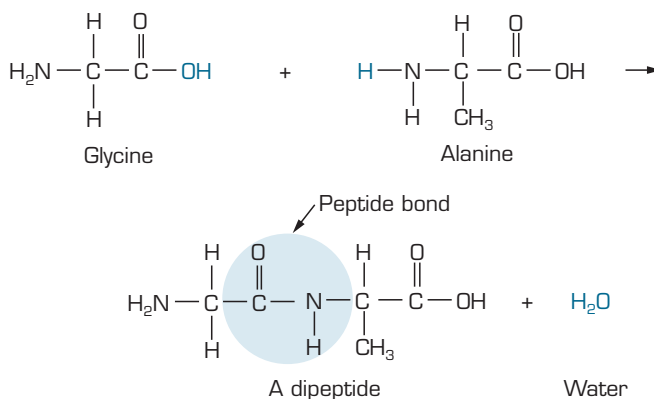
Amino acid	R-	Amino acid	R-
glycine	H-	isoleucine	CH <sub>3</sub> CH <sub>2</sub> CH(CH <sub>3</sub> )-
alanine	CH <sub>3</sub> -	phenylalanine	C <sub>6</sub> H <sub>5</sub> CH <sub>2</sub> -
serine	HOCH <sub>2</sub> -	methionine	CH <sub>3</sub> SCH <sub>2</sub> CH <sub>2</sub> -
cysteine	HSCH <sub>2</sub> -	lysine	H <sub>2</sub> N(CH <sub>2</sub> ) <sub>4</sub> -
ornithine	H <sub>2</sub> N(CH <sub>2</sub> ) <sub>3</sub> -	valine	(CH <sub>3</sub> ) <sub>2</sub> CH-
aspartic acid	HOOCCH <sub>2</sub> -	leucine	(CH <sub>3</sub> ) <sub>2</sub> CHCH <sub>2</sub> -
tyrosine	C <sub>6</sub> H <sub>4</sub> (OH)CH <sub>2</sub> -	threonine	CH <sub>3</sub> CH(OH)-
cystine	HOOCCH(NH <sub>2</sub> )CH <sub>2</sub> S <sub>2</sub> CH <sub>2</sub> -	tryptophan	
arginine	HN=C(NH <sub>2</sub> )NH(CH <sub>2</sub> ) <sub>3</sub> -	histidine	
glutamic acid	HOOC(CH <sub>2</sub> ) <sub>2</sub> -		
norleucine	CH <sub>3</sub> (CH <sub>2</sub> ) <sub>3</sub> -		

Amino acids are linked together to form proteins using a peptide bond (figure 16.7). When your body ingests proteins, enzymes break the peptide bonds and form individual amino acids, which can then be linked to form new proteins. The process of hydrolysing the protein into individual amino acids is illustrated in figures 16.8 and 16.9.



**figure 16.6** The peptide bonds link amino acids in this protein (circled).

The peptide bond is created by a **condensation reaction** between the amino group of one amino acid and the carboxyl group of another. Condensation reactions are catalysed by enzymes and **coenzymes** (vitamins). Two amino acids linked together form a dipeptide, three or more form a polypeptide.

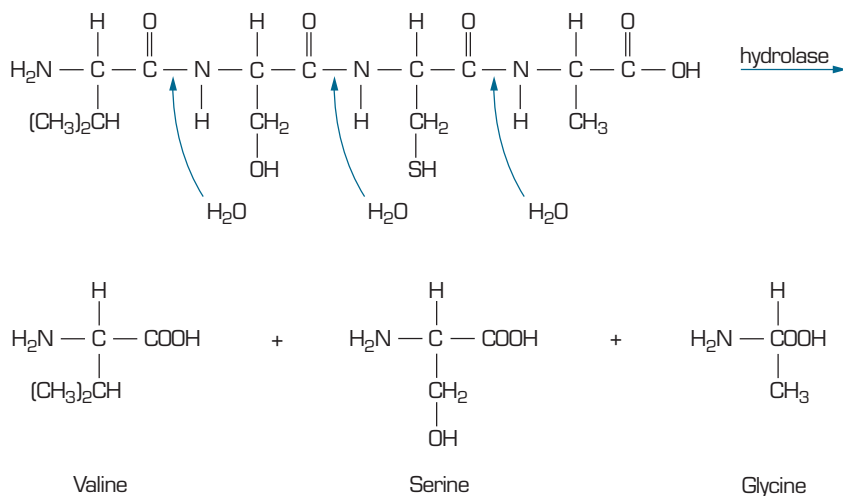


**Figure 16.7** The amino acids glycine and alanine joining to form a dipeptide. The bond that links the two amino acids is called a peptide bond (circled).

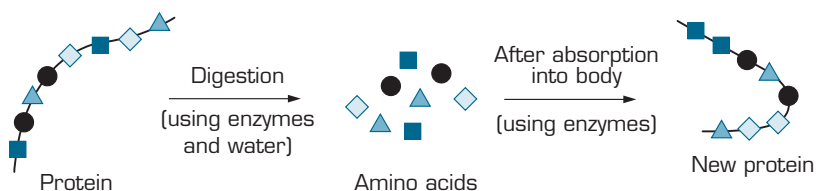
Reactions that involve the combination of two reactants and the elimination of a small molecule, such as water, are called **condensation reactions**.

Coenzymes or vitamins act by activating other enzymes.





**figure 16.8** A protein polymer is broken into its individual amino acids using enzymes called hydrolases.



**figure 16.9** The protein is broken down into its individual amino acids and then re-sequenced to form a new protein to be used by the body.

A peptide is a chain made of two or more amino acids linked together. An average sized protein consists of a peptide chain containing at least 50 amino acids. The sequence in which amino acids are linked determines the property of the peptide or protein.

Protein function is predominantly determined by primary structure (the sequence of amino acids in a protein). The shape of a protein also influences its function. The secondary structure is the shape of a protein caused by coiling or folding of the chain. For example, the protein keratin that forms hair has a helical structure due to hydrogen bonding between the amino groups and the carboxyl groups of the peptide chain.



Hydrogen bonding is the strongest type of intermolecular attraction between molecules.

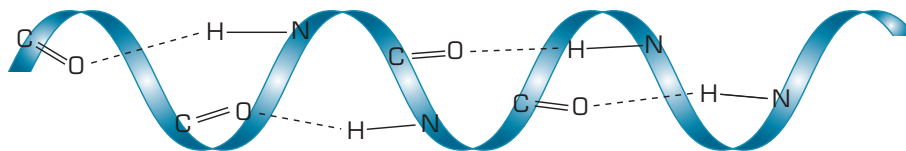
**table 16.2** Important proteins and their functions.

Type	Function	Examples
structural	protection, support, movement	skin, bone, cartilage, ligaments, tendons, muscle, hair, teeth, feathers, beaks, cocoons and exoskeletons in insects
enzymes	biological catalysts	enzymes involved in digestion
hormones	regulation of body functions	insulin
transport	movement of compounds between and within cells	haemoglobin
protective	defence	antibodies
toxins	attack	snake and spider venoms
most proteins	energy source	

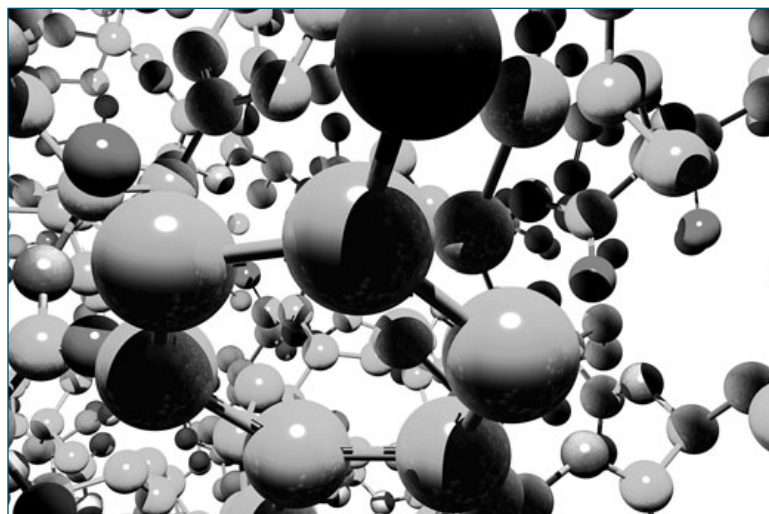


A disulfide bridge or link is found in many proteins, allowing the chains to be linked together using a  $-S-S-$  bond.

The tertiary structure of a protein is determined by the amino and carboxyl groups of the amino acids present in the chain. Certain functional groups can form cross-links between the chains, such as disulfide bridges, that alter the overall three-dimensional shape of the protein. This can result in an overall shape that is helical, compact or globular.



**figure 16.10** The hydrogen bonding between amino acids in a single peptide chain can result in a helical shape.



**figure 16.11** The hormone insulin has a globular tertiary structure.

## Carbohydrates

The term carbohydrate describes a group of carbon-based compounds that can be simple sugar molecules or long chain structures consisting of thousands of repeating monomers. They are used by humans for energy. Carbohydrates consist of only three elements, carbon, hydrogen and oxygen.

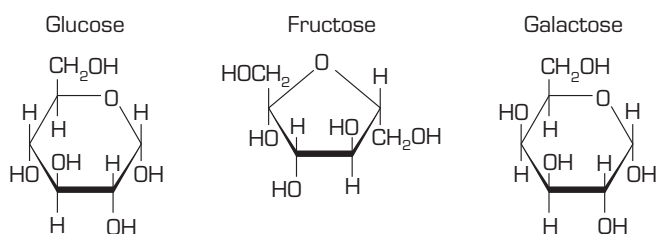
**table 16.3** Some important carbohydrates, their composition and sources.

Carbohydrate	Composition	Where found
<i>Monosaccharides</i>		
glucose	$C_6H_{12}O_6$	fruit juices
fructose	$C_6H_{12}O_6$	fruit juices, honey
galactose	$C_6H_{12}O_6$	not found naturally
<i>Disaccharides</i>		
maltose	glucose + glucose	germinating grain
sucrose	glucose + fructose	sugar cane, sugar beet
lactose	glucose + galactose	milk
<i>Polysaccharides</i>		
glycogen	<i>Polymer of:</i> glucose	energy store in animals
starch	glucose	energy store in plants
cellulose	glucose	plant fibre

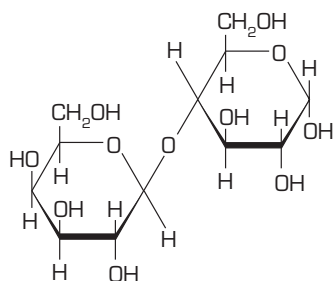
Carbohydrates are compounds that are used for energy by living organisms.

Simple sugars, such as glucose, fructose and galactose, are monosaccharides and composed of a single ring structure. Glucose is the most common monosaccharide and the most important, as it combines with oxygen to produce energy in living cells.

Disaccharides are also regarded as simple sugars; they consist of two monomers bonded together. Maltose, sucrose and lactose are disaccharides. Lactose is the main carbohydrate found in cow's milk. Sucrose is commonly referred to as table sugar and is used for sweetening coffee and cooking because of its pleasant taste. Both monosaccharides and disaccharides are soluble in water, sweet tasting and readily release energy for use by the body.

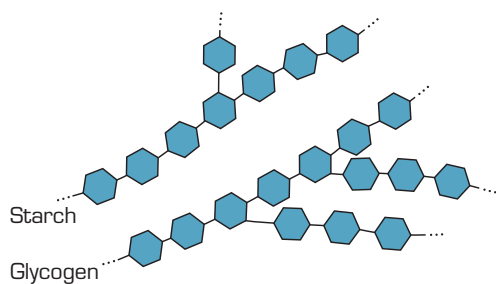


**figure 16.12** The structural formulae of three different monosaccharides.



**figure 16.13** The structural formula of the disaccharide lactose.

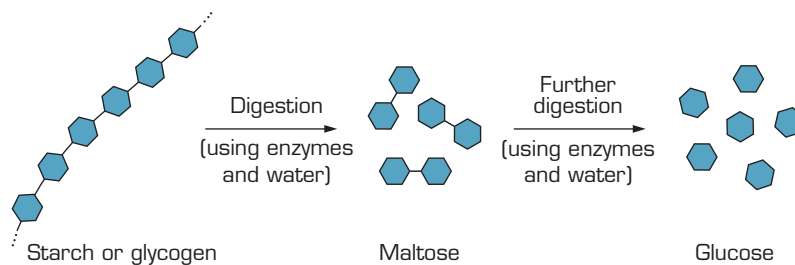
Polysaccharides such as cellulose, glycogen and starch consist of long chains of repeating monosaccharides. Starch is found in foods such as bread and potatoes. Polysaccharides are natural polymers.



**figure 16.14** Complex carbohydrates such as starch and glycogen are formed from repeating glucose monomers. Note that glycogen has a branched structure.

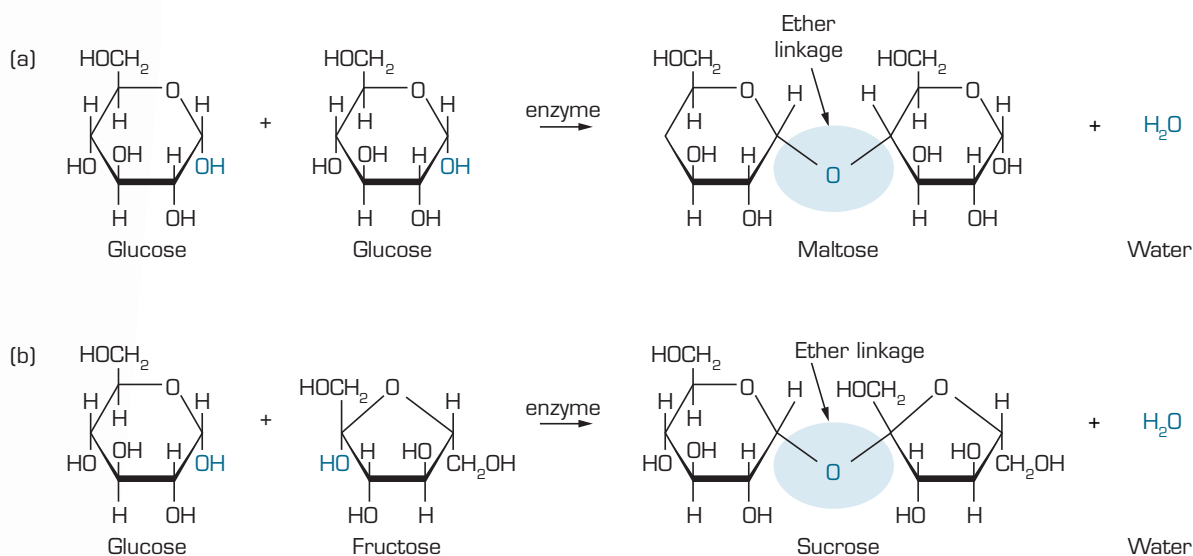
Polysaccharides are complex carbohydrates and provide a steady release of energy as the body breaks them down into usable monomer units. The body then uses the monosaccharides to release energy. Starch and glycogen can be broken down into individual glucose molecules, which are then used to release energy by the process of respiration. The hydrolysis reactions that break down starch and glycogen are catalysed by hydrolases.





**figure 16.15** Polysaccharides can be broken down into individual glucose molecules, which are then used to generate energy during respiration.

Monosaccharides can be re-joined to form disaccharides in a chemical process called a condensation reaction. The bond formed between the two monosaccharides is called an ether link ( $R-O-R$ ). This is the bond that is severed when carbohydrates are hydrolysed. These reactions are also catalysed by the actions of enzymes and coenzymes. This process can continue to form polysaccharides; for example, the body creates stores of glucose by converting it to glycogen.



**figure 16.16** (a) Two glucose monomers can be linked via a condensation reaction to form the disaccharide maltose. (b) A glucose monomer and a fructose monomer are linked to form sucrose, another disaccharide.

# Experiment 16.1

## The effect of pH on enzyme action

### Introduction

Enzymes are protein molecules that act as catalysts in biochemical reactions. The enzyme amylase catalyses the breakdown of starch to glucose. In this investigation you will determine the effect of temperature and pH on the action of the enzyme amylase.

### Purpose

To examine the affect of the enzyme amylase under various conditions.

### Method A: observing colour changes to starch solution with and without amylase

- 1 Prepare a water bath at 37°C.
- 2 Label two test tubes A and B.
- 3 To each test tube add 5 mL starch solution.
- 4 Add 2 mL distilled water to A and 2 mL amylase to B.
- 5 Place the test tubes in the water bath for 5 minutes.
- 6 Remove from the water bath and add 2–3 drops of iodine solution to each test tube. Record your observations in table 16.4.

table 16.4

Test tube	Temperature (°C)	Starch (mL)	Addition	Time for mixture to react (min)	Observations
A	37	5	2 mL distilled water	5	
B	37	5	2 mL amylase	5	

### Discussion

- 1 What is the purpose of this investigation?
- 2 Why is a temperature of 37°C used?
- 3 Assuming that the breakdown of starch by amylase in test tube B is almost complete, what colour changes would you expect to see for partially complete reactions?

### Method B: the effect of heat on the action of amylase

- 1 Label five test tubes A, B, C, D and E.
- 2 To each test tube add 5 mL starch solution.
- 3 Place test tube A in ice water and allow it to equilibrate to 0°C.
- 4 Add 2 mL amylase. Leave for 5 minutes at 0°C.
- 5 Remove from the ice water and add 2–3 drops of iodine solution.
- 6 Record observations in table 16.5. The intensity of colour change could be recorded using symbols: ++ for a dark colour change, + for a lighter colour change, and – for no colour change.
- 7 Repeat steps 3 to 6 for test tube B, but leave the test tube at room temperature for 5 minutes. Measure and record the room temperature in table 16.5.
- 8 Repeat steps 3 to 6 for test tube C, but place the test tube in a 37°C water bath.

### materials

#### (per group)

- 60 mL 2% starch solution
- 22 mL 1.5% amylase solution
- 0.12 M KI/0.05 M I<sub>2</sub> solution
- 2.5 mL 0.1 M hydrochloric acid
- 2.5 mL 0.1 M sodium hydroxide
- distilled water
- narrow range pH paper
- 12 large test tubes
- 2 × 10 mL measuring cylinders
- dropper for iodine solution
- thermometer (–10 to 110°C)
- marking pen
- ice cubes in water in 250 mL beaker
- water bath (thermostatically controlled hot plate or a 600 mL beaker with water from hot water tap, cooled and maintained at 37°C)
- Bunsen burner and heatproof mat
- tripod and gauze

### safety

- Wear safety glasses and a laboratory coat for this experiment.
- Iodine solution is toxic by all routes of exposure. It also stains skin and clothing.
- Hydrochloric acid is corrosive.
- Sodium hydroxide is corrosive. It is toxic if ingested.



- Repeat steps 3 to 6 for test tube D, but place the test tube in a beaker with hot water from the hot water tap. Measure and record the temperature of this water in table 16.5.
- Repeat steps 3 to 6 for test tube E, but place the test tube in a beaker of boiling water (100°C).

table 16.5

Test tube	Temperature (°C)	Starch (mL)	Amylase (mL)	Time for mixture to react (min)	Colour change (++, +, -)
A	0	5	2	5	
B		5	2	5	
C	37	5	2	5	
D		5	2	5	
E	100	5	2	5	

### Discussion

- Describe the variations in enzyme activity at the different temperatures. At which temperature was the reaction slowest? At which temperature was the reaction fastest?
- At which temperature would you say that the enzyme was working at its optimum capacity?
- Explain, in terms of the kinetic theory of particles, the observations at 0°C.
- Explain, in terms of the protein structure and shapes, the result observed at 100°C.

### Method C: the effect of pH on the action of amylase

- Label five test tubes A, B, C, D and E.
- To each test tube add 5 mL starch solution.
- To test tubes A and B add 2 mL and 0.5 mL hydrochloric acid respectively. Check the pH of the contents of each test tube with pH paper. Record the results in table 16.6.
- To test tubes C and D, add 2 mL and 0.5 mL sodium hydroxide respectively. Check the pH of the contents of each test tube and record in table 16.6.
- Leave test tube E as a control.
- Add 2 mL amylase to each of test tubes A–E. Leave for 5 minutes at 37°C.
- Remove the test tubes from the water bath and add 2–3 drops of iodine solution. Record any colour changes.

### Discussion

- Compare the enzyme activities at the different pH levels.
- At what pH does amylase work best?

table 16.6

Test tube	Temperature (°C)	Starch (mL)	Additions	pH	Amylase (mL)	Time for mixture to react (min)	Colour change (++, +, -)
A	37	5	2 mL acid	2	2	5	
B	37	5	0.5 mL acid	2	2	5	
C	37	5	2 mL NaOH	2	2	5	
D	37	5	0.5 mL NaOH	2	2	5	
E	37	5	–	2	2	5	

# Experiment 16.2

## Modelling structures of carbohydrates

materials  
(per group)

- molecular model kit

### Purpose

To investigate the structure of glucose and glycogen.

### Method

- 1 Use the Internet or other resources to research the straight chain and cyclical structures of  $\alpha$ -glucose. Draw these structures, numbering the carbon atoms in both forms of the glucose structures.
- 2 Construct the models for these structures of glucose.
- 3 Draw two cyclical forms of glucose and show how they combine to form a disaccharide (2-glucose unit) molecule.
- 4 Construct a model of this disaccharide.
- 5 Glycogen is a polymer made up of monomer glucose units joined together in a long chain with branches occurring about every 4–8 glucose units. Use the Internet or other resources to research the structure of glycogen. Draw the structure and use your research to assist you in constructing a model of glycogen.
  - a To the disaccharide in step 4 add a further three glucose units, making it a 5-glucose polymer in a linear chain.
  - b At the position of the fourth glucose unit, construct a branched chain made up of three glucose units.

### Discussion

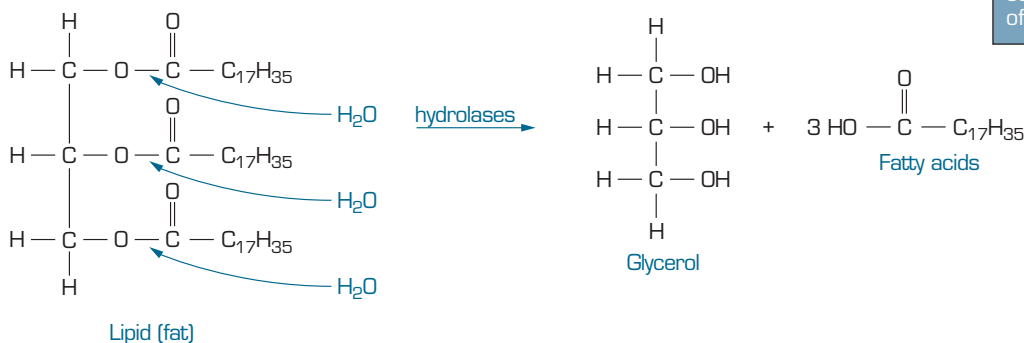
- 1 Which carbon atoms are involved in bond formation of the disaccharide in step 4 above? What is the product that is eliminated as a result of this reaction?
- 2 Which carbon atoms of glucose are involved in forming branched chain bonds in glycogen?
- 3 Identify the similarities and differences between the structures of glucose and glycogen molecules.

## Lipids

The term lipid describes the compounds such as fats, waxes and oils. Like carbohydrates, lipids consist of carbon, hydrogen and oxygen. Lipids are not soluble in water. Lipids are converted to fatty acids using a hydrolysis reaction.



Lipids are a group of compounds that consist of fats, waxes and oils.



**figure 16.17** Enzymes called hydrolases catalyse the conversion of lipids into fatty acids and glycerol.

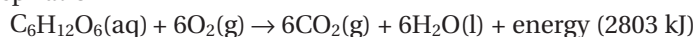


There are three types of fats: saturated, mono-unsaturated and poly-unsaturated. Saturated fats, such as palmitic acid ( $\text{CH}_3(\text{CH}_2)_{14}\text{COOH}$ ), contain only single carbon to carbon bonds and are regarded as unhealthy fats as they are easily converted to cholesterol in the body. Excessive production of cholesterol leads to hardening of the arterial walls. This is because cholesterol binds to the arteries reducing their elasticity and even forming blockages.

Monounsaturated fats, such as oleic acid ( $\text{CH}_3(\text{CH}_2)_7\text{CH}=\text{CH}(\text{CH}_2)_7\text{COOH}$ ), are very similar to saturated fats but contain a solitary double bond in their structure. This makes it difficult for the human body to convert it to cholesterol. Polyunsaturated fats, such as linoleic acid ( $\text{CH}_3(\text{CH}_2)_4\text{CH}=\text{CHCH}_2\text{CH}=\text{CH}(\text{CH}_2)_7\text{COOH}$ ) contain two or more double bonds in their structure. Polyunsaturated fats cannot be converted to cholesterol by the body. Monounsaturated and polyunsaturated fats are regarded as healthier fats by nutritionists.

Gram for gram, lipids metabolise to produce more energy than carbohydrates. However the process of converting lipids to energy is not as efficient and requires approximately twice as much oxygen to produce the same amount of energy as carbohydrates.

#### Respiration



1 g of sugar requires  $2.0 \times 10^{22}$  molecules of  $\text{O}_2$  and produces 15.5 kJ of energy.

#### Oxidation of a fatty acid

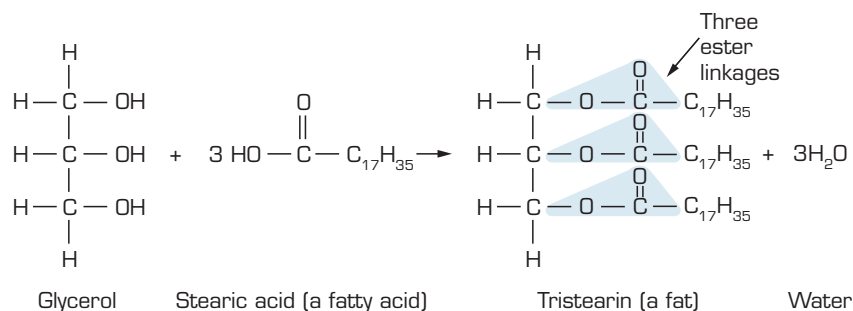


1 g of fat requires  $5.4 \times 10^{22}$  molecules of  $\text{O}_2$  and produces 38 kJ of energy.

Dieticians now recommend that you should reduce your intake of saturated fats, but include monounsaturated and polyunsaturated fats in your diet. Some fat in your diet is essential as they play an important dietary role. Vitamins A, D, E and K are fat-soluble vitamins that are present in fatty foods. Vitamin D and the hormones oestrogen and testosterone are manufactured by the body using the cholesterol molecule.

Waxes are found in both plants and animals. Waxes provide a waterproof coating for the leaves of plants to prevent moisture loss, and ducks have a waxy coating on their feathers to prevent them from absorbing too much water which affects their ability to swim on the surface or fly.

Fats and oils are formed when the compound glycerol reacts with three fatty acid molecules.



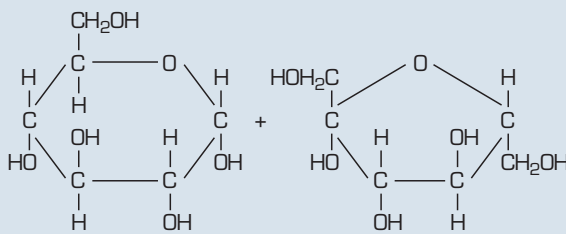
**figure 16.18** The reaction that forms triglycerides in our bodies.

The bond that links the fatty acids molecules to the glycerol molecule, is called an ester link ( $\text{R}-\text{COO}-\text{R}$ , see figure 16.18). This bond is broken when lipids are hydrolysed.



The synthesis reaction is a condensation reaction and the lipids produced are called triglycerides. The condensation reaction that forms triglycerides is catalysed by enzymes and coenzymes. Triglycerides can be easily stored by the body and be used for energy when required.

## Questions

- Glucose is described as a monosaccharide, maltose as a disaccharide and glycogen as a polysaccharide.
  - What is the difference between the three types of carbohydrates?
  - What type of reaction is involved in converting glucose to maltose and then to glycogen?
  - Which functional group in the molecules is involved in these reactions?
- Consider table 16.1, which shows the amino acids that make up proteins in the body. Some amino acids are essential to the human diet, whereas the body can manufacture others. With the aid of the information in the table:
  - draw the structural formulae of serine and cysteine
  - write an equation to show the formation of a dipeptide from these amino acids
  - name the type of reaction in part b.
- When alanine and glycine react, two different dipeptides can be formed.
  - Write the formula for each dipeptide.
  - How many tripeptides can be formed from three different amino acids?
  - Proteins are formed using 20 different amino acid units. Each protein can be thousands of amino acid units in length. On the basis of your answers to parts a and b, what can you say about the number of different proteins possible?
- Part of a protein is shown in figure 16.19.
- Scientists have spent many years trying to develop a form of the protein insulin that can be given to diabetics orally rather than by injection. Suggest an aspect of the chemistry of proteins that has so far prevented insulin from being taken orally.
- Enzymes are not the only proteins for which shape is important. The protein coat of a virus, the wave in your hair and the structure of haemoglobin are all made from proteins of a particular shape.
  - Explain what determines the shape of a protein.
  - What could happen to an enzyme if a mutation caused a change in the sequence of its amino acids? What effect would this have on the biochemical reaction catalysed by it?
  - Milk contains the protein casein. Why does milk curdle when vinegar is added to it?
- Condensation reactions are responsible for the formation of many important biomolecules, such as cellulose, proteins, starch, lipids. Draw the structure of the products of the following condensation reactions.
  - 

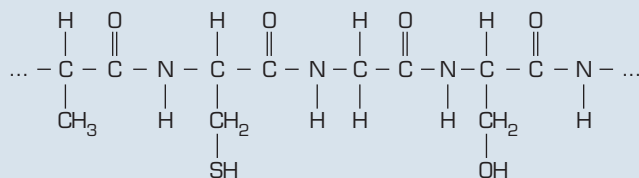
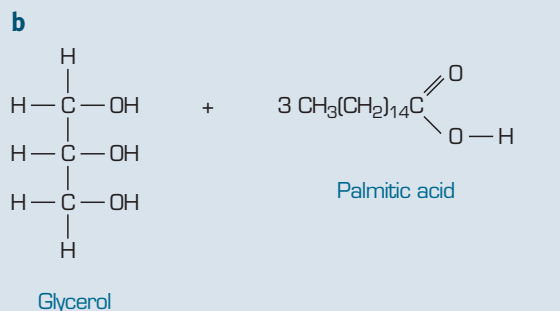


figure 16.19

- Circle the peptide linkages in this part of the protein chain.
- Write the formulae of the amino acids that made up this part of the chain.
- Where in the body does hydrolysis of proteins to form amino acids take place?



## 16.3 Matter cycles

Life's reactions require essential molecules such as oxygen, water, proteins, carbohydrates and lipids. Each essential compound is made of some essential elements. These elements exist in various forms throughout the earth, and can be acquired by organisms in a number of ways. Five of the most essential elements are carbon, oxygen, nitrogen, phosphorus and sulfur.

### The carbon cycle

Carbon is an essential element to all life. It is the base element for all organic compounds. Carbon cycles through the atmosphere, land and water continuously. Land-dwelling plants use atmospheric carbon dioxide and aquatic plants can extract dissolved carbon dioxide from the water in which they live. Plants use the carbon dioxide to create their own food in the form of the sugar glucose. Respiration releases carbon dioxide back into the atmosphere. Carbon can also be released back into the atmosphere by volcanoes, organic decay, forest fires or the combustion of coal oil or natural gas.

The carbon that is consumed by plants and animals forms the proteins and lipids that make up their cells. This carbon is released back into the environment after they die. The organisms that assist in this recycling are called decomposers (e.g. bacteria and fungi).

Some plants and animals become buried under layers of sedimentary rock after they die. Their carbon remains trapped in underground deposits and forms fossil fuels such as coal, oil and natural gas. In marine systems carbon can be trapped in limestone.

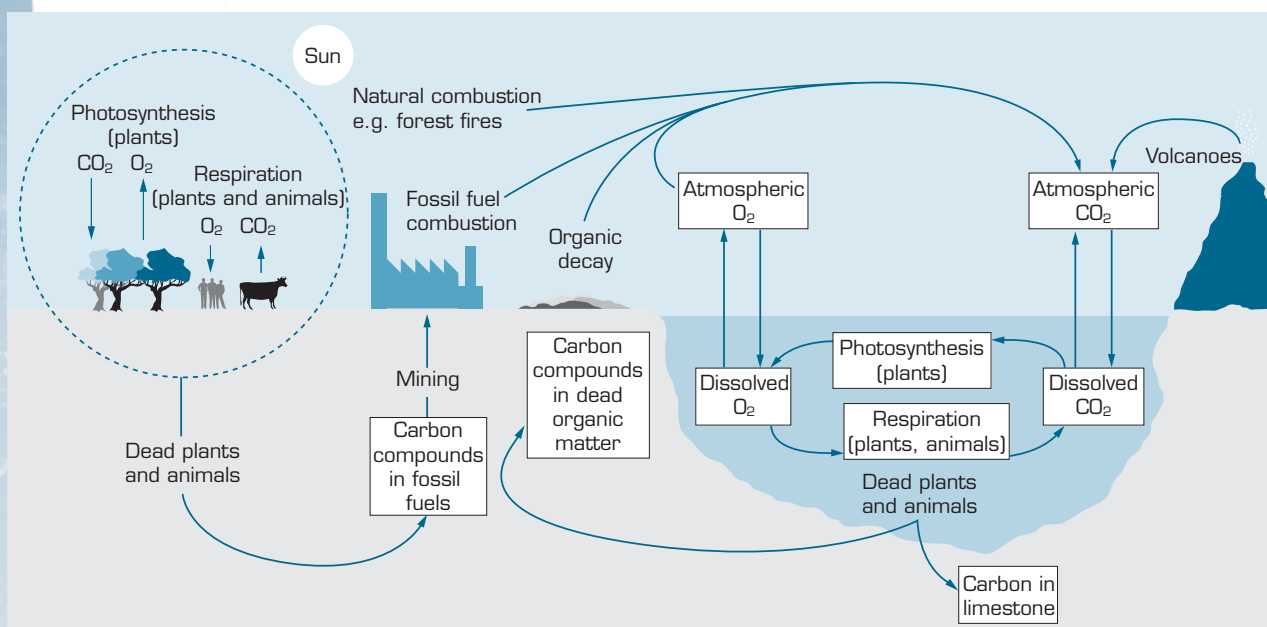


figure 16.20 The carbon cycle relies heavily on the presence of oxygen.

The element oxygen is closely linked to the carbon cycle. It is absorbed and released into the atmosphere during photosynthesis and respiration.

The cycling of oxygen is much more complicated because it is such a reactive element. Oxygen forms oxides with many different metals in the Earth's crust (e.g. iron oxide). It combines with nitrogen to form nitrates, sulfur to form sulfates, phosphorus to form phosphates, and is an essential component of water.

## The nitrogen cycle

Nitrogen is found in many essential organic compounds. Amino acids (the building blocks of proteins) and DNA (deoxyribonucleic acid) are two very important organic compounds that contain nitrogen.

Nitrogen gas is the major component of our atmosphere. Although our atmosphere is rich in nitrogen, plants cannot make use of it in the form  $N_2$ . Nitrogen gas is a very unreactive molecule due to the triple bond between nitrogen atoms. Plants rely on nitrogen-fixing bacteria to convert atmospheric nitrogen into ammonia ( $NH_3$ ) in the soil. Plants then draw their nitrogen from the soil. Nitrogen-fixing bacteria can be found in the soil or inside the root nodules of certain plants such as legumes and clover. The chemical process the bacteria use to convert nitrogen into ammonia is called **nitrogen fixation**. Ammonia can be used by the plants to manufacture their proteins.



**Nitrogen fixation** is the chemical process used by bacteria to convert nitrogen gas into ammonia.

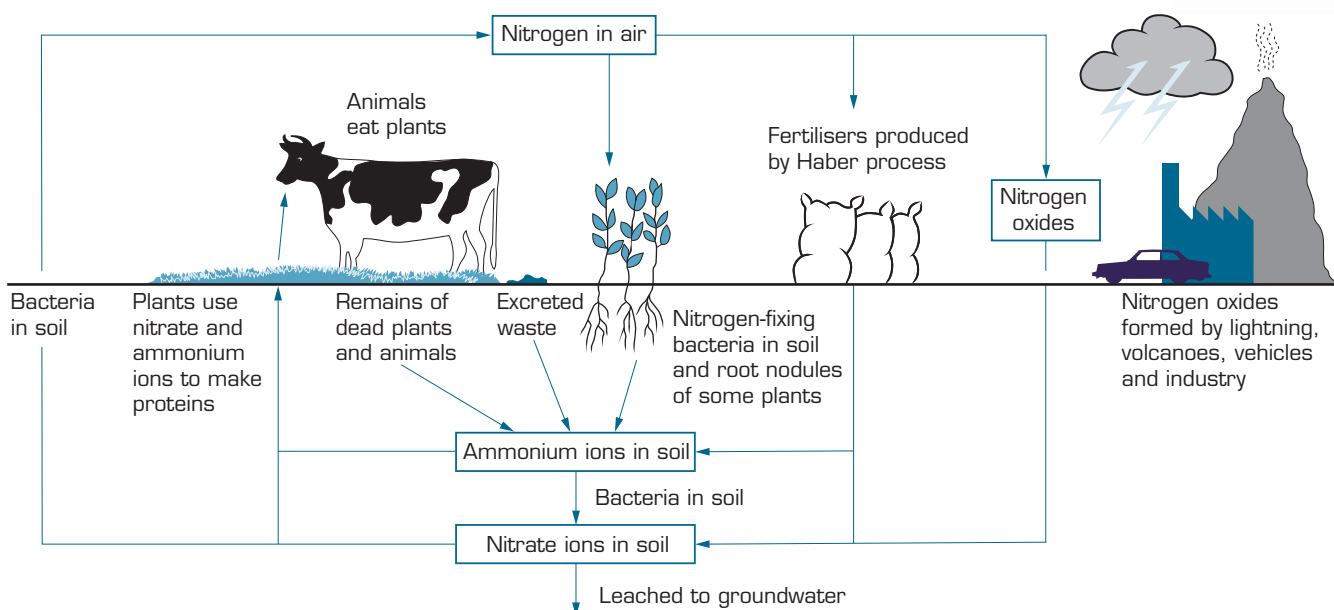


figure 16.21 The nitrogen cycle.

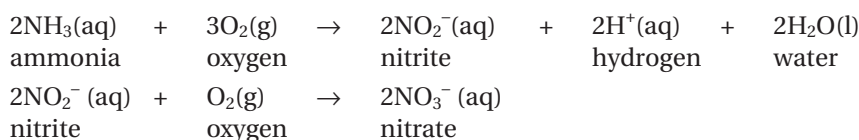


**Nitrification** is the chemical process by which bacteria convert ammonia into nitrates.



**figure 16.22** Plants such as legumes and clover have root nodules containing bacteria which can carry out nitrogen fixation for the plant.

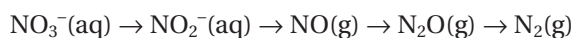
Plants can also use nitrogen in the form of nitrates ( $\text{NO}_3^-$ ). Ammonia is converted to nitrates in the soil by other bacteria using a process called **nitrification**. The nitrifying bacteria convert ammonia to nitrates using a two-step chemical process.



These chemical processes usually provide enough nitrogen for healthy plant life, however densely planted crops, such as sugar cane, remove large amounts of nitrogen from the soil—somewhere between 100–500 kg per hectare each year or approximately 5–10 times more than a naturally occurring forest. This creates nitrogen-deficient soils in which plants struggle to grow. For continued crop success farmers must replace the nitrogen by using fertilisers.

Plant and animal remains, and waste are also a source of soil nitrogen. Bacteria break down the plant and animal remains into ammonia. Lightning and bushfires also produce nitrogen oxides in our atmosphere. These nitrogen oxides fall onto the soil where they can be converted to nitrates and used by plants.

Nitrogen is cycled from the soil and back into the atmosphere by denitrifying bacteria. **Denitrification** occurs more rapidly in very moist soils and requires a number of steps.



The chemical processes of nitrogen fixation, nitrification and denitrification keep the atmospheric concentration of nitrogen stable.

## The phosphorus cycle

Phosphorus is a vital element in plants and animals because it is an essential component of DNA, certain plant and animal proteins, and bones and teeth. Phosphorus cycles through the soils, oceans and lakes of the Earth. Unlike carbon or nitrogen, there is no gaseous form of this element found in our atmosphere. Animals absorb phosphorus in the form of phosphates ( $\text{PO}_4^{3-}$  and  $\text{HPO}_4^{2-}$ ) by eating plants or herbivores.

Plants acquire their phosphates from the soil. Phosphates are incorporated back into the soil from the decomposition of plant and animal remains or wastes, or by the addition of fertilisers. Phosphorus forms phosphates  $\text{PO}_4^{3-}$  and  $\text{HPO}_4^{2-}$  in the soil which can be utilised by plants in protein synthesis to promote root growth and flowering.

**Denitrification** is the chemical process during which bacteria convert nitrates back into atmospheric nitrogen.

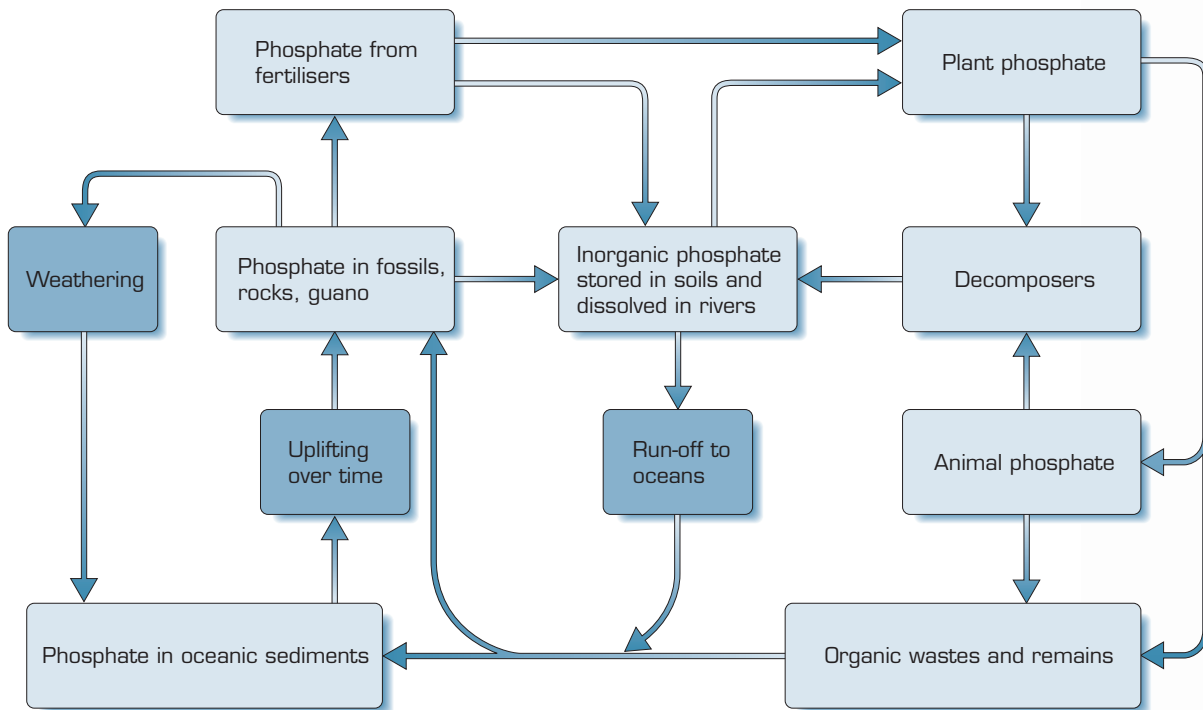


figure 16.23 The phosphorus cycle.

## The sulfur cycle

Sulfur is also an essential component of proteins and vitamins. Plants acquire sulfur from the soil. Animals acquire sulfur from eating plants or herbivores. Sulfur is released naturally by volcanic eruption ( $H_2S$ ) and microscopic marine algae in the form of dimethyl sulfide,  $(CH_3)_2S$ .

Sulfur is also released in our atmosphere because of human activity (e.g. the burning of coal). When some forms of coal are burned for heat and electricity it releases hydrogen sulfide ( $H_2S$ ) and sulfur dioxide ( $SO_2$ ) into the atmosphere.

Worksheet 3  
Matter cycles

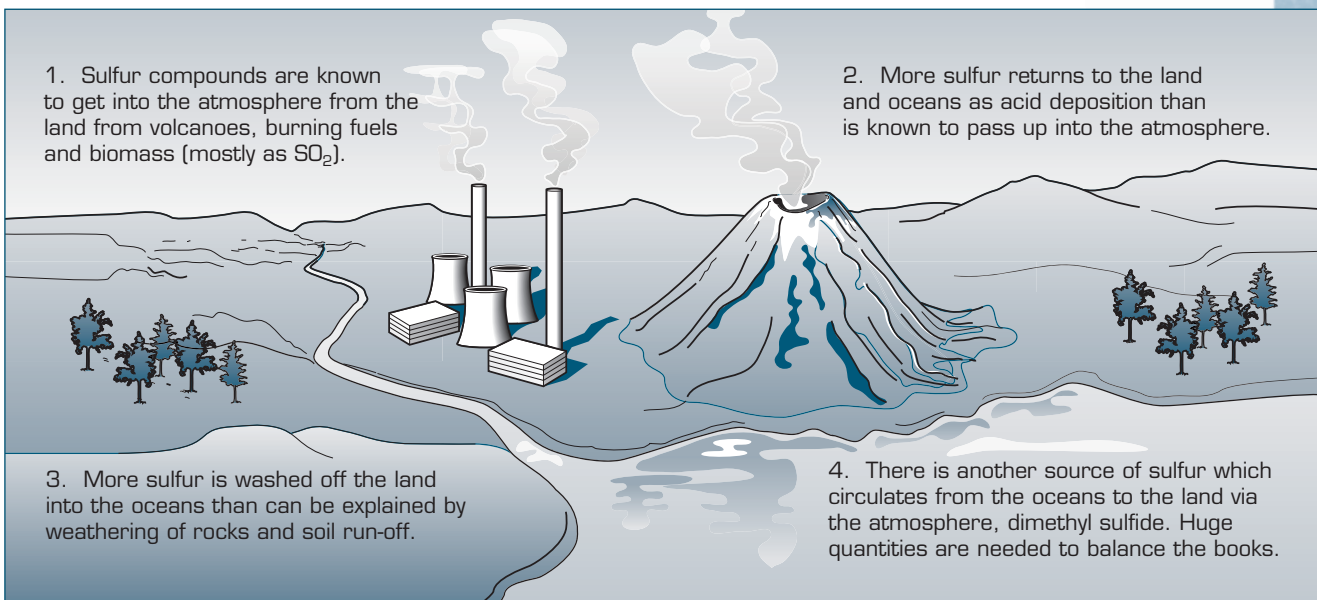


figure 16.24 The sulfur cycle.



## Questions

- 11 Consider the nitrogen cycle shown in figure 16.21. Describe the short-term effect of:
- decreasing the rate of fertiliser use
  - planting more nitrogen-fixing plants
  - sterilising the soil.
- 12
- Why is fruit often stored in an atmosphere of nitrogen?
  - In the nitrogen cycle, what is the role of plants?
  - Why are fertilisers used by farmers?
- 13 The incomplete diagram in figure 16.25 shows how nitrogen compounds are involved in the nitrogen cycle. Copy the diagram and write the names of the type of nitrogen compound found in each stage of the cycle in the empty boxes.

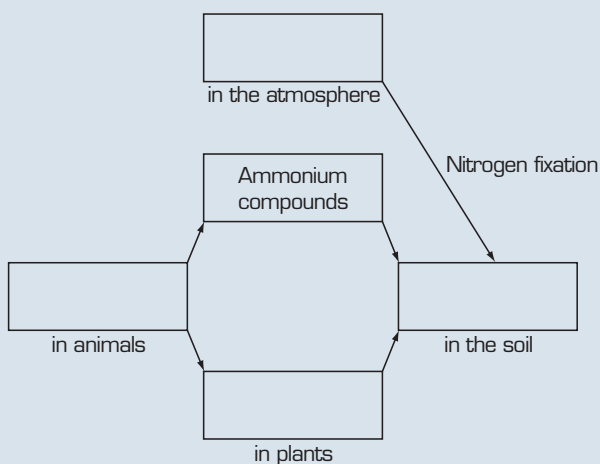


figure 16.25

- 14
- Describe the overall reactions and energy transformations that occur in photosynthesis and respiration.
  - Explain the roles of photosynthesis and respiration in the carbon–oxygen cycle.
- 15 Why is oxygen essential for the continuation of life on Earth?
- 16 Why is carbon dioxide essential for the continuation of life on Earth?
- 17
- Copy figure 16.26 of the carbon cycle, and draw arrows on the lines to show directions of movement of carbon dioxide.
  - Name each of the processes A–C.
  - Write equations for:
    - process A (assuming that glucose,  $C_6H_{12}O_6$ , is a product)
    - process B (assuming that glucose is a reactant)
    - process C (assuming that methane gas,  $CH_4$ , is burned).

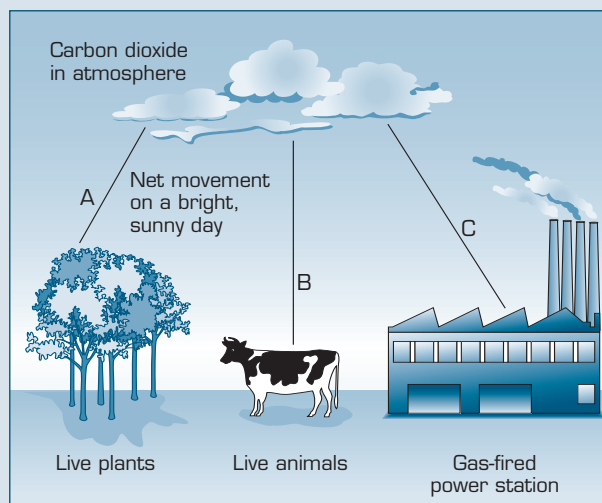


figure 16.26

- 18 Explain how each of the following will affect the carbon–oxygen cycle in the atmosphere:
- a bushfire that destroys a state forest
  - an increase in car sales
  - the development of a more fuel-efficient truck.
- 19 There is concern in the community about water pollution that is a result of phosphates being added to washing powders to improve their cleaning ability. The phosphorus in a 2.0 g sample of washing powder is precipitated as  $Mg_3P_2O_7$ . The precipitate weighs 0.085 g.
- What is the percentage, by mass, of phosphorus in the washing powder?
  - Suppose you were in charge of an advertising campaign to promote the washing powder. Would you advertise the percentage of phosphorus or phosphate in the product? Explain.
- 20 Sulfur dioxide is present in emissions from sulfuric acid plants.
- Why is the release of large amounts of sulfur dioxide in the atmosphere undesirable?
  - What is done to limit the extent of these emissions in sulfuric acid plants?
  - What other industries emit sulfur dioxide?

## Summary ▶▶▶▶

- ▶ **Photosynthesis** is a chemical process that requires sunlight to drive a chemical reaction between carbon dioxide and water, to produce glucose and oxygen. It is catalysed by **chlorophyll**, which is a green pigment found in plants and absorbs sunlight.
- ▶ **Respiration** is a chemical process during which oxygen reacts with glucose to produce carbon dioxide, water and energy.
- ▶ **Enzymes** are proteins that act as biological catalysts which increase the rate of biological reactions. A **substrate** is the reacting molecule to which the enzyme binds.
- ▶ **Hydrolysis** is the breaking of a covalent bond using a water molecule. **Hydrolases** are enzymes that catalyse hydrolysis reactions.
- ▶ **Proteins** are natural polymers made up of repeating units called **amino acids**. Amino acids are the monomers that make up protein molecules.
- ▶ A **peptide bond** joins amino acids together to form long polymers called proteins. A **peptide** is a chain made of two or more amino acids linked together.
- ▶ **Carbohydrates** are compounds that are used for energy by living organisms.
- ▶ **Lipids** are a group of compounds that consist of fats, waxes and oils.
- ▶ **Condensation reactions** are used by living organisms to form new proteins, carbohydrates and lipids. A condensation reaction involves the joining of two molecules with the release of a small molecule such as water.
- ▶ **Coenzymes** or vitamins act by activating the enzymes that catalyse a condensation reaction.
- ▶ Nitrogen is an important component of DNA and proteins. Nitrogen is recycled constantly by our environment. **Nitrogen fixation**, **nitrification** and **denitrification** are chemical processes that keep the concentration of nitrogen constant in our atmosphere.
- ▶ Carbon, oxygen, phosphorus and sulfur are other important elements that cycle through our environment.

## Key terms ▶▶

amino acids  
carbohydrate  
chlorophyll  
coenzymes  
condensation reaction

denitrification  
enzymes  
hydrolases  
hydrolysis  
lipid

nitrification  
nitrogen fixation  
peptide  
peptide bond  
photosynthesis

proteins  
respiration  
substrate



## Chapter Review

### 16.1 Reactions of life

- 21 The process by which carbon dioxide and water are converted to glucose and oxygen in plants is called:
- respiration.
  - nitrogen fixation.
  - combustion.
  - photosynthesis.
- 22 During the process of respiration:
- oxygen and water react to form carbon dioxide and glucose.
  - glucose and oxygen react to form carbon dioxide and water.
  - carbon dioxide and water react to form glucose and oxygen.
  - oxygen and carbon dioxide react to form glucose and water.
- 23 The overall reaction that occurs during respiration can be summarised as:
- $$\text{C}_6\text{H}_{12}\text{O}_6(\text{aq}) + 6\text{O}_2(\text{g}) \rightarrow 6\text{CO}_2(\text{g}) + 6\text{H}_2\text{O}(\text{l}); \Delta H = -2803 \text{ kJ mol}^{-1}$$
- Calculate the energy released by the digestion of 1.00 g of glucose.
  - What volume of water could be heated from 20.0°C to 37.0°C by the amount of energy released in part a?
  - Calculate the mass of glucose required to provide a daily energy supply of 12 MJ.
  - What volume of carbon dioxide, measured at STP, is produced during the production of 12 MJ of energy?
- 24 Glucose is produced by photosynthesis according to the following equation:
- $$6\text{CO}_2(\text{g}) + 6\text{H}_2\text{O}(\text{l}) \rightarrow \text{C}_6\text{H}_{12}\text{O}_6(\text{aq}) + 6\text{O}_2(\text{g}); \Delta H = +2803 \text{ kJ mol}^{-1}$$
- Write a thermochemical equation for the reaction of glucose with oxygen.
  - How much energy is released when 5.00 g of glucose is oxidised?

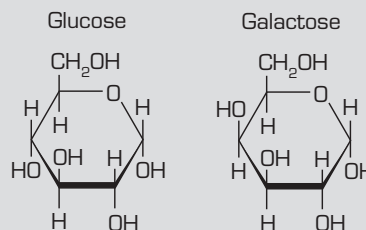
### 16.2 The chemistry of digestion

- 25 Protein molecules are formed by condensation reactions between amino acids. The secondary structure of many proteins is a helical shape. The type of chemical bond responsible for maintaining this shape is the:
- hydrogen bond.
  - ion-dipole bond.

- ionic bond.
- covalent bond.

- 26 Condensation reactions are responsible for the formation of many important biomolecules, such as cellulose, proteins, starch, lipids.

Draw the structure of the products of the condensation reaction between glucose and galactose.



- 27 Although fats provide nearly twice the energy of carbohydrates, they take longer to digest. Find out how this fact is related to the diet of endurance athletes such as marathon runners.

- 28 The structure of lactose is shown in the figure 16.27.

Lactose undergoes hydrolysis in the digestion process.

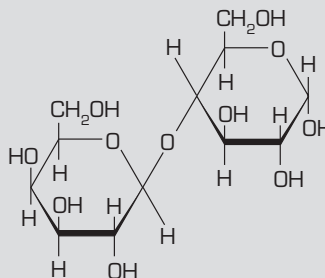


figure 16.27

- What is meant by the term hydrolysis?
  - Copy the structure of lactose and circle a hydroxy and an ether functional group in the molecule.
  - Draw the structures of the hydrolysis products.
- 29
- Explain the difference between condensation reactions and hydrolysis reactions.
  - What is the importance of these reactions in the human body?
  - Write equations for condensation reactions between:
    - two glucose molecules
    - a glycerol molecule and three molecules of palmitic acid ( $\text{CH}_3(\text{CH})_{14}\text{COOH}$ )
    - two alanine molecules.





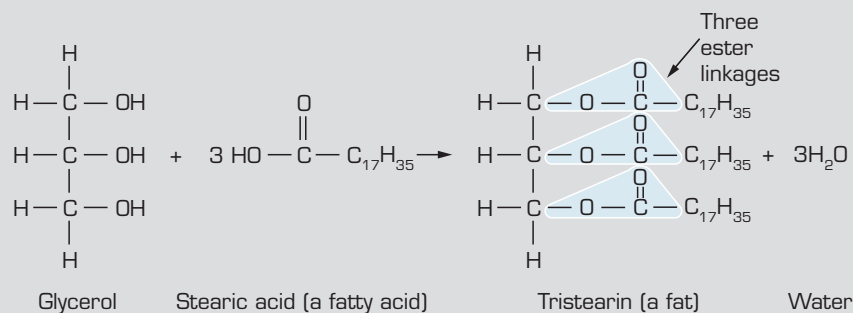


figure 16.28

- 30 By referring to figure 16.28, write an equation that shows the hydrolysis of the fat tristearin.

### 16.3 Matter cycles

- 31 Which of the following do not occur during the carbon cycle?
- A Oxygen is removed from the atmosphere by the process of combustion.
  - B Carbon dioxide is removed from the atmosphere by the process of photosynthesis.
  - C Carbon dioxide is added to the atmosphere by the process of respiration.
  - D Oxygen is added to the atmosphere by the process of decomposition.
- 32 The two flow diagrams represent two different parts of the carbon cycle.
- Starch  $\xrightarrow{\text{W}}$  Glucose  $\xrightarrow{\text{X}}$  Carbon dioxide
- Carbon dioxide  $\xrightarrow{\text{Y}}$  Glucose  $\xrightarrow{\text{Z}}$  Starch
- The processes represented by W, X, Y and Z are:
- A condensation, photosynthesis, respiration, hydrolysis.
  - B hydrolysis, photosynthesis, respiration, condensation.
  - C condensation, respiration, photosynthesis, hydrolysis.
  - D hydrolysis, respiration, photosynthesis, condensation.
- 33 The two flow diagrams represent two different parts of the carbon cycle.
- Starch  $\xrightarrow{\text{W}}$  Glucose  $\xrightarrow{\text{X}}$  Carbon dioxide
- Carbon dioxide  $\xrightarrow{\text{Y}}$  Glucose  $\xrightarrow{\text{Z}}$  Starch
- The two reactions in which water is a reactant are:
- A W and Y.
  - B X and Z.
  - C W and Z.
  - D X and Y.

# 17

## Reversible reactions

### 17.1 Reversible reactions

What makes a reaction proceed? We often presume when we write a chemical equation that the reactants will react completely to form the specified products. Is this always so?

Consider the following situation. If you add a small amount of common salt, NaCl, to a beaker of water, it will dissolve readily. This process can be written as



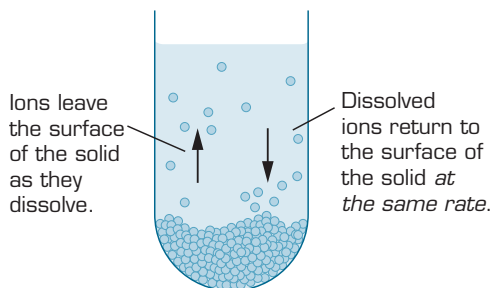
In solid sodium chloride, sodium ions and chloride ions are held in a lattice. As the solid dissolves, the ions **dissociate**, or separate from each other. They are **hydrated**, or surrounded by water molecules. The attraction between the water molecules and the ions help it to dissolve.

Will this process always occur? If you add a salt to water, it will readily dissolve. If you continue to add more salt to the solution, you will reach a point where no more solid appears to be dissolving. When a solution can not dissolve any more solute it is described as **saturated**.

In fact, if we could examine this system at the particle level, we would discover that sodium chloride is continuing to dissolve. However, it is also recrystallising at the same rate (figure 17.1). The two processes proceed at the same rate and there is no change in the amount of solid or the concentration of ions in the solution. The process appears to have stopped.

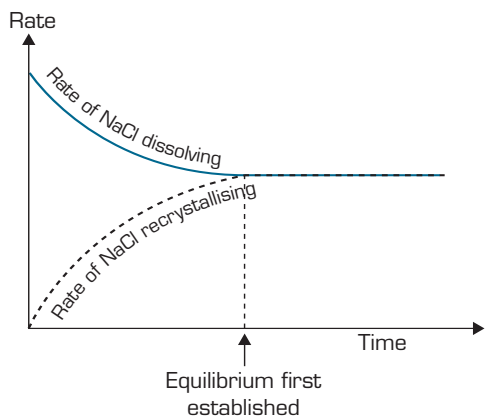
**Dissociation** is the process by which a solid ionic compound separates into its ions in solution.

**Hydration** is the process by which water molecules surround and interact with solute ions or molecules.



**figure 17.1** Sodium chloride continues to dissolve, but it also recrystallises at the same rate.

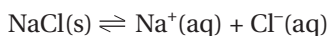
Figure 17.2 shows that the rates of both the forward process and the reverse process vary during the course of the reaction. Initially, the rate of dissolving is high. As the amount and surface area of the remaining solid decreases, so does the rate of dissolving. The rate of recrystallising is zero to begin with. As there are no ions in the solution, this process does not occur. As dissolving continues, the concentration of ions increases. Ions already in the solution have a greater chance of colliding with the solid crystals; some of these will recrystallise. The rate of recrystallisation increases. Eventually, the rate of recrystallising is the same as the rate of dissolving.



**figure 17.2** The rates of the forward and reverse processes for sodium chloride in water.

A salt dissolving in water is said to be a **reversible reaction**. A reversible reaction is one that can be made to go in either direction, forward or reverse. When the rates of the forward and reverse reactions are equal, the reaction is said to be in **dynamic equilibrium**, or **equilibrium**. The appearance of an equilibrium mixture does not change. 'Dynamic' tells us that the forward and reverse reactions continue to occur; 'equilibrium' indicates that no further change in concentrations takes place, so the forward and reverse reactions are occurring at the same rate. These terms can only be applied to a closed system, i.e. a system to which reactants, products or energy, such as heat or light, are not added or removed. If conditions are changed, the equilibrium position will shift.

The equation for the dissolving of salt can be rewritten as:



The two arrows show that the process can proceed in either direction, and can achieve equilibrium at specified conditions.

Contrast this to a **steady state system** in which reactants are continually added and products are removed at the rate at which they form. A lit Bunsen burner is an example of this. The flame is steady and stable, but reactants are continually supplied and products, including heat, leave. Although concentrations are constant, it is not a closed system and is not at equilibrium. The rates of the forward and reverse reactions are not equal. The rate of formation of product is greater than if the reaction was allowed to come to equilibrium.

A reversible reaction can be made to proceed in either direction.

**Equilibrium** exists in a closed system when two opposing reactions occur at the same time and same rate. Equilibrium is dynamic as both reactions continue to occur.

A **steady state system** has concentrations which are constant, but it is not at equilibrium. The rates of the forward and reverse reactions are not equal.





**figure 17.3** In a steady state process, reactants are added and products are removed at the same rate.

## Position of equilibrium

The **position of equilibrium** refers to a particular set of equilibrium concentrations for a reaction. For all but the simplest systems, there may be many sets of concentrations of the various reactants and products which represent equilibrium conditions.

Although the rates of the forward and reverse reactions are equal, the concentrations of the reactants almost never equal the concentrations of the products at equilibrium. If a small amount of product has formed when equilibrium is reached, we say that the position of equilibrium lies to the left. If a high proportion of reactants have reacted to form products, we say that the position of equilibrium lies to the right.

When equilibrium is reached, it is impossible to determine whether the starting materials were the reactants or products. The position of equilibrium will be the same. Consider the reaction

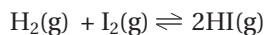
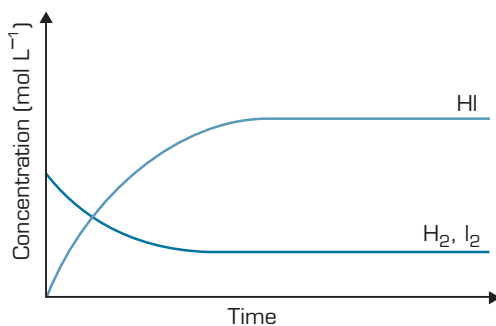
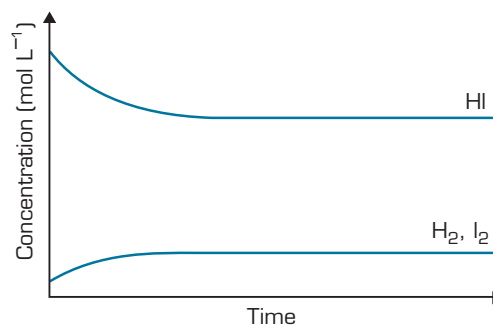


Figure 17.4(a) shows a concentration–time graph with  $\text{H}_2$  and  $\text{I}_2$  as the starting materials. Figure 17.4(b) shows a similar graph for which the reaction started with the product, HI, and formed  $\text{H}_2$  and  $\text{I}_2$ . The initial mixture cannot be determined from the final concentrations of the reactants and products.



A mixture of pure hydrogen and iodine reaches equilibrium.



Hydrogen iodide decomposes to hydrogen and iodine at the same temperature.

**figure 17.4** Equilibrium can be reached by starting with either reactants or products. The reaction mixture in both cases is the same.

The **position of equilibrium** is a set of equilibrium concentrations for a reaction.

The double arrow is used to indicate that the reaction is reversible and can reach equilibrium.

## Driving forces of a reaction

What factors cause some reactions to be reversible? When heated with a lit match, gas burns spontaneously to completion. Even when cooled, it does not reform into reactants. This is not a reversible reaction. Yet ice melts when taken out of the freezer and freezes again when cooled. Clearly, this process is reversible, like the dissolving of salt above.

There are two factors, or driving forces, to be considered in deciding if a reaction will occur. The first is that reactions tend to proceed in the direction leading to lower enthalpy. The second is that reactions tend to proceed in the direction that will cause an increase in entropy.

The following examples will illustrate how these two driving forces work together for some reactions and, for others, they oppose each other. These examples illustrate the conditions and results from table 11.5.



### Worked example 17.1A

Combustion of octane:  $\Delta S$  is positive,  $\Delta H$  is negative.

The equation for this reaction is



This reaction is exothermic; the products have a lower enthalpy than the reactants. The driving force of lower enthalpy favours the forward reaction.

The products consist of a mixture of 34 mol of two different gaseous compounds. This is more random than the reactants which consist of 25 mol of a gaseous element and 2 moles of a liquid. Thus the driving force to greater entropy also favours the products. This reaction is spontaneous.

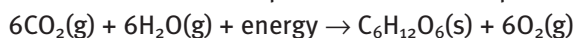
Knowing a reaction is spontaneous does not give us any information about the rate of the reaction. The reaction above does not normally occur at room temperature. This is because the activation energy is extremely high. Heat provided by a match or a spark will provide the necessary activation energy, and allow the reaction to proceed spontaneously as predicted. Provided sufficient oxygen is supplied and particles have the required activation energy, the reaction will proceed to completion. It does not reach a state of equilibrium.



### Worked example 17.1B

Photosynthesis:  $\Delta S$  is negative,  $\Delta H$  is positive.

This reaction occurs in plants and can be represented by the equation



As this reaction is endothermic, the lower enthalpy of the reactants tends to drive this reaction in the reverse direction. The reverse reaction also causes an increase in entropy. So both driving forces indicate the reverse reaction will be spontaneous and the forward reaction will be non-spontaneous. It can occur only because a suitable energy source such as light is supplied.



Enthalpy is the heat content of a system. Entropy is a measure of the randomness or disorder of a system.



A negative  $\Delta H$  or  $\Delta S$  indicates this quantity has decreased.

A positive  $\Delta H$  or  $\Delta S$  indicates it has increased.

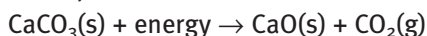




## Worked example 17.1C

Decomposition of limestone to make lime:  $\Delta S$  is positive,  $\Delta H$  is positive.

The equation for this reaction is



As this reaction is endothermic, the lower enthalpy of the reactants drives this reaction in the reverse direction. However, the products of this reaction have greater entropy than the reactants. This drives the reaction in the forward direction. These driving forces oppose each other, and the reaction is reversible.

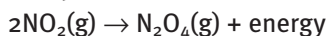
For reversible reactions, the conditions dictate whether the reactants or the products will be favoured. At low temperatures, the enthalpy change for the reaction in the example above is more significant and reactants are favoured. When heated, the enthalpy change is less significant, and the limestone decomposes. Under some conditions, the tendency to form one rather than the other may not be large. The reaction will reach equilibrium.



## Worked example 17.1D

The combination of  $\text{NO}_2$  molecules:  $\Delta S$  is negative,  $\Delta H$  is negative.

This process can be written as



In this case, the tendency to lower enthalpy of the products drives the reaction in the forward direction. The tendency to greater entropy drives the reaction in reverse. At higher temperatures, the reverse reaction (decomposition) predominates. When the mixture is cooled, more  $\text{NO}_2$  molecules combine to form  $\text{N}_2\text{O}_4$ . The reaction is reversible. The forward and reverse reactions will take place simultaneously, and the mixture will be able to come to equilibrium. The equilibrium position will depend on the temperature.

## Reaction rate and equilibrium

The rate of a reaction depends on the activation energy for that reaction. A reaction may proceed to equilibrium rapidly or slowly. The position of equilibrium is not affected by the reaction rate. We often want reactions to proceed rapidly, yet as a reaction approaches equilibrium, the rate decreases. Processes in industry and living systems are often designed to take place as steady state processes, far from equilibrium conditions. This maximises the rate of reaction. Equilibrium can be an undesirable situation, for example when batteries go flat. It is important to understand the behaviour of reversible reactions and systems at equilibrium.

### Worksheet 1

Reversible reactions I

## Questions

- For each of the reactions in the table, decide if enthalpy and entropy increase or decrease, and whether the reaction is spontaneous, non-spontaneous or reversible. The first one has been completed for you.
- The last reaction in Question 1 represents the combustion of propane, used as LPG. This fuel is used in barbecues and also in Bunsen burners. If there is a gas leak, and this gas mixes with air, it does not react, unless it is heated with a match or a spark. This is despite the fact that it is spontaneous. Explain.

Reaction	Enthalpy	Entropy	Type
$\text{NH}_3(\text{g}) + \text{HCl}(\text{g}) \rightarrow \text{NH}_4\text{Cl}(\text{s}) + 176 \text{ kJ}$	decreases	decreases	reversible
<b>a</b> $\text{C}(\text{s}) + \text{H}_2\text{O}(\text{g}) + 129.6 \text{ kJ} \rightarrow \text{CO}(\text{g}) + \text{H}_2(\text{g})$			
<b>b</b> $\text{H}_2(\text{g}) + \frac{1}{2}\text{O}_2(\text{g}) \rightarrow \text{H}_2\text{O}(\text{l}) + 286 \text{ kJ}$			
<b>c</b> $\text{FeO}(\text{s}) + \text{H}_2(\text{g}) + 22 \text{ kJ} \rightarrow \text{Fe}(\text{s}) + \text{H}_2\text{O}(\text{l})$			
<b>d</b> $\text{N}_2(\text{g}) + 3\text{H}_2(\text{g}) \rightarrow 2\text{NH}_3(\text{g}) + 92 \text{ kJ}$			
<b>e</b> $4\text{NH}_3(\text{g}) + 5\text{O}_2(\text{g}) \rightarrow 6\text{H}_2\text{O}(\text{g}) + 4\text{NO}(\text{g}) + 1166 \text{ kJ}$			
<b>f</b> $\text{Ca}(\text{s}) + \frac{1}{2}\text{O}_2(\text{g}) \rightarrow \text{CaO}(\text{s}) + 635.2 \text{ kJ}$			
<b>g</b> $\text{C}_3\text{H}_8(\text{g}) + 5\text{O}_2(\text{g}) \rightarrow 3\text{CO}_2(\text{g}) + 4\text{H}_2\text{O}(\text{g}) + 2220 \text{ kJ}$			

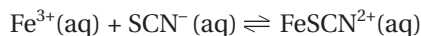
## 17.2 Le Chatelier's Principle

Henri Le Chatelier studied systems at equilibrium. In 1888 he proposed the statement known as **Le Chatelier's Principle**. If a change is applied to a system at equilibrium, the system reacts in such a way as to partially (or fully) counteract the change, in order to return to equilibrium. For reactions occurring in the same phase (homogeneous reactions), the changes are partially counteracted; for reactions occurring in different phases (heterogeneous reactions), the changes will be fully counteracted if there are sufficient reactants.

The change could be an increase or decrease in the concentration of one of the reactants or products, or an increase or decrease in the temperature. For gaseous substances, the change may also be an increase or decrease in the pressure. The addition of a solid reactant or product that appears in the equation has no effect on the equilibrium position.

### Changing concentration

The effect of altering the concentrations in a system at equilibrium can be studied using the following reaction.



This reaction has two advantages. It proceeds rapidly and the progress of the reaction can be easily monitored as the  $\text{FeSCN}^{2+}$  ion is a distinctive deep red colour. Changes in the intensity of the colour can be used to determine which way the reaction is proceeding.



# Experiment 17.1

## Concentration changes and equilibrium

### materials

- 0.20 M iron(III) nitrate,  $\text{Fe}(\text{NO}_3)_3$
- 0.002 M potassium thiocyanate, KSCN
- 50 mL beaker
- 100 mL measuring cylinder
- stirring rod
- 4 Petri dishes
- white paper
- solid potassium thiocyanate, KSCN
- solid sodium chloride, NaCl
- spatula

### safety

- Wear safety glasses and a laboratory coat for this experiment.
- Avoid contact of KSCN with skin and eyes. Do not swallow.

### Purpose

To study the effect changing concentration will have on a system at equilibrium.

### Method

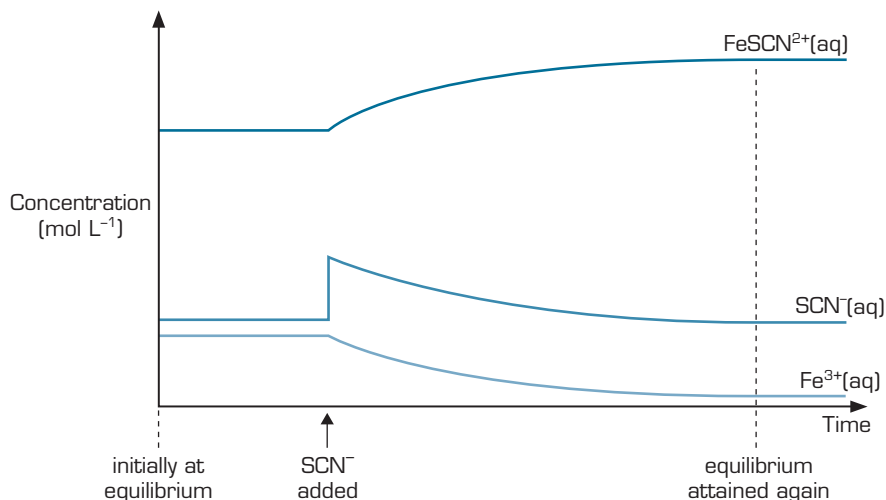
- 1 Measure 25 mL of KSCN solution and pour it into the beaker.
- 2 Add 5–6 drops of the iron(III) nitrate solution to the beaker, and stir until the colour is even throughout.
- 3 Place the Petri dishes on the white paper. Label the dishes 1–4. Pour equal depths of the mixture into each Petri dish.
- 4 The first dish is left as a control, for comparison. To the second dish, add a few crystals of potassium thiocyanate. To the third dish, add several drops of iron(III) nitrate solution. To the fourth dish, add a small sample of sodium chloride. Stir the mixture in each dish.
- 5 Compare the colour intensity in each dish with the control. Record your observations.

### Discussion

- 1 What evidence do you have that the reaction had reached equilibrium, before alterations were made?
- 2 Various substances were added to the Petri dishes. In which of the Petri dishes did the colour intensify?
- 3 What does this tell you about the direction of the reaction, in those dishes?
- 4 Relate this change to Le Chatelier's Principle.
- 5 In the fourth dish, sodium chloride was added. Chloride ions react with  $\text{Fe}^{3+}$  ions, reducing the concentration of those ions in the solution. Explain the changes that occurred, in terms of Le Chatelier's Principle.

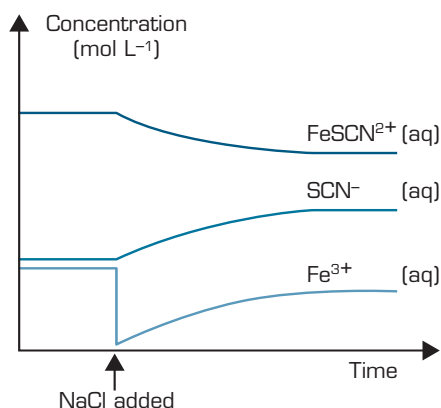
The system above was at equilibrium, as shown by the rapid reaction to form the deeply coloured  $\text{FeSCN}^{2+}$  ion, and the subsequent unchanging concentration of this colour. Changes were then made to concentrations of the products and reactants. When extra iron(III) nitrate was added, the concentration of  $\text{Fe}^{3+}$  increased and the system was no longer at equilibrium. To return to equilibrium, the reaction proceeded in the forward direction. This partly counteracts the increase in the concentration of the  $\text{Fe}^{3+}$ . Similarly, the addition of KSCN increased the concentration of  $\text{SCN}^-$ , driving the reaction in the forward direction, until a new equilibrium was reached. This is shown graphically in figure 17.5. Higher concentrations of the  $\text{FeSCN}^{2+}$  ion on the graph correspond to a more intense red colour in the experiment.





**figure 17.5** This graph shows the concentration changes when potassium thiocyanate is added to an equilibrium mixture of  $\text{Fe}^{3+}$ ,  $\text{SCN}^-$  and  $\text{FeSCN}^{2+}$ . Note that the added  $\text{SCN}^-$  is only partly removed when the mixture reaches a new equilibrium position.

When sodium chloride is added, chloride ions react with  $\text{Fe}^{3+}$  ions, reducing their concentration. To return to equilibrium, the reaction proceeds in the reverse direction, to partly restore the concentration of  $\text{Fe}^{3+}$ . The concentration of  $\text{FeSCN}^{2+}$  drops and the colour of the solution is less intense. This is shown in figure 17.6.



**figure 17.6** A graph of concentration, showing the changes after the concentration of  $\text{Fe}^{3+}$  is decreased.

## Changing temperature

Temperature changes alter the position of equilibrium. To see why this is so, you need to recall that reactions are associated with the release or absorption of energy. Essentially, energy is a reactant in endothermic reactions, and a product in exothermic reactions.

Consider the endothermic process for the formation of water vapour.



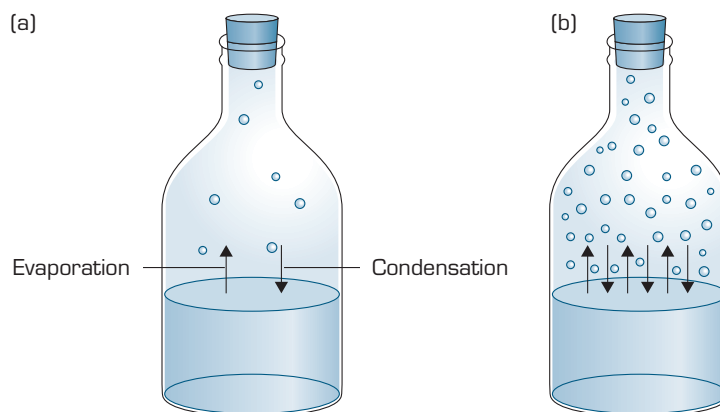
In a sealed container of water, the air above the water reaches a saturated state. When it is holding as much vapour as possible, the system is in equilibrium. Increasing the temperature adds energy to the system. The reaction proceeds in the direction that will use some of the added energy, i.e. the forward direction. More of the liquid evaporates, until a new equilibrium is reached. If there is insufficient liquid water in the container, a new equilibrium will not be reached.



$\Delta H$  is positive for an endothermic reaction.  
 $\Delta H$  is negative for an exothermic reaction.



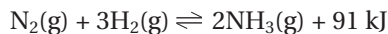
The effect of temperature change will be demonstrated in Experiment 17.2.



**figure 17.7** (a) The liquid–vapour equilibrium at a low temperature. (b) The liquid–vapour equilibrium at a higher temperature. The concentration of vapour, and the rates of evaporation and condensation are all greater at the higher temperature.

## Changing pressure of a gas system

The equation below shows an important industrial process, the Haber Process. It is used to make ammonia, which is subsequently used as a raw product for fertilisers and explosives.



In this case, all of the reactants and products are gases and pressure changes affect equilibrium.

Assuming the system has reached equilibrium, consider the effect of an increase in pressure. Le Chatelier's Principle predicts that the reaction will partially counteract the change to return to equilibrium. If the pressure is increased, fewer moles of gas will be the favoured position. In this reaction, 4 moles of gas react to form 2 moles of gas. The reaction will proceed in the forward direction until a new equilibrium is reached. Higher pressure favours the formation of products in this case; lowering the pressure favours the reactants in this reaction.

How does pressure influence equilibrium when only some of the substances are gases? An example of this is the evaporation of water.



Often, water and its vapour are not at equilibrium; more water can evaporate into the surrounding air. In an enclosed space, the vapour pressure will reach equilibrium with liquid water as shown in figure 17.8.

If the piston on the container is pushed in, the vapour pressure increases, and the reaction is no longer at equilibrium. To return to equilibrium, the increased pressure must be lowered. The reverse reaction increases and more vapour condenses, until the equilibrium is restored.

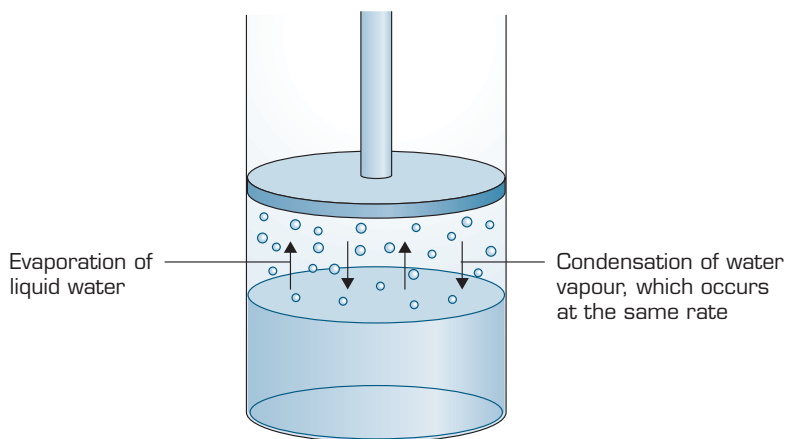
If the piston in the container is pulled out further, more water must evaporate, until equilibrium is restored. If there is not enough liquid water to do this, equilibrium may never be restored.

In the reaction below, you will have the opportunity to see how temperature and pressure affects a reaction between gases. The reaction to be studied is the decomposition of dinitrogen tetroxide. Like other decomposition reactions, it is endothermic.

Lowering the total number of moles of gas lowers the pressure.

The numbers of moles quoted refer to the stoichiometry of the reaction. It does not give equilibrium quantities.

In heterogeneous mixtures, equilibrium may not be able to be restored if a reactant runs out.



**figure 17.8** When the rate of evaporation and rate of condensation are equal, the vapour is in equilibrium with the liquid.



Dinitrogen tetroxide is colourless, while nitrogen dioxide is brown. The formation or disappearance of  $\text{NO}_2$  can be observed through changes in the intensity of the brown colour. Students should watch closely when the pressure is changed, as there is a change caused by the immediate pressure increase or decrease, and a more gradual change as equilibrium is restored.

## Experiment 17.2

### Demonstration of the effect of temperature and pressure on $\text{N}_2\text{O}_4$ – $\text{NO}_2$ equilibrium

#### Purpose

To study the effect of changing the temperature and changing the pressure of a system at equilibrium.

#### Method

- 1 In the fume cupboard, place a few scraps of copper in each flask. Add 30 mL of nitric acid. Stopper the flask immediately.
- 2 Prepare a hot water bath and an ice bath in the ice-cream containers.
- 3 As soon as the reaction has produced a fair amount of gas, take the syringe and fill it with gas from one flask. Do this quickly and replace the stopper. Take care while the flask is unstoppered. Cover the open end of the syringe, with cling wrap and a finger held firmly.
- 4 Place a flask in each temperature bath, and leave.
- 5 Connect the syringe to the electronic pressure probe, if available. Compress the gas in the syringe. Watch as equilibrium is restored. Record observations of colour and pressure changes.
- 6 Expand the gas in the syringe. Again observe and record any colour changes. Steps 5 and 6 can be done several times before the gas is disposed of in the fume cupboard.
- 7 Inspect the flasks. Observe and record colours of each.
- 8 Dispose of all gas in the fume cupboard when complete.

#### materials

- 3 M nitric acid,  $\text{HNO}_3$
- small pieces of copper, Cu
- measuring cylinder
- 2 large round bottomed flasks
- 2 stoppers to fit
- 2 ice-cream containers or similar
- ice
- hot water
- syringe without hypodermic needle
- cling wrap
- electronic pressure probe, if available



563

Reversible reactions



17



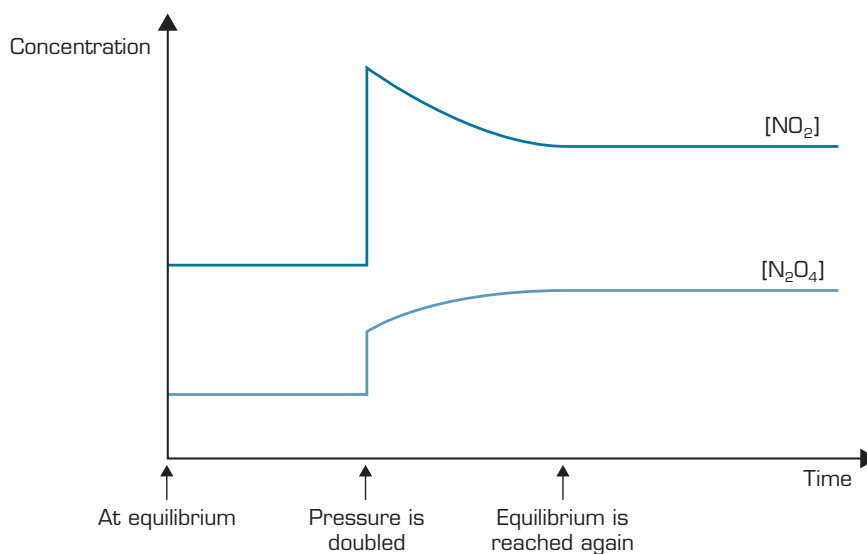
## safety

- This reaction should be carried out in a fume cupboard.
- This reaction is a demonstration. It is not suitable for groups of students to carry out. The demonstrator should wear safety glasses and a laboratory coat or acid-proof apron.

## Discussion

- 1 When the gas was compressed, two colour changes occurred. Explain, in terms of concentration and compression, the initial colour change. Use Le Chatelier's Principle to explain the subsequent change of colour. If pressure data is available, relate this to Le Chatelier's Principle also.
- 2 Why did the expansion of the mixture cause the colour of the mixture to gradually darken?
- 3 Use Le Chatelier's Principle to explain the behaviour on heating and cooling. Relate this to the endothermic process.

The graph in figure 17.9 shows how increases and decreases in the total pressure affect the equilibrium position. A doubling of total pressure doubles the pressure of each gas. To restore equilibrium, the pressure must decrease if possible. This is achieved, in this example, as the reaction proceeds in the reverse direction.



**figure 17.9** The graph shows that if pressure is increased, this reaction proceeds in reverse in order to return to equilibrium. If the pressure is decreased, this reaction proceeds in the forward direction to return to equilibrium.

## Adding a solid reactant or a pure liquid reactant to a system at equilibrium

Recall the reaction considered at the start of this chapter, the dissolution of solid sodium chloride. For reactions that contain one reactant in the solid state, addition of larger amount of solid, beyond what can react at equilibrium, does not change the position of equilibrium. This idea is true for solids in all reactions, and also applies for pure liquid reactants.

## Experiment 17.3

### Dissolving copper chloride

#### Purpose

To observe the effect of solid reactants on equilibrium.

#### Method

- 1 Add water to a depth of 1 cm to each beaker.
- 2 Add copper chloride to the water in each beaker, 1 teaspoon at a time. Stir after each addition, until definitely no more will dissolve. Record the amount of solid present. Observe the intensity of the colour of each solution.
- 3 Add another teaspoon of solid copper chloride to one of the beakers and stir again. Compare the intensity of the colour of the two solutions. Record your observations of the amount of solid now remaining in each beaker.

#### Discussion

- 1 When no more solute will dissolve in a solution, the solution is described as saturated. What did you notice about the intensity of the colour of each solution once it was saturated? Explain.
- 2 Explain what is happening inside the beakers, in terms of dissolving and recrystallising.
- 3 What can be said about the concentration of the saturated solutions? Explain.

#### materials

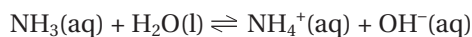
- two 50 mL beakers
- teaspoon
- water
- solid copper(II) chloride,  $\text{CuCl}_2$
- stirring rod

#### safety

- Wear safety glasses and a laboratory coat for this experiment.
- Wash hands thoroughly after the experiment.

In the case of the equilibrium between water and its vapour, addition of more liquid water to the system will not alter the equilibrium vapour pressure.

Water is also often both reactant and a solvent in other systems, such as the one below.



The concentrations of the other reactants in this system are far lower than the concentration of water. As water is the solvent, for all practical purposes, the change in its concentration is negligible; addition of water does not essentially alter its concentration. The effects of the concentration of liquid solvents like this can be ignored when considering equilibrium.

The volume of water will change the concentrations of the other ions, and there may be a compensating shift in their concentrations, but the overall concentration of the water will be essentially constant throughout.



## Questions

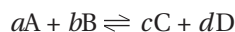
- 3 Look at the mole ratio in the equation for the reaction graphed in figure 17.5. How do concentrations of ions increase and decrease following the addition of potassium thiocyanate? Relate the size of the increases and decreases to the mole ratio of reactants and products in the equation.
- 4 Consider the situation if the reversible reaction below has reached equilibrium.  
 $2\text{CrO}_4^{2-}(\text{aq}) + 2\text{H}^+(\text{aq}) \rightleftharpoons \text{Cr}_2\text{O}_7^{2-}(\text{aq}) + \text{H}_2\text{O}(\text{l})$   
Chromate ions ( $\text{CrO}_4^{2-}$ ) are yellow, dichromate ions ( $\text{Cr}_2\text{O}_7^{2-}$ ) are orange and hydrogen ions ( $\text{H}^+$ ) are colourless.
- What will happen to the colour if more acid solution, containing  $\text{H}^+$ , is added? Explain, using Le Chatelier's Principle.
  - Silver chromate is insoluble. If colourless silver nitrate solution is added, silver chromate will precipitate. What effect will this have on the equilibrium position and the colour?
- 5 Answer the following questions, which refer to the reaction below in which ammonia is formed.  
 $\text{N}_2(\text{g}) + 3\text{H}_2(\text{g}) \rightleftharpoons 2\text{NH}_3(\text{g}); \Delta H = -91 \text{ kJ mol}^{-1}$
- Is the reaction exothermic or endothermic?
  - Would energy be written as a reactant or as a product? Explain.
  - Joe thinks adding heat to a mixture at equilibrium will make the reaction proceed in the reverse direction. Lisa thinks  $\Delta H$  is small and it won't have an effect. Who is right? Explain.
- 6 Explain why lowering the pressure favours the reactants in the Haber Process.  
The equation for the formation of ammonia in the Haber Process is:  
 $\text{N}_2(\text{g}) + 3\text{H}_2(\text{g}) \rightleftharpoons 2\text{NH}_3(\text{g}) + 91 \text{ kJ}$
- 7 The salt, lead iodide is not very soluble.
- Write a balanced ionic equation for the dissolution of lead iodide,  $\text{PbI}_2(\text{s})$ .
  - The reaction is reversible. If this reaction has reached equilibrium, what will be the effect of adding more solid?

## 17.3 Equilibrium constant—a mathematical relationship

### Definition of $K_{\text{eq}}$

The graphs in section 17.2 Le Chatelier's Principle indicate there is a mathematical link between equilibrium concentrations. It can be stated as follows.

For a reversible reaction written as:



if the equilibrium concentrations of each reactant and product are measured, then the **equilibrium law expression** shown below will be constant.

$$K_{\text{eq}} = \frac{[\text{C}]^c \times [\text{D}]^d}{[\text{A}]^a \times [\text{B}]^b}$$

The **equilibrium constant**,  $K_{\text{eq}}$ , is the ratio of product concentrations to reactant concentrations, with each concentration raised to a power which equals the coefficient of the substance in the balanced equation. This does not mean each individual concentration is the same for every possible equilibrium position, but that at any position of equilibrium, the value of this expression is the same.

Concentrations of solids and pure liquids are not included in the equilibrium law expression, nor are solvents if their concentration is essentially constant.

The equilibrium law expression shows the relationship between the concentrations of the products and the reactants at equilibrium. The value of the equilibrium law expression is called the equilibrium constant.



## Worked example 17.3A

Write the equilibrium law expression for each of these reactions.

- a  $\text{N}_2(\text{g}) + 3\text{H}_2(\text{g}) \rightleftharpoons 2\text{NH}_3(\text{g})$
- b  $\text{NH}_3(\text{aq}) + \text{H}_2\text{O}(\text{l}) \rightleftharpoons \text{NH}_4^+(\text{aq}) + \text{OH}^-(\text{aq})$
- c  $\text{NiO}(\text{s}) + \text{CO}(\text{g}) \rightleftharpoons \text{Ni}(\text{s}) + \text{CO}_2(\text{g})$

The equilibrium law expressions are:

- a  $K_{\text{eq}} = \frac{[\text{NH}_3]^2}{[\text{N}_2] \times [\text{H}_2]^3}$
- b  $K_{\text{eq}} = \frac{[\text{NH}_4^+] \times [\text{OH}^-]}{[\text{NH}_3]}$
- c  $K_{\text{eq}} = \frac{[\text{CO}_2]}{[\text{CO}]}$

The only thing that alters the value of  $K_{\text{eq}}$  is temperature because of the effect temperature has on the equilibrium position. Every reaction has its own individual value for  $K_{\text{eq}}$  for each temperature. These values can be used in equilibrium calculations. If the coefficients of the equation are doubled, the expression will alter mathematically.

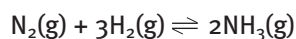
## Calculating $K_{\text{eq}}$

$K_{\text{eq}}$  can be calculated if the concentrations for one equilibrium position are known.



## Worked example 17.3B

The reaction below reaches equilibrium at  $400^\circ\text{C}$ .



The following concentrations are measured:  $[\text{N}_2] = 0.25 \text{ M}$ ,  $[\text{H}_2] = 0.75 \text{ M}$  and  $[\text{NH}_3] = 0.074 \text{ M}$ . Calculate  $K_{\text{eq}}$ .

The expression for  $K_{\text{eq}}$  is written and values substituted.

$$\begin{aligned}
 K_{\text{eq}} &= \frac{[\text{NH}_3]^2}{[\text{N}_2] \times [\text{H}_2]^3} \\
 &= \frac{0.074^2}{0.25 \times 0.75^3} \\
 &= 0.052
 \end{aligned}$$



$K$  may or may not have units, depending on the exact expression. However, for simplicity, we will omit units, and when calculating concentrations from  $K$ , will assume the usual units of concentration.

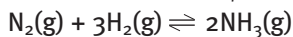
## Calculating an unknown concentration

The equilibrium constant, if known, can be used to calculate the unknown equilibrium concentration of a single reactant or product.



## ✓ Worked example 17.3C

The reaction has  $K_{\text{eq}} = 0.052$  at  $400^\circ\text{C}$ .



The concentrations of  $\text{N}_2$  and  $\text{H}_2$  at equilibrium are  $0.0011 \text{ M}$  each. Calculate the concentration of  $\text{NH}_3$  at equilibrium.

The expression for  $K_{\text{eq}}$  is written, and values are substituted. The equation is solved.

$$K_{\text{eq}} = \frac{[\text{NH}_3]^2}{[\text{N}_2] \times [\text{H}_2]^3}$$

$$0.052 = \frac{[\text{NH}_3]^2}{0.0011 \times (0.0011)^3}$$

$$0.052 \times 0.0011 \times (0.0011)^3 = [\text{NH}_3]^2$$

$$[\text{NH}_3]^2 = 7.61 \times 10^{-14}$$

$$[\text{NH}_3] = \sqrt{7.61 \times 10^{-14}}$$

$$[\text{NH}_3] = 2.7 \times 10^{-7} \text{ M}$$

## More complex calculations

The equilibrium concentrations can be calculated from a given starting mixture, for some reactions. This calculation is more complex. Even simple cases may involve solving a quadratic equation.

## ✓ Worked example 17.3D

$\text{PCl}_5$  decomposes into  $\text{PCl}_3$  and  $\text{Cl}_2$ , according to the equation



The value of  $K_{\text{eq}}$  is  $0.017$ . Initially,  $0.10 \text{ M}$  of  $\text{PCl}_5$  was present, and no product. Calculate the equilibrium concentration of each substance.

Note: It may seem as if the information is too limited. However, the equation will help us.

Let us begin by recognising that the mole ratio in the equation is  $1 : 1 : 1$ . Therefore, the decrease in the concentration of  $\text{PCl}_5$  will be equal to the increase in the concentrations of  $\text{PCl}_3$  and  $\text{Cl}_2$ . This quantity can be symbolised by  $x$ . The concentrations of  $\text{PCl}_3$  and  $\text{Cl}_2$  are both equal to  $x$ . The concentration of  $\text{PCl}_5$  has decreased by  $x$ , and can be written as  $0.10 - x$ .

Concentration information can be summarised in a table.

table 17.1

	$[\text{PCl}_5]$	$[\text{PCl}_3]$	$[\text{Cl}_2]$
initial	$0.10 \text{ M}$	0	0
change in concentration	$-x$	$x$	$x$
equilibrium concentration	$0.10 - x$	$x$	$x$

Expressions are developed for the equilibrium concentrations, using  $x$ .



$$K_{\text{eq}} = \frac{[\text{PCl}_3] \times [\text{Cl}_2]}{[\text{PCl}_5]}$$

$$0.017 = \frac{x^2}{(0.10 - x)}$$

$$x^2 = 0.0017 - 0.017x$$

$$0 = x^2 + 0.017x - 0.0017$$

The quadratic formula can be used to solve this equation.

$$x = 0.034 \text{ or } -0.051$$

The second value of  $x$  would produce negative values for concentrations. This is not possible. So this value can be ignored.

$$\text{So } x = 0.034$$

The equilibrium concentrations are found as follows.

$$\begin{aligned} [\text{PCl}_5] &= 0.10 - x \\ &= 0.10 - 0.034 \\ &= 0.066 \text{ M} \end{aligned}$$

$$\begin{aligned} [\text{PCl}_3] &= [\text{Cl}_2] = x \\ &= 0.034 \text{ M} \end{aligned}$$



For the equation:  
 $0 = ax^2 + bx + c$   
 the quadratic formula is  
 $x = \frac{-b \pm \sqrt{b^2 - 4ac}}{2a}$



The subscript,  $a$ , is used for the equilibrium constant of an acid. The subscript,  $b$ , is used for the equilibrium constant of a base.



$\text{H}^+$  is shown, rather than the hydronium ion,  $\text{H}_3\text{O}^+$ , for simplicity.

## Approximations to simplify calculations

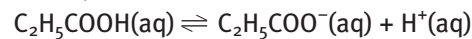
In cases where  $K_{\text{eq}}$  is very small, the calculations can be greatly simplified by approximations. Weak acids and bases typically have values of  $K_{\text{eq}}$  of the order of  $10^{-4}$  or less.



### Worked example 17.3E

The  $K_a$  for propanoic acid,  $\text{C}_2\text{H}_5\text{COOH}$ , is  $1.3 \times 10^{-5}$ . Calculate the concentration of hydrogen ions in a 0.50 M solution of the acid.

The equation for the ionisation of the acid is shown.



The concentrations of ions at equilibrium can be written in terms of  $x$ , as in table 17.2 below.

table 17.2

	$[\text{C}_2\text{H}_5\text{COOH}]$	$[\text{C}_2\text{H}_5\text{COO}^-]$	$[\text{H}^+]$
initial	0.50 M	0	0
change in concentration	$-x$	$x$	$x$
equilibrium concentration	$0.50 - x$	$x$	$x$

An expression for each equilibrium concentration can be written, using  $x$ .

The expression for  $K_a$  can be written as

$$K_a = \frac{[\text{C}_2\text{H}_5\text{COO}^-] \times [\text{H}^+]}{[\text{C}_2\text{H}_5\text{COOH}]}$$

$$1.3 \times 10^{-5} = \frac{x^2}{(0.50 - x)}$$



However, here a simplifying assumption can be made. As  $K_a$  for  $\text{CH}_3\text{COOH}$  is very small,  $x$  will be very tiny compared to the initial concentration of 0.050 M. Subtracting  $x$  from 0.05 M will have a negligible effect. The  $x$  can be left out of the denominator.

Thus:

$$1.3 \times 10^{-5} \times 0.50 = x^2$$

$$6.5 \times 10^{-6} = x^2$$

$$x = \sqrt{6.5 \times 10^{-6}}$$

$$x = 2.5 \times 10^{-3}$$

Check: The assumption was justified;  $x$  is much smaller than 0.50 M.

The concentration of hydrogen ions in this acid is  $2.5 \times 10^{-3}$  M.

The following tables list the  $K_a$  and  $K_b$  for some weak acids and bases, for your use in similar calculations.

**table 17.3** The  $K_a$  for some weak acids.

Acid	Formula	Equation	$K_a$
methanoic	HCOOH	$\text{HCOOH} \rightleftharpoons \text{HCOO}^- + \text{H}^+$	$1.6 \times 10^{-4}$
benzoic	$\text{C}_6\text{H}_5\text{COOH}$	$\text{C}_6\text{H}_5\text{COOH} \rightleftharpoons \text{C}_6\text{H}_5\text{COO}^- + \text{H}^+$	$6.3 \times 10^{-5}$
ethanoic	$\text{CH}_3\text{COOH}$	$\text{CH}_3\text{COOH} \rightleftharpoons \text{CH}_3\text{COO}^- + \text{H}^+$	$1.7 \times 10^{-5}$
hypochlorous	HClO	$\text{HClO} \rightleftharpoons \text{ClO}^- + \text{H}^+$	$3.7 \times 10^{-8}$
hydrocyanic	HCN	$\text{HCN} \rightleftharpoons \text{CN}^- + \text{H}^+$	$4.9 \times 10^{-10}$
nitrous	$\text{HNO}_2$	$\text{HNO}_2 \rightleftharpoons \text{NO}_2^- + \text{H}^+$	$4.7 \times 10^{-4}$

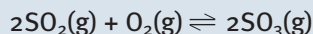
**table 17.4** The  $K_b$  for some weak bases.

Base	Formula	Equation	$K_b$
ammonia	$\text{NH}_3$	$\text{NH}_3 + \text{H}_2\text{O} \rightleftharpoons \text{NH}_4^+ + \text{OH}^-$	$1.8 \times 10^{-5}$
methylamine	$\text{CH}_3\text{NH}_2$	$\text{CH}_3\text{NH}_2 + \text{H}_2\text{O} \rightleftharpoons \text{CH}_3\text{NH}_3^+ + \text{OH}^-$	$4.38 \times 10^{-4}$
ethylamine	$\text{C}_2\text{H}_5\text{NH}_2$	$\text{C}_2\text{H}_5\text{NH}_2 + \text{H}_2\text{O} \rightleftharpoons \text{C}_2\text{H}_5\text{NH}_3^+ + \text{OH}^-$	$5.6 \times 10^{-4}$
aniline	$\text{C}_6\text{H}_5\text{NH}_2$	$\text{C}_6\text{H}_5\text{NH}_2 + \text{H}_2\text{O} \rightleftharpoons \text{C}_6\text{H}_5\text{NH}_3^+ + \text{OH}^-$	$3.8 \times 10^{-10}$
pyridine	$\text{C}_5\text{H}_5\text{N}$	$\text{C}_5\text{H}_5\text{N} + \text{H}_2\text{O} \rightleftharpoons \text{C}_5\text{H}_5\text{NH}^+ + \text{OH}^-$	$1.7 \times 10^{-9}$

## Questions

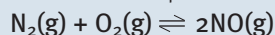
- 8** For the reactions below, write the expression to calculate the equilibrium constant.
- $2\text{HI}(\text{g}) \rightleftharpoons \text{H}_2(\text{g}) + \text{I}_2(\text{g})$
  - $\text{N}_2\text{O}_4(\text{g}) \rightleftharpoons 2\text{NO}_2(\text{g})$
  - $\text{Fe}^{3+}(\text{aq}) + \text{SCN}^-(\text{aq}) \rightleftharpoons \text{FeSCN}^{2+}(\text{aq})$
  - $\text{PbI}_2(\text{s}) \rightleftharpoons \text{Pb}^{2+}(\text{aq}) + 2\text{I}^-(\text{aq})$
- 9** Show that the following sets of equilibrium concentrations for the reaction below result in the same value for  $K_{\text{eq}}$  (within experimental error).
- $$\text{N}_2(\text{g}) + 3\text{H}_2(\text{g}) \rightleftharpoons 2\text{NH}_3(\text{g})$$
- Mixture A, with  $[\text{N}_2] = 0.55$  M,  $[\text{H}_2] = 0.65$  M and  $[\text{NH}_3] = 0.089$  M.
  - Mixture B, with  $[\text{N}_2] = 0.0025$  M,  $[\text{H}_2] = 0.0055$  M and  $[\text{NH}_3] = 4.6 \times 10^{-6}$  M.
- 10** Calculate the equilibrium constant for the reaction:
- $$2\text{SO}_2(\text{g}) + \text{O}_2(\text{g}) \rightleftharpoons 2\text{SO}_3(\text{g})$$
- The equilibrium concentrations are  $[\text{SO}_2] = 1.50$  M,  $[\text{O}_2] = 1.25$  M and  $[\text{SO}_3] = 3.50$  M.

- 11 The equilibrium constant for the following reaction is 4.3.



An equilibrium mixture contains the following concentrations:  $[\text{SO}_2] = 0.59 \text{ M}$  and  $[\text{O}_2] = 0.045 \text{ M}$ . Calculate the equilibrium concentration of  $\text{SO}_3$ .

- 12 At  $2200^\circ\text{C}$ ,  $K_{\text{eq}} = 0.050$  for the reaction below.



For each of the initial conditions, calculate the equilibrium concentration of each reactant and product.

- a  $[\text{N}_2] = [\text{O}_2] = 2.0 \text{ M}$ ,  $[\text{NO}] = 0.0 \text{ M}$   
(The mathematical calculations may be simplified by taking the square root of the expression obtained.)

- b  $[\text{N}_2] = 2.0 \text{ M}$ ,  $[\text{O}_2] = 1.0 \text{ M}$ ,  $[\text{NO}] = 0.0 \text{ M}$

- c  $[\text{N}_2] = 5.0 \text{ M}$ ,  $[\text{O}_2] = 1.0 \text{ M}$ ,  $[\text{NO}] = 0.0 \text{ M}$

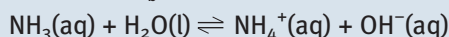
- d  $[\text{N}_2] = [\text{O}_2] = 0$ ,  $[\text{NO}] = 2.0 \text{ M}$

- e  $[\text{N}_2] = [\text{O}_2] = 2.0 \text{ M}$ ,  $[\text{NO}] = 1.0 \text{ M}$

- 13 Find the  $K_{\text{a}}$  for ethanoic (acetic) acid,  $\text{CH}_3\text{COOH}$ . Calculate the equilibrium concentration of  $\text{H}^+$  in a  $1.0 \text{ M}$  solution of the acid.

- 14 It is determined that 1.20% of a  $0.10 \text{ M}$  solution of a weak acid is ionised. Calculate the  $K_{\text{a}}$  for this acid.

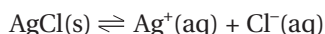
- 15 Ammonia,  $\text{NH}_3$ , is a weak base. Use table 17.4 to find the  $K_{\text{b}}$  for the reaction below.



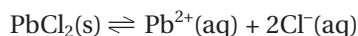
Calculate the equilibrium concentration of  $\text{OH}^-$  in a  $2.0 \text{ M}$  ammonia solution.

## 17.4 Solubility product

An important type of equilibrium constant is the **solubility product**, or  $K_{\text{sp}}$ , for the many ionic substances classed as insoluble or sparingly soluble. Even the most insoluble of these will reach a small, but measurable, equilibrium concentration. The equilibrium constant is known as the solubility product. It is found by calculating the product of the concentration terms each raised to a power equal to the coefficients of the substance in the dissociation equation. The equation for dissolving silver chloride,  $\text{AgCl}$ , is written as follows.



The expression for  $K_{\text{sp}}$  is written as  $[\text{Ag}^+] \times [\text{Cl}^-]$ . There is no denominator, as solids are not included in these calculations. The expression is the product of the concentrations of the ions. For lead chloride,  $\text{PbCl}_2$ , the equation is:



and

$$K_{\text{sp}} = [\text{Pb}^{2+}] \times [\text{Cl}^-]^2$$

### Calculating solubility

It may seem strange to talk about calculating the solubility of an insoluble substance. Remember that even if a substance is classed as insoluble, a very tiny amount can still dissolve. To carry out the calculations in this section, you will need the  $K_{\text{sp}}$  values for some salts. These are shown in table 17.5.



The solubility product is the equilibrium constant for the dissolution of an ionic compound.



The concentration of chloride ions is twice that of lead ions if the solution is made by dissolving lead chloride in pure water. The higher concentration is also squared, because of the rule used to find  $K$ .



**table 17.5** Values for  $K_{sp}$ , the solubility product, for some substances at 25°C.

Ionic solid	$K_{sp}$ (at 25°C)	Ionic solid	$K_{sp}$ (at 25°C)	Ionic solid	$K_{sp}$ (at 25°C)
<b>Fluorides</b>		<b>Sulfates</b>		<b>Carbonates</b>	
BaF <sub>2</sub>	$2.4 \times 10^{-5}$	CaSO <sub>4</sub>	$6.1 \times 10^{-5}$	CaCO <sub>3</sub>	$8.7 \times 10^{-9}$
MgF <sub>2</sub>	$6.4 \times 10^{-9}$	PbSO <sub>4</sub>	$1.6 \times 10^{-8}$	BaCO <sub>3</sub>	$1.6 \times 10^{-9}$
PbF <sub>2</sub>	$4 \times 10^{-8}$	BaSO <sub>4</sub>	$1.5 \times 10^{-9}$	CuCO <sub>3</sub>	$2.5 \times 10^{-10}$
<b>Chlorides</b>		<b>Hydroxides</b>		ZnCO <sub>3</sub>	$2 \times 10^{-10}$
PbCl <sub>2</sub>	$1.6 \times 10^{-8}$	Ba(OH) <sub>2</sub>	$5.0 \times 10^{-3}$	Ag <sub>2</sub> CO <sub>3</sub>	$8.1 \times 10^{-12}$
AgCl	$1.6 \times 10^{-10}$	Ca(OH) <sub>2</sub>	$1.3 \times 10^{-6}$	MgCO <sub>3</sub>	$1 \times 10^{-15}$
<b>Bromides</b>		AgOH	$2.0 \times 10^{-8}$	<b>Sulfides</b>	
PbBr <sub>2</sub>	$4.6 \times 10^{-6}$	Mg(OH) <sub>2</sub>	$8.9 \times 10^{-12}$	PbS	$7 \times 10^{-29}$
AgBr	$5.0 \times 10^{-13}$	Pb(OH) <sub>2</sub>	$1.2 \times 10^{-15}$	CuS	$8.5 \times 10^{-45}$
<b>Iodides</b>		Fe(OH) <sub>2</sub>	$1.8 \times 10^{-15}$	HgS	$1.6 \times 10^{-54}$
PbI <sub>2</sub>	$1.4 \times 10^{-8}$	Cu(OH) <sub>2</sub>	$1.6 \times 10^{-19}$	<b>Phosphates</b>	
AgI	$1.5 \times 10^{-16}$	Al(OH) <sub>3</sub>	$2 \times 10^{-32}$	Ca <sub>3</sub> (PO <sub>4</sub> ) <sub>2</sub>	$1.3 \times 10^{-32}$
		Fe(OH) <sub>3</sub>	$4 \times 10^{-38}$		

The following examples show how to calculate the solubility of an ionic substance in pure water. An equation for the dissolution and dissociation of the ions in solution is written. The symbol,  $s$ , will be used to represent the solubility in mol L<sup>-1</sup>.

### Worked example 17.4A

Calculate the solubility of lead sulfate, in mol L<sup>-1</sup>.

Step 1: The equation for dissolving is written, and the  $K_{sp}$  is found.

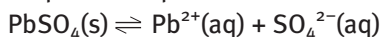


Table 17.5 shows the  $K_{sp} = 1.6 \times 10^{-8}$ .

Step 2: Concentrations are written in terms of  $s$ .

If  $s$  mol L<sup>-1</sup> dissolve, then at equilibrium  $[\text{Pb}^{2+}] = [\text{SO}_4^{2-}] = s$

Step 3: The expression for  $K_{sp}$  is written, and values and symbols substituted. The equation is solved for  $s$ .

$$K_{sp} = [\text{Pb}^{2+}] \times [\text{SO}_4^{2-}]$$

$$1.6 \times 10^{-8} = s \times s$$

$$s^2 = 1.6 \times 10^{-8}$$

$$s = \sqrt{1.6 \times 10^{-8}}$$

$$s = 1.3 \times 10^{-4} \text{ mol L}^{-1}$$

At equilibrium,  $[\text{Pb}^{2+}] = [\text{SO}_4^{2-}] = 1.3 \times 10^{-4} \text{ mol L}^{-1}$ .



## Worked example 17.4B

Calculate the solubility and the equilibrium concentrations of the ions for a solution of  $\text{MgF}_2$ .

Step 1: The equation for dissolving is written and the  $K_{\text{sp}}$  is found.

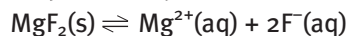


Table 17.5 shows the  $K_{\text{sp}} = 6.4 \times 10^{-9}$ .

Step 2: Concentrations are written in terms of  $s$ .

At equilibrium,  $[\text{Mg}^{2+}] = s$  and  $[\text{F}^{-}] = 2s$ . Dissolving this substance releases twice as many fluoride ions as magnesium ions.

Step 3: The expression for  $K_{\text{sp}}$  is written, and values and symbols substituted. The equation is solved for  $s$ .

$$K_{\text{sp}} = [\text{Mg}^{2+}] \times [\text{F}^{-}]^2$$
$$6.4 \times 10^{-9} = s \times (2s)^2$$
$$4s^3 = 6.4 \times 10^{-9}$$

$$s^3 = \frac{6.4 \times 10^{-9}}{4}$$

$$s^3 = 1.6 \times 10^{-9}$$

$$s = \sqrt[3]{1.6 \times 10^{-9}}$$

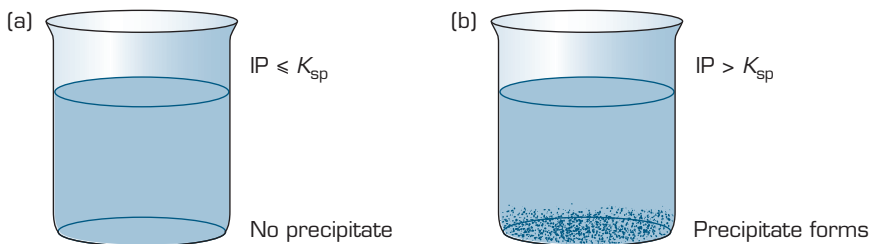
$$s = 1.2 \times 10^{-3} \text{ mol L}^{-1}$$

At equilibrium,  $[\text{Mg}^{2+}] = 1.2 \times 10^{-3} \text{ mol L}^{-1}$  and  $[\text{F}^{-}] = 2.4 \times 10^{-3} \text{ mol L}^{-1}$ .

## Will a precipitate form?

If solutions of ionic compounds are mixed and the mixture contains ions that will form an insoluble salt, then a precipitate may be expected to form. Knowledge of  $K_{\text{sp}}$  values leads you to realise that this may not always be the case. If the concentrations of the ions are equal to or below a certain threshold, then no precipitate will form.

Just because ions that form an insoluble salt are present in the mixture, does not mean you can assume there will be a precipitate. It is necessary to calculate the ionic product (IP) and compare it with the  $K_{\text{sp}}$ . Figure 17.10 shows how this idea is applied.



**figure 17.10** (a) If the ionic product, IP, is less than or equal to the solubility product,  $K_{\text{sp}}$ , then no precipitate will form; the ions are below their equilibrium concentrations. (b) If the ionic product, IP, is greater than the solubility product,  $K_{\text{sp}}$ , then a precipitate will form. The ions are above their equilibrium concentrations and react to make solid until  $\text{IP} = K_{\text{sp}}$ .



The mathematical expression for the ionic product is the same as the  $K_{\text{sp}}$  expression. It has a different name, as the concentrations used are not necessarily equilibrium conditions.





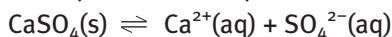
## Worked example 17.4C

5 mL of 0.002 M  $\text{Ca}(\text{NO}_3)_2$  solution is mixed with 5 mL of 0.01 M  $\text{Na}_2\text{SO}_4$  solution. Will a precipitate form?

Step 1: Determine the possible precipitate, and write an equation for the reaction.

The possible new compounds that could form are  $\text{NaNO}_3$ , which is soluble, and  $\text{CaSO}_4$ , which is insoluble. From table 17.5,  $\text{CaSO}_4$  has a  $K_{\text{sp}}$  of  $6.1 \times 10^{-5}$ .

The equation for the possible reaction, with the solid written first, is



Step 2: Determine the concentration of each ion in this reaction.

The mixed solutions dilute each other, so concentrations need to be recalculated after mixing, as in table 17.6. The shaded cells show two possible methods for calculating the concentration of ions after mixing. Because the ions are mixed in the ratio 1 : 1, the concentration after mixing is  $\frac{1}{2}$  that of the original concentration. Alternatively, you may use the rule for dilutions,  $c_1V_1 = c_2V_2$ .

table 17.6 The concentrations of various ions, before and after mixing.

	$[\text{Ca}^{2+}]$	$[\text{SO}_4^{2-}]$
before mixing	0.002 M	0.01 M
after mixing, calculation using proportions	$c = \frac{1}{2} \times 0.002 \text{ M}$	$c = \frac{1}{2} \times 0.01 \text{ M}$
(alternative calculation)	$c_1V_1 = c_2V_2$	$c_1V_1 = c_2V_2$
after mixing, calculation using $c_1V_1 = c_2V_2$	$0.002 \times 5 = c_2 \times 10$	$0.01 \times 5 = c_2 \times 10$
after mixing, before precipitation (calculated value)	0.001 M	0.005 M

Step 3: Write the expression for IP, and substitute the concentrations after mixing.

$$\begin{aligned} \text{IP} &= [\text{Ca}^{2+}] \times [\text{SO}_4^{2-}] \\ &= 0.001 \times 0.005 \\ &= 5 \times 10^{-6} \end{aligned}$$

Step 4: Compare the IP with the  $K_{\text{sp}}$  and determine if a precipitate forms.

$$5 \times 10^{-6} < 6.1 \times 10^{-5}$$

So,  $\text{IP} < K_{\text{sp}}$  and a precipitate will not form. (If  $\text{IP} > K_{\text{sp}}$  a precipitate will form.)

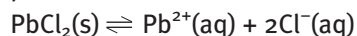


## Worked example 17.4D

1 mL of 0.1 M  $\text{CaCl}_2$  solution is added to 4 mL of 0.05 M  $\text{Pb}(\text{NO}_3)_2$  solution. Will a precipitate form?

Step 1: Determine the possible precipitate, and write an equation for the reaction.

Possible new compounds which could form are  $\text{Ca}(\text{NO}_3)_2$ , which is soluble, and  $\text{PbCl}_2$ , which is insoluble with  $K_{\text{sp}}$  of  $1.6 \times 10^{-8}$ . The equation for the possible reaction, with the solid written first, is



Step 2: Determine the concentration of each ion in this reaction.

The concentrations before and after mixing are calculated in table 17.7.

The concentration of chloride ions in calcium chloride is double the stated concentration of the solution. Why?

table 17.7

	$[\text{Pb}^{2+}]$	$[\text{Cl}^{-}]$
before mixing	0.05 M	0.2 M
after mixing, calculation using proportions	$c = \frac{4 \times 0.05 \text{ M}}{5}$	$c = \frac{1 \times 0.2 \text{ M}}{5}$
(alternative calculation)	$c_1V_1 = c_2V_2$	$c_1V_1 = c_2V_2$
after mixing, calculation using $c_1V_1 = c_2V_2$	$0.05 \times 4 = c_2 \times 5$	$0.2 \times 1 = c_2 \times 5$
after mixing, before precipitation	0.04 M	0.04 M

The concentrations of ions before and after mixing are calculated. The solutions are mixed in the ratio 1 : 4. This can be used to calculate the concentration after mixing, using either method shown.

Step 3: Write the expression for IP, and substitute the concentrations after mixing.

$$\begin{aligned} \text{IP} &= [\text{Pb}^{2+}] \times [\text{Cl}^{-}]^2 \\ &= 0.04 \times 0.04^2 \\ &= 6.4 \times 10^{-5} \end{aligned}$$

Step 4: Compare the IP with the  $K_{\text{sp}}$  and determine if a precipitate forms.

$\text{IP} > K_{\text{sp}}$ , therefore a precipitate will form.

## The common ion effect

Solutions in nature usually consist of a mixture of solutes in the solvent. Sea water and groundwater both contain many different ionic solids dissolved in water. Ions from one salt may influence the solubility of another salt, if a particular ion is common to both salts. The **common ion effect** is the lowering of the solubility of a substance by the presence of a common ion. For example, silver chloride will be much less soluble in sea water than in distilled water because sea water already contains chloride ions from other salts.



The **common ion effect** is the lowering of the solubility of a salt, in a solution already containing an ion of that salt.





## Worked example 17.4

Calculate the solubility of silver chloride in a 0.1 M solution of sodium chloride.

Step 1: Write the equation for dissolving AgCl, and look up its  $K_{sp}$ .

The  $K_{sp}$  of AgCl is  $1.6 \times 10^{-10}$ . The equation for the dissolving is  $\text{AgCl(s)} \rightleftharpoons \text{Ag}^+(\text{aq}) + \text{Cl}^-(\text{aq})$

Step 2: Using  $x$  to represent the amount of AgCl that dissolves per litre, write expressions for the equilibrium concentrations of each ion.

Table 17.8 shows the expressions for the equilibrium concentrations of each ion.

table 17.8 Concentrations for the calculation.

	[Ag <sup>+</sup> ]	[Cl <sup>-</sup> ]
concentration before dissolving	0	0.1 M
change in concentration	$x$	$x$
equilibrium concentration	$x$	$0.1 + x$

Step 3: Write the  $K_{sp}$  expression, substitute and solve.

$$K_{sp} = [\text{Ag}^+] \times [\text{Cl}^-]$$

$$1.6 \times 10^{-10} = x \times (0.1 + x)$$

A simplifying assumption can be made. As  $K_{sp}$  is very small,  $x$  will be much smaller than the initial concentration of  $\text{Cl}^-$  ions, 0.1 M. So  $(0.1 + x) \approx 0.1$ , and 0.1 can be used in place of  $(0.1 + x)$ .

$$1.6 \times 10^{-10} \approx x \times 0.1$$

$$x = \frac{1.6 \times 10^{-10}}{0.1}$$

$$x = 1.6 \times 10^{-9}$$

The solubility of AgCl in 0.1 M NaCl is  $1.6 \times 10^{-9} \text{ mol L}^{-1}$ .

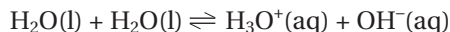
## Questions

- Calculate the solubility of barium sulfate. Note that although barium salts are poison to humans, barium sulfate is swallowed in certain medical procedures. Why is this possible?
- Calculate the concentration of both types of ions in a saturated solution of calcium hydroxide.
- The Burdekin Dam is the largest dam in Queensland and can hold a volume of 1 860 000 ML.
  - What mass of the very insoluble salt, mercury(II) sulfide,  $\text{HgS}$ , could dissolve in the water of the Burdekin Dam?
  - How many  $\text{Hg}^{2+}$  ions does this represent?
- 5 mL of  $2 \times 10^{-8} \text{ M AgNO}_3$  solution is mixed with 5 mL of 0.02 M NaCl solution. Will a precipitate form?
- 10 mL of 0.0006 M  $\text{Ca(NO}_3)_2$  solution is mixed with 20 mL of 0.0003 M  $\text{Na}_2\text{CO}_3$  solution. Will a precipitate form?
- Calculate the solubility of zinc carbonate,  $\text{ZnCO}_3$ , in a 0.05 M solution of zinc nitrate,  $\text{Zn(NO}_3)_2$ . State the final concentrations of each of the ions present.
- Calculate the solubility of calcium hydroxide in a solution that is 0.2 M in calcium ions.



## 17.5 $K_w$

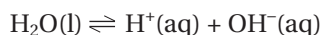
A reversible reaction that is extremely important in many natural and living systems is the self-ionisation of water. In this reaction, a small fraction of water molecules donate a hydrogen ion or proton to other water molecules. The products are a hydronium ion,  $\text{H}_3\text{O}^+$ , and a hydroxide ion,  $\text{OH}^-$ . The equation for this reaction is:



The equilibrium constant for this reaction is:

$$K_w = [\text{H}_3\text{O}^+] \times [\text{OH}^-]$$

This equation and the  $K_w$  are often written more simply as:



and

$K_w = [\text{H}^+] \times [\text{OH}^-]$ , where the symbol  $\text{H}^+$  is used to signify the hydronium ion.

The value of  $K_w$  at  $25^\circ\text{C}$  is  $1 \times 10^{-14}$ . This reaction rapidly reaches equilibrium and is established not only in pure water but also in any aqueous solutions.

The concentration of hydrogen and hydroxide ions in pure water can be calculated as follows. In pure water,  $[\text{H}^+] = [\text{OH}^-] = x$ .

$$K_w = [\text{H}^+] \times [\text{OH}^-]$$

$$1 \times 10^{-14} = x^2$$

$$x = \sqrt{1 \times 10^{-14}}$$

$$x = [\text{H}^+] = [\text{OH}^-] = 1 \times 10^{-7} \text{ mol L}^{-1}$$

The addition of a substance with a higher concentration of  $\text{H}^+$  ions or  $\text{OH}^-$  will immediately effect the position of this equilibrium. Solutions in which  $[\text{H}^+] > 1 \times 10^{-7} \text{ M}$  are known as acids, while solutions in which  $[\text{OH}^-] > 1 \times 10^{-7} \text{ M}$  are known as bases, or alkalis.



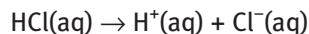
An alkali is a soluble base.



### Worked example 17.5A

Hydrochloric acid,  $\text{HCl}$ , is a strong acid. It fully ionises in water. Calculate the concentrations of hydrogen ions and hydroxide ions in a  $0.5 \text{ M}$  solution of  $\text{HCl}$ .

The equation for the ionisation of  $\text{HCl}$  is



Because  $\text{HCl}$  fully ionises,  $[\text{HCl}]$  is approximately zero, and

$$[\text{H}^+] = [\text{Cl}^-] = 0.5 \text{ M}.$$

To calculate  $[\text{OH}^-]$

$$K_w = [\text{H}^+] \times [\text{OH}^-]$$

$$1 \times 10^{-14} = 0.5 \times [\text{OH}^-]$$

$$[\text{OH}^-] = \frac{1 \times 10^{-14}}{0.5}$$

$$[\text{OH}^-] = 2 \times 10^{-14} \text{ M}$$

The concentrations of  $\text{H}^+$  and  $\text{OH}^-$  are both dramatically affected by changes in each other.




$$\text{pH} = -\log[\text{H}_3\text{O}^+]$$

## pH

The concentration of hydronium (or hydrogen) ions in a solution is an important property of many systems. As seen in Worked example 17.5A, it can vary from more than 1 M to less than  $1 \times 10^{-14}$  M. To avoid quoting extremely small concentrations, the pH scale is frequently used. The pH of a solution is defined as the negative of the log to base 10 of the hydronium ion concentration. This is shown mathematically as

$$\text{pH} = -\log[\text{H}_3\text{O}^+]$$

or, more simply as

$$\text{pH} = -\log[\text{H}^+]$$

If the pH is known,  $[\text{H}^+]$  can be found.

$$[\text{H}^+] = 10^{-\text{pH}}$$



pH does not have units.



### Worked example 17.5B

Calculate the pH of a 0.50 M solution of HCl.

HCl is a strong acid, so  $[\text{H}^+] = 0.50$  M

$$\begin{aligned}\text{pH} &= -\log[\text{H}^+] \\ &= -\log 0.50 \\ &= 0.30\end{aligned}$$



### Worked example 17.5C

Oranges have a pH of about 3.6. Calculate the concentration of hydrogen ions in orange juice.

$$\begin{aligned}[\text{H}^+] &= 10^{-\text{pH}} \\ [\text{H}^+] &= 10^{-3.6} \\ [\text{H}^+] &= 2.5 \times 10^{-4} \text{ M}\end{aligned}$$



### Worksheet 2

Equilibrium constant



### Worksheet 3

Reversible reactions II

## Questions

- In Worked example 17.3E, the concentration of hydrogen ions in a 0.5 M solution of propanoic acid was calculated. Calculate the  $[\text{OH}^-]$ . Compare the concentrations of hydrogen and hydroxide ions with those in the 0.5 M solution of HCl.
- Using the information in table 17.3, calculate  $[\text{H}^+]$  and  $[\text{OH}^-]$  in a 2.0 M solution of ethanoic (acetic) acid,  $\text{CH}_3\text{COOH}$ .
- A particular household cleaning solution contains ammonia, with a concentration of 0.05 M. Using the  $K_b$  of ammonia from table 17.4, calculate the concentration of hydroxide ions in this solution. Hence, calculate the concentration of hydrogen ions.
- Calculate the pH of a 0.20 M solution of the strong acid, nitric acid.
- Calculate the pH of a 2.0 M solution of the weak acid, hydrocyanic acid.
- Rainwater has a pH of about 5.8. Calculate the concentration of hydrogen ions in rainwater.
- Sea water has a pH of about 9.2. Calculate  $[\text{H}^+]$  and  $[\text{OH}^-]$  in sea water.
- Compare the pH values of a 2.0 M solution of hydrochloric acid, a 2.0 M solution of methanoic acid and a 2.0 M solution of hypochlorous acid.

## Summary ▶▶▶▶

- ▶ When an ionic solid is dissolved in water the ions **dissociate** and become **hydrated**. Eventually a point is reached where no more solid will dissolve. The solution is called a **saturated solution**. The process of dissolving has not stopped. Dissolving and recrystallising are occurring, but at the same rate.
- ▶ Many chemical reactions also reach a similar state. These reactions are examples of **reversible reactions**. This state is called **dynamic equilibrium**.
- ▶ This is in contrast to a **steady state system**. In such a system, concentrations remain relatively constant, but this is because reactants are continually supplied and products removed. The rates of the forward and reverse reactions are not equal in a steady state system.
- ▶ The **position of equilibrium** describes whether reactants or products are favoured at equilibrium. For a reaction in which a high proportion of reactants remain at equilibrium, it may be said that the position of equilibrium lies to the left.
- ▶ To understand why some reactions are reversible, we need to consider the **driving forces** of a reaction. Reactions tend to proceed to lower enthalpy and higher entropy. In some cases, these driving forces oppose each other, and the reaction will proceed to varying degrees. These reactions are reversible.
- ▶ **Le Chatelier's Principle** states: If a change is applied to a system at equilibrium, the system partially (or fully) counteracts the change, in order to return to equilibrium. This can be applied to changes in concentration, temperature and, for gases, pressure.
- ▶ The **equilibrium law expression** is a mathematical ratio of the concentrations of products and reactants, each raised to a power equal to their coefficient in the reaction equation. If the equilibrium concentrations of each reactant and product are measured, then the equilibrium law expression will be constant for a particular temperature.
- ▶ The **equilibrium constant**,  $K_{eq}$ , is the numerical value of the equilibrium law expression.
- ▶ The equilibrium constants for weak acids and bases are given the symbols  $K_a$  and  $K_b$ . The equilibrium constant for dissolving an ionic compound is called the **solubility product**, or  $K_{sp}$ . This can be used to determine if a precipitate will form when given ions in solution are mixed. It can also be used for calculations involving the **common ion effect**, when a salt is being dissolved in a solution that contains other ions.
- ▶  $K_w$  is the symbol for the equilibrium constant for the self-ionisation of water. The value of  $K_w$  at  $25^\circ\text{C}$  is  $1 \times 10^{-14}$ . The wide range of concentrations of hydrogen ions that occur, make it convenient to use **pH**.

## Key terms ▶▶

common ion effect

dissociate

driving forces

dynamic equilibrium

equilibrium constant,  $K_{eq}$

equilibrium law expression

hydrated

$K_a$

$K_b$

$K_w$

Le Chatelier's Principle

pH

position of equilibrium

reversible reaction

saturated solution

solubility product,  $K_{sp}$

steady state system

## Chapter Review

### 17.1 Reversible reactions

- 31 A mixture of hydrogen gas and purple iodine vapour is sealed in a glass tube where it undergoes a reaction to form colourless hydrogen iodide gas. Which of the following could be used as a sign that equilibrium has been achieved?
- A constant pressure
  - B constant colour
  - C constant mass
  - D constant volume
- 32 a What is meant by the term dynamic equilibrium?  
b Describe what is occurring at atomic level when a reaction has reached equilibrium.

### 17.2 Le Chatelier's Principle

33

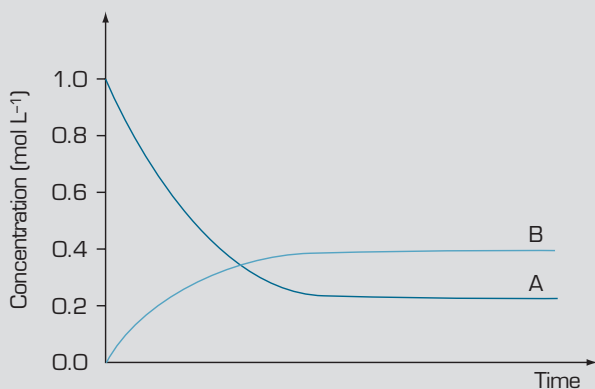


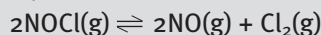
figure 17.11

The concentration–time diagram in figure 17.11 could represent the concentrations of A and B in the equation:

- A  $A \rightarrow B + C$
  - B  $B + C \rightarrow A$
  - C  $2A \rightarrow B + C$
  - D  $A + C \rightarrow 2B$
- 34 The formation of sulfur trioxide is described by the equation:
- $$2\text{SO}_2(\text{g}) + \text{O}_2(\text{g}) \rightleftharpoons 2\text{SO}_3(\text{g}); \Delta H \text{ negative}$$
- If the temperature is increased:
- A the value of the equilibrium constant will decrease.
  - B the value of the equilibrium constant will increase.
  - C the value of the equilibrium constant will stay the same but equilibrium will be reached more quickly.

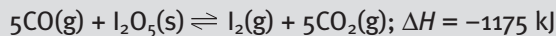
D the value of the equilibrium constant will stay the same but equilibrium will be reached more slowly.

- 35 A sample of NOCl is allowed to come to equilibrium according to the following equation:



The volume of the mixture is halved and allowed to come to a new equilibrium, the temperature remains constant. At the new equilibrium the chlorine has:

- A decreased in amount and decreased in concentration.
  - B increased in amount and decreased in concentration.
  - C decreased in amount and increased in concentration.
  - D increased in amount and increased in concentration.
- 36 Carbon dioxide gas dissolves to a small extent in water, forming carbonic acid in an exothermic reaction:
- $$\text{CO}_2(\text{g}) + \text{H}_2\text{O}(\text{l}) \rightleftharpoons \text{H}_2\text{CO}_3(\text{aq}); \Delta H \text{ negative}$$
- $$\text{H}_2\text{CO}_3(\text{aq}) + \text{H}_2\text{O}(\text{l}) \rightleftharpoons \text{HCO}_3^-(\text{aq}) + \text{H}_3\text{O}^+(\text{aq})$$
- This is the reaction involved in forming fizzy drinks.
- Which of the following strategies would not be effective at increasing the amount of dissolved carbon dioxide?
- A Decreasing the pH of the solution
  - B Decreasing the temperature of the solution
  - C Increasing the concentration of carbon dioxide in the gas
  - D Increasing the pressure of the carbon dioxide gas
- 37 Carbon monoxide and iodine pentoxide react to form iodine and carbon dioxide in the equilibrium reaction:



Change	Quantity	Effect
increase T	$K_{\text{eq}}$	
decrease T	amount $\text{I}_2\text{O}_5(\text{s})$	
add $\text{I}_2(\text{g})$	$K_{\text{eq}}$	
add $\text{CO}_2(\text{g})$	amount $\text{I}_2(\text{g})$	
double volume	concentration $\text{CO}_2$	
remove CO	amount $\text{CO}_2$	
add catalyst	$\text{I}_2(\text{g})$	
add inert gas Ar	$K_{\text{eq}}$	

Use your knowledge of Le Chatelier's Principle to predict the effect of the change (column 1) on the designated quantity (column 2). Complete the effect on the equilibrium (column 3) by using the terms decrease, increase, no change. Assume that the change listed is the only one taking place, e.g. if  $I_2$  is added, the volume and the temperature are kept constant.

- 38 The reaction between hydrogen and iodine in the gaseous phase to produce hydrogen iodide is described by the equation:

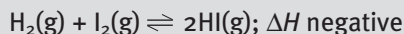


Figure 17.12 shows the change in concentration of gaseous hydrogen, iodine and hydrogen iodide as the equilibrium is reached and disturbed.

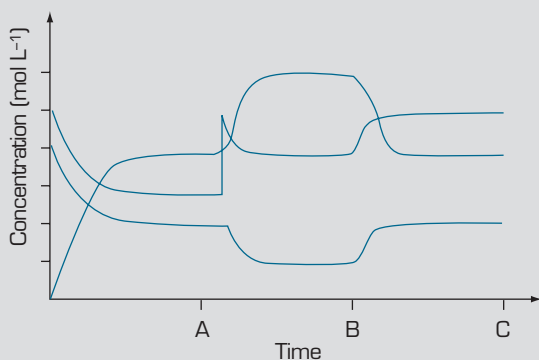


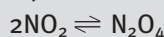
figure 17.12

- a At point A, a sudden change occurs to the system. What has occurred?
- b At point B, another change has occurred. What has happened?
- c Copy the graph and mark with an 'X' on the time axis, a point when the system is at equilibrium.
- d Extend the graph past point C to show what would happen to the concentration of the gases if the volume of the reaction vessel was doubled, until equilibrium is obtained. Assume the temperature remains constant.
- 39 The solubility of carbon dioxide in natural systems is affected by a number of competing equilibria:
- Equation 1:  $CO_2(g) + H_2O(l) \rightleftharpoons H_2CO_3(aq)$
- Equation 2:  $H_2CO_3(aq) + Ca(OH)_2(aq) \rightleftharpoons CaCO_3(s) + 2H_2O(l)$
- Equation 3:  $CaCO_3(s) + CO_2(g) + H_2O(l) \rightleftharpoons Ca^{2+}(aq) + 2HCO_3^-(aq)$
- a The concentration of carbon dioxide in the air has increased over the last 200 years. What is the source of this increased carbon dioxide?

- b Use the equation(s) above and your knowledge of Le Chatelier's Principle to explain how the oceans can act as a carbon dioxide sink
- c Use the equation(s) above to explain the dissolution of limestone in carbon dioxide rich waters in caves.

## 17.3 Equilibrium constant—a mathematical relationship

- 40 Two samples of pure  $NO_2$  are placed into separate sealed 1 L containers and allowed to reach equilibrium:

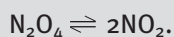


Mixture A consists initially of 2 mol pure  $NO_2$ . Mixture B consists initially of 1 mol  $NO_2$ . Both are at the same temperature. Consider the following values in each mixture at equilibrium:

- I Ratio  $[NO_2]/[N_2O_4]$  at equilibrium.
- II Ratio  $[NO_2]^2/[N_2O_4]$  at equilibrium.
- III Ratio  $[N_2O_4]/[NO_2]^2$  at equilibrium.
- IV Time taken for equilibrium to be established.

Which will be different in the two mixtures?

- A I only
- B I and II
- C II and III
- D I and IV
- 41 The reaction between nitrogen monoxide and ozone is:
- $$NO(g) + O_3(g) \rightleftharpoons NO_2(g) + O_2(g);$$
- $$K = 6 \times 10^{34} \text{ at } 25^\circ C$$
- An equal amount of NO and  $O_3$  are used. Which of the following statements cannot be inferred from the magnitude of the equilibrium constant?
- A  $[NO_2][O_2] \gg [NO][O_3]$
- B The equilibrium of the reaction lies well to the right.
- C The reaction has a low activation energy.
- D Very little ozone will remain at equilibrium.
- 42 a State Le Chatelier's Principle.
- b State the equilibrium law expression for the reaction:
- $$aA + bB \rightleftharpoons cC + dD$$
- c What is meant by the equilibrium constant?
- 43 Dinitrogen tetroxide,  $N_2O_4$ , and nitrogen dioxide,  $NO_2$ , coexist according to the equilibrium reaction:



A concentration-time graph for the system coming to equilibrium is shown in figure 17.13.

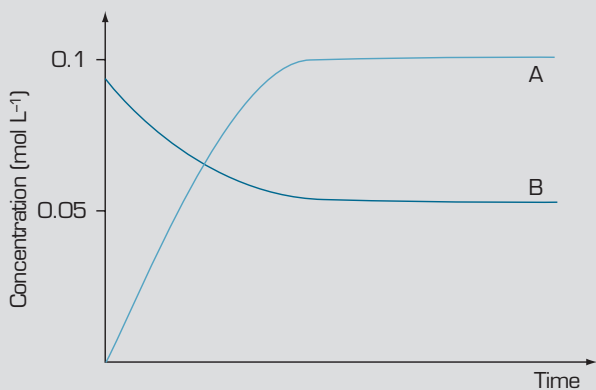


figure 17.13

- a Identify A and B.  
 b Write an expression for the equilibrium constant of the decomposition of  $\text{N}_2\text{O}_4$ .  
 c Copy the graph and indicate the effect on A if a catalyst were added to the mixture.  
 d Calculate  $K$  for the reaction at equilibrium according to this concentration graph.
- 44 The equilibrium for the reaction of nitrogen dioxide to form nitrogen tetroxide is shown:  
 $2\text{NO}_2(\text{g}) \rightleftharpoons \text{N}_2\text{O}_4(\text{g}); K_{\text{eq}} = 170$  at 298 K  
 A mixture of the gases was found to contain 0.015 M  $\text{NO}_2$  and 0.025 M  $\text{N}_2\text{O}_4$ .  
 a Calculate the reaction quotient,  $Q$ , for the mixture shown. The reaction quotient has the same mathematical expression as  $K_{\text{eq}}$  for that reaction.  
 b Is the mixture at equilibrium? If no, should more  $\text{N}_2\text{O}_4$  or  $\text{NO}_2$  be formed for the mixture to reach equilibrium? Consider which way the reaction should proceed to make the value of  $K_{\text{eq}}$  equal to the value of  $Q$ .
- 45 In the industrial production of sulfuric acid, sulfur trioxide is formed from sulfur dioxide and oxygen:  
 $2\text{SO}_2(\text{g}) + \text{O}_2(\text{g}) \rightleftharpoons 2\text{SO}_3(\text{g});$   
 $K = 1.28 \times 10^4$  at 852 K  
 At equilibrium  $[\text{SO}_3] = 1.01 \times 10^{-2}$  M and  $[\text{O}_2] = 6.11 \times 10^{-4}$  M  
 a Write an expression for the equilibrium constant.  
 b Determine the concentration of sulfur dioxide in the equilibrium mixture.
- 46 If hydrogen iodide is heated it will decompose to form iodine and hydrogen. In a sealed container at 425°C the following equilibrium was obtained:  
 $2\text{HI}(\text{g}) \rightleftharpoons \text{H}_2(\text{g}) + \text{I}_2(\text{g}); K = 55.64$  at 425°C

Initially 2.00 mol  $\text{H}_2$  and 2.00 mol  $\text{I}_2$  are placed in a 1 L flask with no hydrogen iodide present.

- a If  $x$  moles of hydrogen react to reach equilibrium, how many moles of iodine are consumed and how many moles of hydrogen iodide are formed?  
 b What is the equilibrium concentration of hydrogen, iodine and hydrogen iodide, in terms of  $x$ ?  
 c Substitute the values of the equilibrium concentrations of hydrogen, iodine and hydrogen iodide into the equilibrium expression and determine the number of moles of hydrogen iodide at equilibrium.
- 47 Dimethylamine,  $(\text{CH}_3)_2\text{NH}$ , is a weak base in water.  
 a Write an equation showing the reaction of the base with water.  
 b Write an expression for the equilibrium constant.
- 48 Propanoic acid (abbreviated to HPr) is a weak acid used to retard the growth of mould in foods. A 0.100 M solution was prepared. The acidity constant for the acid is:  

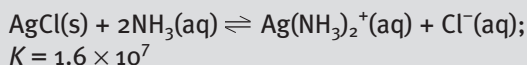
$$K_{\text{a}} = \frac{[\text{H}_3\text{O}^+][\text{Pr}^-]}{[\text{HPr}]} = 1.30 \times 10^{-5}$$
 M  
 a Assuming  $x$  moles of HPr dissociates, complete the following table.

	[HPr]	$[\text{H}_3\text{O}^+]$	$[\text{Pr}^-]$
initial concentration (M)	0.100	0	0
change in concentration (M)	$-x$		
equilibrium concentration (M)	$0.100 - x \approx 0.100$		

- b Determine  $[\text{H}_3\text{O}^+]$ .  
 c Determine the pH of the solution.  
 d Determine the percentage dissociation of HPr.
- 49 Antimony pentachloride decomposes in a gas phase reaction with  $K_{\text{eq}} = 2.51 \times 10^{-2}$  at 448°C.  
 $\text{SbCl}_5(\text{g}) \rightleftharpoons \text{SbCl}_3(\text{g}) + \text{Cl}_2(\text{g})$   
 a If 10.0 g of  $\text{SbCl}_5$  are placed in a 5.00 L container at 448°C and allowed to establish equilibrium, what will be the equilibrium concentrations of each gas?  
 b If 15.0 g of  $\text{SbCl}_5$  and 10.0 g of  $\text{SbCl}_3$  are placed in a 15.0 L container and allowed to establish equilibrium, what will be the equilibrium concentration of each gas?

## 17.4 Solubility product

- 50 The solubility of precipitates can be increased by using competing equilibria. Silver ions readily form a white precipitate of silver chloride but form a soluble complex with ammonia:



In order to increase the solubility of the silver chloride precipitate,  $\text{AgCl(s)}$ , it would be best to:

- A add sodium chloride solution to the mixture.
  - B add ammonia solution to the mixture.
  - C add silver ions in the form of silver nitrate solution to the mixture.
  - D add  $\text{H}^+$  ions to the mixture.
- 51 Compare the solubility of  $\text{CaSO}_4$  in pure water and in a 0.10 M solution of  $\text{K}_2\text{SO}_4$ .

## 17.5 $K_w$

- 52 Blood plasma has a hydrogen ion concentration of  $3.0 \times 10^{-7}$  M. The pH of the blood plasma is closest to:
- A 3.7
  - B 6.5
  - C 7
  - D 7.5
- 53 A solution of barium hydroxide,  $\text{Ba(OH)}_2$ , is found to have a pH of 12.60 at  $25^\circ\text{C}$ . Assuming that it fully ionises in water, what was the concentration of the barium hydroxide solution?
- A  $1.3 \times 10^{-13}$  M
  - B  $2.5 \times 10^{-13}$  M

C  $2.0 \times 10^{-2}$  M

D  $4.0 \times 10^{-2}$  M

- 54 A sample of lactic acid, a weak monobasic acid, was found to have a pH = 2.43 at  $25^\circ\text{C}$ . The concentration of  $\text{OH}^-$  of the acid was:

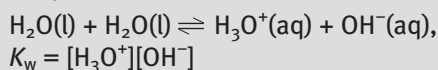
A  $3.71 \times 10^{-3}$  M.

B  $3.71 \times 10^{-11}$  M.

C  $2.70 \times 10^{-12}$  M.

D  $4.12 \times 10^{-15}$  M.

- 55 The self-ionisation of water is affected by temperature.



Temperature ( $^\circ\text{C}$ )	Ionisation constant for water, $K_w$
5	$1.85 \times 10^{-15}$
15	$4.51 \times 10^{-15}$
25	$1.00 \times 10^{-14}$
35	$2.09 \times 10^{-14}$

From the data it can be inferred that:

- A the pH of pure water at  $35^\circ\text{C}$  is less than 7.
  - B self-ionisation of water is an exothermic reaction.
  - C equilibrium for the reaction lies well to the left with mainly reactants present.
  - D  $[\text{OH}^-]$  of pure water at  $15^\circ\text{C}$  is less than  $[\text{H}_3\text{O}^+]$ .
- 56 Which of the following would have the highest pH: a saturated solution of  $\text{AgOH}$  or a saturated solution of  $\text{Mg(OH)}_2$ ? Use the  $K_{sp}$  values from table 17.5.



# Appendix A



Table of relative atomic masses

Name	Symbol	Atomic number	Relative atomic mass	Name	Symbol	Atomic number	Relative atomic mass
Actinium	Ac	89	—	Mercury	Hg	80	200.59
Aluminium	Al	13	26.9815	Molybdenum	Mo	42	95.94
Americium	Am	95	—	Neodymium	Nd	60	144.24
Antimony	Sb	51	121.75	Neon	Ne	10	20.179
Argon	Ar	18	39.948	Neptunium	Np	93	—
Arsenic	As	33	74.9216	Nickel	Ni	28	58.71
Astatine	At	85	—	Niobium	Nb	41	92.9064
Barium	Ba	56	137.34	Nitrogen	N	7	14.0067
Berkelium	Bk	97	—	Nobelium	No	102	—
Beryllium	Be	4	9.01218	Osmium	Os	76	190.2
Bismuth	Bi	83	208.9806	Oxygen	O	8	15.9994
Boron	B	5	10.81	Palladium	Pd	46	106.4
Bromine	Br	35	79.904	Phosphorus	P	15	30.9738
Cadmium	Cd	48	112.40	Platinum	Pt	78	195.90
Caesium	Cs	55	132.9055	Plutonium	Pu	94	—
Calcium	Ca	20	40.08	Polonium	Po	84	—
Californium	Cf	98	—	Potassium	K	19	39.102
Carbon	C	6	12.011	Praseodymium	Pr	59	140.9077
Cerium	Ce	58	140.12	Promethium	Pm	61	—
Chlorine	Cl	17	35.453	Protactinium	Pa	91	—
Chromium	Cr	24	51.996	Radium	Ra	88	—
Cobalt	Co	27	58.9332	Radon	Rn	86	—
Copper	Cu	29	63.54	Rhenium	Re	75	186.2
Curium	Cm	96	—	Rhodium	Rh	45	102.9055
Dysprosium	Dy	66	162.50	Rubidium	Rb	37	85.467
Einsteinium	Es	99	—	Ruthenium	Ru	44	101.07
Erbium	Er	68	167.26	Samarium	Sm	62	150.4
Europium	Eu	63	151.96	Scandium	Sc	21	44.9559
Fermium	Fm	100	—	Selenium	Se	34	78.96
Fluorine	F	9	18.9984	Silicon	Si	14	28.086
Francium	Fr	87	—	Silver	Ag	47	107.868
Gadolinium	Gd	64	157.25	Sodium	Na	11	22.9898
Gallium	Ga	31	69.72	Strontium	Sr	38	87.62
Germanium	Ge	32	72.59	Sulfur	S	16	32.06
Gold	Au	79	196.9665	Tantalum	Ta	73	180.947
Hafnium	Hf	72	178.49	Technetium	Tc	43	—
Helium	He	2	4.00260	Tellurium	Te	52	127.60
Holmium	Ho	67	164.9303	Terbium	Tb	65	158.9254
Hydrogen	H	1	1.0080	Thallium	Tl	81	204.37
Indium	In	49	114.82	Thorium	Th	90	232.0381
Iodine	I	53	126.9045	Thulium	Tm	69	168.9342
Iridium	Ir	77	192.22	Tin	Sn	50	118.69
Iron	Fe	26	55.847	Titanium	Ti	22	47.90
Krypton	Kr	36	83.80	Tungsten	W	74	183.85
Lanthanum	La	57	138.9055	Uranium	U	92	238.029
Lawrencium	Lr	103	—	Vanadium	V	23	50.941
Lead	Pb	82	207.2	Xenon	Xe	54	131.30
Lithium	Li	3	6.94	Ytterbium	Yb	70	173.04
Lutetium	Lu	71	174.97	Yttrium	Y	39	88.9059
Magnesium	Mg	12	24.305	Zinc	Zn	30	65.37
Manganese	Mn	25	54.9380	Zirconium	Zr	40	91.22
Mendelevium	Md	101	—				

\* Based on the atomic mass of  $^{12}\text{C} = 12$ .

The values for relative atomic masses given in the table apply to elements as they exist in nature, without artificial alteration of their isotopic composition, and, further, to natural mixtures that do not include isotopes of radiogenic origin.







## Chapter 1

- 4 a 48 b 48 c 64 5 a  $^{12}_6\text{C}$  b  $^{13}_6\text{C}$  c  $^{14}_6\text{C}$  d  $^{27}_{13}\text{Al}$   
 6 a  $^{16}_8\text{O}$  b  $^{34}_{16}\text{S}$  c  $^{130}_{56}\text{Ba}$  d  $^{138}_{56}\text{Ba}$   
 7 a 15,999 b 63,549 c 1.008 8 8.0%  
 9 a 2 b 3 c 1 d 4 e 2 f 8  
 10 a fluorine and bromine b silicon c oxygen and sulfur  
 d boron and aluminium  
 11 a 2,2 b 2,8,6 c 2,8,8 d 2,8,2 e 2,8  
 12 a helium, He b fluorine, F c aluminium, Al d nitrogen, N  
 e chlorine, Cl  
 13 a  $1s^2$  b  $1s^2 2s^2 2p^6 3s^2 3p^5$  c  $1s^2 2s^2 2p^6 3s^2 3p^6 4s^1$   
 d  $1s^2 2s^2 2p^6 3s^2 3p^6 3d^6 4s^2$  e  $1s^2 2s^2 2p^6 3s^2 3p^6 3d^{10} 4s^2 4p^6$   
 4d<sup>9</sup> 5s<sup>2</sup>  
 14 a beryllium b neon c silicon d chromium e strontium  
 15 a i Group 13 ii Group 17 iii Group 1 iv Group 18 v Group 14  
 b i 4 ii 2 iii 1 iv 3 v 1 c i silicon, Si, 2,8,4 ii beryllium, Be, 2,2  
 iii argon, Ar, 2,8,8  
 16 a 2 b 7 c 1 d 6 e 4  
 17 B 18 A 19 500 m 20 B 21 C  
 22 a D and F, G and H b B, C, D and I c C d A e 7  
 24 92; 235 26 No 28 a 106.4  
 30  $A_r(\text{Li}) = 6.95$ ;  $A_r(\text{Mg}) = 24.31$ ;  $A_r(\text{Cu}) = 63.57$ ;  $A_r(\text{Si}) = 28.09$ ;  
 $A_r(\text{Ga}) = 69.74$   
 31 a  $A_r(\text{Ar}) = 39.96$ ;  $A_r(\text{K}) = 39.11$   
 32 73.5% and 26.5%  
 33 a 51.5% b 61.5% c 20.2% d 76.5% 34 8  
 35 a 2,8,7; 2,8,3; 2,8,8,1 b Group 17, Period 3; Group 13,  
 Period 3; Group 1, Period 4  
 36 a  $1s^2$  b  $1s^2 2s^2 2p^2$  c  $1s^2 2s^2 2p^5$  d  $1s^2 2s^2 2p^6 3s^2 3p^1$   
 e  $1s^2 2s^2 2p^6 3s^2 3p^6$  f  $1s^2 2s^2 2p^6 3s^2 3p^6 3d^8 4s^2$   
 g  $1s^2 2s^2 2p^6 3s^2 3p^6 3d^{10} 4s^2 4p^5$   
 39 a 4 b i 3 ii 2,8,4  
 40 a i Period 2, Group 1 ii lithium, Li b i Period 3, Group 14  
 ii silicon, Si c i Period 2, Group 18 ii neon, Ne d i Period 4,  
 Group 1 ii potassium, K  
 41 K, Li and Cs 42 a 3 b 2 c 1 d 4 e 6  
 43 a argon b sulfur c chlorine d sodium e magnesium  
 44 a 8 b 1 c 7 d 5 e 2

## Chapter 2

- 1 physical changes: boiling water, wax melting, nail polish  
 remover evaporating, sugar dissolving in water; chemical  
 changes: cooking a cake, iron rusting, candle burning,  
 milk going sour, concrete setting.  
 2 Li and K, S and O, He and Ar, Cu and Au, Mg and Sr  
 3 a hydrogen b magnesium c platinum d aluminium  
 4 lose 2 electrons 5 xenon  
 6 same outer shell electron configuration 7  $\text{N}^{3-}$ ,  $\text{P}^{3-}$   
 9 a 1 proton, 0 electrons, charge +1 b 9 protons, 10 electrons,  
 charge -1 c 8 protons, 10 electrons, charge -2 d 13 protons,  
 10 electrons, charge +3  
 10 a 18 b 18 c 10 d 0 e 10 f 10  
 11 a  $\text{CuNO}_3$  b  $\text{Ag}_2\text{O}$  c  $\text{CrF}_3$  d  $\text{Li}_3\text{N}$  e  $\text{K}_2\text{CO}_3$   
 12 a potassium fluoride b lithium hydroxide c zinc chloride  
 d aluminium nitride e ammonium carbonate  
 14 a 0 b 3 c 0 d 1 e Ar does not form bonds  
 16 a O b C c N d N e F f F  
 18 i b-f, ii a, g, h

- 20 a i  $\text{H}_2$  ii  $\text{N}_2\text{O}$  iii  $\text{PH}_3$  iv  $\text{CCl}_4$  v  $\text{H}_2\text{S}$  b i fluorine gas ii nitrogen  
 dioxide iii carbon tetrahydride (methane) iv nitrogen trifluoride  
 v dinitrogen tetrahydride  
 31 a  $\text{CH}_4$ ;  $\text{C}_5\text{H}_{12}$ ;  $\text{C}_{25}\text{H}_{52}$  b  $\text{C}_3\text{H}_6$ ;  $\text{C}_6\text{H}_{12}$ ;  $\text{C}_5\text{H}_{10}$   
 37 a ionic substances b covalent substances c metals  
 40 metals, covalent molecular, ionic  
 42 a Li b As c Rb d Ca  
 43 a F b N c Na d S 44 D 45 D  
 46 a lithium and potassium b nitrogen and phosphorous  
 c magnesium and beryllium  
 47 C 48 B 49 C 50 B 51 B 52 B 53 A 54 C 55 B 56 D 57 C  
 58 a  $\text{Be}^{2+}$  b  $\text{O}^{2-}$  c  $\text{Na}^+$  d  $\text{P}^{3-}$  2,8,8  
 59 a i -3 ii +1 iii -2 b i  $\text{Y}_2\text{SO}_4$  ii  $\text{K}_2\text{Z}$  iii  $\text{Y}_3\text{X}$  iv  $\text{Y}_2\text{Z}$   
 61 a  $\text{Ba}(\text{NO}_2)_2$  b  $\text{Mg}(\text{HCO}_3)_2$  c  $\text{K}_2\text{HPO}_4$  d  $\text{Fe}_2(\text{SO}_3)_3$  e  $\text{Ni}_3(\text{PO}_4)_2$   
 62 a copper(II) nitrate b chromium(III) bromide c barium  
 hydrogen sulfate d lead(II) phosphate e iron(II) nitride  
 63 a  $\text{Ca}(\text{ClO}_4)_2$  b  $\text{Al}_4[\text{Fe}(\text{CN})_6]_3$  c  $\text{Fe}(\text{ClO}_4)_3$  d  $(\text{NH}_4)_4[\text{Fe}(\text{CN})_6]$   
 64 a  $\text{KBr}$  b  $\text{MgI}_2$  c  $\text{CaO}$  d  $\text{AlF}_3$  e  $\text{Ca}_3\text{N}_2$   
 65 C 66 B 67 A 68 C 69 D 70 B 71 C 72 C 73 D  
 74 a 1 b 2 c 3 d 4 e 1 f 0  
 76 a  $\text{H}_2$  b NO c  $\text{CS}_2$  d  $\text{CO}_2$   
 77 a 3, 2 b 4, 9 c 2, 4  
 79 b I  $\text{NH}_3$ ,  $\text{HCl}$ ,  $\text{H}_2\text{O}$ ,  $\text{CHCl}_3$  ii  $\text{N}_2$ ,  $\text{Cl}_2$ ,  $\text{O}_2$ ,  $\text{CH}_4$ ,  $\text{CO}_2$ ,  $\text{CCl}_4$   
 iii  $\text{NH}_3$ ,  $\text{H}_2\text{O}$  80 B.  $\text{H}_2\text{O}$   
 81  $\text{SO}_3$ : non-polar, dispersion forces;  $\text{SiCl}_4$ : non-polar,  
 dispersion forces;  $\text{CF}_4$ : non-polar, dispersion forces;  $\text{NF}_3$ : polar,  
 dipole-dipole interaction;  $\text{CH}_3\text{NH}_2$ : polar, hydrogen bonding  
 82  $\text{CCl}_4$  and  $\text{CO}_2$  84  $\text{Cl}_2$ ,  $\text{CCl}_4$ ,  $\text{NaCl}$  85 a  $\text{CCl}_4$   
 86 a dispersion forces b dispersion forces, dipole-dipole  
 interactions c dispersion forces, hydrogen bonding  
 d dispersion forces e dispersion forces, hydrogen bonding  
 f dispersion forces  
 87 B 88 C 89 C 90 A 91 C  
 92 a tungsten b too dense or heavy c potassium d too reactive,  
 especially in air and water  
 94 A 95 B 96 B 97 A 98 B 99 C 100 D 101 C 102 D 103 A  
 104 a ethene (ethylene) b octane c ethanol d propene  
 e n-hexane f propanoic acid g but-2-ene  
 106 a propane b but-2-ene c methylpropane  
 d 2,2-dimethylbutane  
 108  $\text{CH}_2=\text{CHCH}_2\text{CH}_3$   
 110 a cyclobutane b cyclopentene c 1,2-dimethylbenzene  
 d 2-phenylpropene  
 111  $\text{CH}_3\text{CH}(\text{OH})\text{CH}_3$   
 113 a boiling temperature increases b methane, ethane,  
 propane and butane  
 114 a  $\text{C}_3\text{H}_5\text{OH}$ ;  $\text{C}_4\text{H}_9\text{OH}$  (alcohols);  $\text{C}_3\text{H}_6$ ;  $\text{C}_3\text{H}_5\text{OH}$  (both  
 unsaturated) b  $\text{CH}_4$ ;  $\text{C}_2\text{H}_6$   
 117 D 118 B 119 B  
 122 a C b C c A d B  
 123 a i R, Y b i X c last electrons are filling the third shell  
 d i ionic bonding iii  $\text{QR}_2$

## Chapter 3

- 1 a  $28.0 \text{ g mol}^{-1}$  b  $17.0 \text{ g mol}^{-1}$  c  $98.1 \text{ g mol}^{-1}$  d  $242 \text{ g mol}^{-1}$   
 e  $60.0 \text{ g mol}^{-1}$  f  $32.1 \text{ g mol}^{-1}$  g  $257 \text{ g mol}^{-1}$  h  $250 \text{ g mol}^{-1}$   
 2 a 23.0 g b 64.0 g c 1.60 g d 25.5 g



**3 a** 5 mol **b** 2.5 mol **c** 0.10 mol **d** 0.025 mol **e** 0.0063 mol  
**f** 0.0031 mol **g**  $3.9 \times 10^{-5}$  mol **h**  $9.7 \times 10^{-6}$  mol  
**4 a** 0.10 mol **b** 0.1999 mol **c** 0.0391 mol **d** 0.0806 mol  
**e** 1.25 mol **f** 0.001 67 mol **g**  $3.4 \times 10^4$  mol  
**5 a** 40 g mol<sup>-1</sup> **b** 98 g mol<sup>-1</sup> **c** 44 g mol<sup>-1</sup> **d** 106 g mol<sup>-1</sup>  
**6 a**  $4.36 \times 10^{24}$  atoms **b**  $1.11 \times 10^{23}$  atoms  
**c**  $6.7 \times 10^{22}$  molecules  
**7 a** 144 g mol<sup>-1</sup> **b** 100 g mol<sup>-1</sup>.  
**8** s = solid; l = liquid; g = gas; aq = aqueous  
**9 a**  $2\text{CO(g)} + \text{O}_2\text{(g)} \rightarrow 2\text{CO}_2\text{(g)}$  **b**  $\text{N}_2\text{(g)} + 3\text{H}_2\text{(g)} \rightarrow 2\text{NH}_3\text{(g)}$   
**c**  $2\text{Na(s)} + \text{Cl}_2\text{(g)} \rightarrow 2\text{NaCl(s)}$  **d**  $2\text{SO}_2\text{(g)} + \text{O}_2\text{(g)} \rightarrow 2\text{SO}_3\text{(g)}$   
**e**  $\text{CH}_4\text{(g)} + 2\text{O}_2\text{(g)} \rightarrow \text{CO}_2\text{(g)} + 2\text{H}_2\text{O(g)}$  **f**  $2\text{C}_5\text{H}_{10}\text{(g)} + 15\text{O}_2\text{(g)} \rightarrow$   
 $10\text{CO}_2\text{(g)} + 10\text{H}_2\text{O(g)}$  **g**  $2\text{H}_2\text{S(g)} + 3\text{O}_2\text{(g)} \rightarrow 2\text{H}_2\text{O(g)} + 2\text{SO}_2\text{(g)}$   
**h**  $\text{P}_4\text{(s)} + 10\text{Cl}_2\text{(g)} \rightarrow 4\text{PCl}_5\text{(s)}$  **i**  $4\text{NH}_3\text{(g)} + 5\text{O}_2\text{(g)} \rightarrow 4\text{NO(g)} +$   
 $6\text{H}_2\text{O(g)}$  **j**  $\text{P}_4\text{O}_{10}\text{(s)} + 6\text{H}_2\text{O(l)} \rightarrow 4\text{H}_3\text{PO}_4\text{(aq)}$   
**10 a**  $\text{CH}_4\text{(g)} + 2\text{O}_2\text{(g)} \rightarrow \text{CO}_2\text{(g)} + 2\text{H}_2\text{O(g)}$  **b**  $2\text{C}_2\text{H}_6\text{(g)} + 7\text{O}_2\text{(g)} \rightarrow$   
 $4\text{CO}_2\text{(g)} + 6\text{H}_2\text{O(g)}$  **c**  $4\text{Fe(s)} + 3\text{O}_2\text{(g)} \rightarrow 2\text{Fe}_2\text{O}_3\text{(s)}$   
**d**  $\text{S(s)} + \text{O}_2\text{(g)} \rightarrow \text{SO}_2\text{(g)}$  **e**  $2\text{Mg(s)} + \text{O}_2\text{(g)} \rightarrow 2\text{MgO(s)}$   
**f**  $4\text{Al(s)} + 3\text{O}_2\text{(g)} \rightarrow 2\text{Al}_2\text{O}_3\text{(s)}$   
**11 a**  $2\text{H}_2\text{(g)} + \text{O}_2\text{(g)} \rightarrow 2\text{H}_2\text{O(g)}$  **b** 80 g  
**12 a** 800 g **b** 704 g  
**13 a** 2.03 g **b** 1.2 g **c** 0.82 g  
**14 a**  $\text{H}_2\text{S(g)} + 2\text{AgNO}_3\text{(aq)} \rightarrow \text{Ag}_2\text{S(s)} + 2\text{HNO}_3\text{(aq)}$  **b** 2.649 g  
**15 a** 15.7 g **b** 16.8 g  
**16 a** 1889 kg **b** 333.3 kg **c** 1222 kg  
**17 a**  $\text{MgSO}_4$ , 1.0 mol **b**  $\text{MgSO}_4$ , 1.5 mol **c**  $\text{Pb(NO}_3)_2$ , 2.8 mol  
**18 a**  $\text{Pb(NO}_3)_2$ , 0.50 mol **b**  $\text{Pb(NO}_3)_2$ , 1.8 mol **c** KI, 2.6 mol  
**19 a**  $\text{MgSO}_4$ , 0.64 g **b**  $\text{Pb(NO}_3)_2$ , 3.6 g **c**  $\text{MgSO}_4$ , 9.3 g  
**20** 92.2% **21** 79.6% **22** 74.3%  
**23 a** 55.8 g mol<sup>-1</sup> **b** 98.0 g mol<sup>-1</sup> **c** 62.0 g mol<sup>-1</sup> **d** 189.4 g mol<sup>-1</sup>  
**e** 75.0 g mol<sup>-1</sup> **f** 342 g mol<sup>-1</sup>  
**24 a** 98.0 g mol<sup>-1</sup> **b** 82.0 g mol<sup>-1</sup> **c** 357.4 g mol<sup>-1</sup> **d** 270.3 g mol<sup>-1</sup>  
**25 a** 1.8 g **b** 11 g **c** 3.6 g **d** 6.0 g **e** 6.1 g **f** 3.8 g  
**26 a**  $6.0 \times 10^{23}$  atoms **b**  $6.0 \times 10^{22}$  atoms **c**  $6.02 \times 10^{21}$  atoms  
**d**  $3.06 \times 10^{22}$  atoms  
**27 a**  $3.0 \times 10^{23}$  molecules **b**  $6.0 \times 10^{22}$  molecules **c**  $3.0 \times 10^{22}$   
molecules **d**  $2.44 \times 10^{24}$  molecules  
**28** iron **29 a**  $6.66 \times 10^{-23}$  g **b**  $3.0 \times 10^{-23}$  g **c**  $7.3 \times 10^{-23}$  g  
**30** 62.0 g  
**31 a** i 0.100 mol ii 0.100 mol  $\text{Na}^+$ , 0.100 mol  $\text{Cl}^-$  **b** i 0.405 mol  
ii 0.405 mol  $\text{Ca}^{2+}$ , 0.81 mol  $\text{Cl}^-$  **c** i 0.0026 mol ii 0.0026 mol  
 $\text{Al}^{3+}$ , 0.0078 mol  $\text{Cl}^-$  **d** i 0.004 20 mol ii 0.008 40 mol  $\text{Fe}^{3+}$ ,  
0.0126 mol  $\text{SO}_4^{2-}$  **e** i 1.72 mol ii 5.16 mol  $\text{K}^+$ , 1.72 mol  $\text{PO}_4^{3-}$   
**32 a** i 0.748 mol ii 13.5 g **b** i 15.0 mol ii 240 g **c** i  $6.0 \times 10^{-6}$  mol  
ii  $5.9 \times 10^{-4}$  g **d** i  $3.8 \times 10^4$  mol ii  $2.7 \times 10^6$  g **e** i  $1.7 \times 10^{-24}$  mol  
ii  $5.8 \times 10^{-22}$  g  
**33 a** i 0.56 mol ii  $3.4 \times 10^{23}$  molecules iii  $6.8 \times 10^{23}$  atoms  
**b** i 0.34 mol ii  $2.0 \times 10^{22}$  iii  $8.0 \times 10^{22}$  **c** i 0.292 mol  
ii  $1.76 \times 10^{23}$  iii  $1.41 \times 10^{24}$  **d** i 0.0088 mol ii  $5.3 \times 10^{21}$   
iii  $1.1 \times 10^{22}$  **e** i  $1.2 \times 10^{-4}$  mol ii  $7.2 \times 10^{19}$  iii  $1.7 \times 10^{21}$  **f** i  $9.1 \times$   
 $10^{-8}$  mol ii  $5.5 \times 10^{16}$  iii  $3.3 \times 10^{17}$   
**34 a** 8.0 g **b**  $3.76 \times 10^{21}$  molecules **c** 75% **d** 26 g  
**35 a**  $1.25 \times 10^4$  g mol<sup>-1</sup> **b**  $1.6 \times 10^{-7}$  mol **c**  $9.6 \times 10^{16}$  molecules  
**36 a**  $\text{SiCl}_4\text{(l)} + 2\text{H}_2\text{O(l)} \rightarrow \text{SiO}_2\text{(s)} + 4\text{HCl(aq)}$  **b**  $4\text{HCl(g)} + \text{O}_2\text{(g)} \rightarrow$   
 $2\text{H}_2\text{O(g)} + 2\text{Cl}_2\text{(g)}$  **c**  $\text{Fe}_2\text{O}_3\text{(s)} + 6\text{HCl(g)} \rightarrow 2\text{FeCl}_3\text{(aq)} + 3\text{H}_2\text{O(l)}$   
**d**  $4\text{MgO(s)} + 4\text{SO}_2\text{(g)} \rightarrow 3\text{MgSO}_4\text{(s)} + \text{MgS(s)}$   
**e**  $4\text{NH}_3\text{(g)} + 6\text{NO(g)} \rightarrow 6\text{H}_2\text{O(g)} + 5\text{N}_2\text{(g)}$   
**37 a**  $\text{O}_2\text{(g)} + 2\text{H}_2\text{(g)} \rightarrow 2\text{H}_2\text{O(l)}$  **b**  $\text{C(s)} + \text{O}_2\text{(g)} \rightarrow \text{CO}_2\text{(g)}$  **c**  $4\text{Na(l)}$   
 $+ \text{O}_2\text{(g)} \rightarrow 2\text{Na}_2\text{O(s)}$  **d**  $\text{P}_4\text{(s)} + 5\text{O}_2\text{(g)} \rightarrow \text{P}_4\text{O}_{10}\text{(g)}$  **e**  $\text{Mg(s)} + \text{Cl}_2\text{(g)}$

$\rightarrow \text{MgCl}_2\text{(s)}$  **f**  $2\text{C}_8\text{H}_{18}\text{(g)} + 25\text{O}_2\text{(g)} \rightarrow 16\text{CO}_2\text{(g)} + 18\text{H}_2\text{O(g)}$   
**g**  $2\text{H}_2\text{S(g)} + 3\text{O}_2\text{(g)} \rightarrow 2\text{H}_2\text{O(g)} + 2\text{SO}_2\text{(g)}$   
**38 a**  $2\text{Al(s)} + 3\text{F}_2\text{(g)} \rightarrow 2\text{AlF}_3\text{(s)}$  **b**  $\text{S(s)} + \text{O}_2\text{(g)} \rightarrow \text{SO}_2\text{(g)}$  **c**  $\text{C(s)} +$   
 $\text{O}_2\text{(g)} \rightarrow \text{CO}_2\text{(g)}$  **d**  $\text{H}_2\text{(g)} + \text{Cl}_2\text{(g)} \rightarrow 2\text{HCl(g)}$   
**39 a**  $\text{H}_2\text{(g)} + \text{F}_2\text{(g)} \rightarrow 2\text{HF(l)}$  **b**  $\text{C}_2\text{H}_4\text{(g)} + 3\text{O}_2\text{(g)} \rightarrow 2\text{CO}_2\text{(g)} +$   
 $2\text{H}_2\text{O(l)}$  **c**  $\text{Zn(s)} + 2\text{HNO}_3\text{(aq)} \rightarrow \text{H}_2\text{(g)} + \text{Zn(NO}_3)_2\text{(aq)}$  **d**  $2\text{PbS}_2\text{(s)}$   
 $+ \text{O}_2\text{(g)} \rightarrow 2\text{PbO} + 4\text{S(s)}$   
**40** 1.1 kg  
**41 a**  $\text{K}_2\text{CrO}_4\text{(aq)} + \text{Pb(NO}_3)_2\text{(aq)} \rightarrow \text{PbCrO}_4\text{(s)} + 2\text{KNO}_3\text{(aq)}$   
**b** 3.6 g  
**42** 230 g **43** 40.8 g **44 a** 20.1 g **b** 24.3 g **c** 10.9 g **45** 62 kg  
**46 a** 100 tonnes **b** 120 tonnes **c** 64.0 tonnes  
**48 a** i 0.000 01 mol  $\text{Pb(NO}_3)_2$  ii 1.39 g **b** i 0.012 04 mol KI  
ii 0.84 g **c** i 0.006 045 mol  $\text{Pb(NO}_3)_2$  ii 0.83 g  
**d** i 0.029 mol KI ii 0.28 g  
**49 A** 51 64.2% **52** 63.4%  
**53**  $4.16 \times 10^3$  g of chromium is produced.

## Chapter 4

**1**  $\text{CH}_3\text{OH(l)} \xrightarrow{\text{H}_2\text{O}} \text{CH}_3\text{OH(aq)}$ ;  $\text{C}_6\text{H}_{12}\text{O}_6\text{(s)} \xrightarrow{\text{H}_2\text{O}} \text{C}_6\text{H}_{12}\text{O}_6\text{(aq)}$   
**2**  $\text{HNO}_3\text{(l)} + \text{H}_2\text{O(l)} \rightarrow \text{H}_3\text{O}^+\text{(aq)} + \text{NO}_3^-\text{(aq)}$ ;  $\text{HF(g)} + \text{H}_2\text{O(l)} \rightarrow$   
 $\text{H}_3\text{O}^+\text{(aq)} + \text{F}^-\text{(aq)}$   
**3**  $\text{NaNO}_3\text{(s)} \xrightarrow{\text{H}_2\text{O}} \text{Na}^+\text{(aq)} + \text{NO}_3^-\text{(aq)}$ ;  $\text{Ca(OH)}_2\text{(s)} \xrightarrow{\text{H}_2\text{O}}$   
 $\text{Ca}^{2+}\text{(aq)} + 2\text{OH}^-\text{(aq)}$   
**4** a, b, d **5** b, c  
**6 a**  $\text{Mg}^{2+}\text{(aq)}$  and  $\text{HCO}_3^-\text{(aq)}$  **b**  $\text{Ca}^{2+}\text{(aq)}$  and  $\text{NO}_3^-\text{(aq)}$  **c**  $\text{K}^+\text{(aq)}$   
and  $\text{HSO}_4^-\text{(aq)}$  **d**  $\text{Fe}^{3+}\text{(aq)}$  and  $\text{SO}_4^{2-}\text{(aq)}$  **e**  $\text{Cu}^{2+}\text{(aq)}$  and  $\text{Cl}^-\text{(aq)}$   
**7** b, d **9 a** 32°C **b** 55°C **c** 68°C  
**10 a** 84 g/100 g **b** 36 g/100 g **c** 38 g/100g  
**11 a** 25 g **b** 65 g **c** 100 g  
**12 a** 42 g **b** 96 g **c** 184 g  
**13** 14 g **14** No **15** 35 g **16** 45 g **17** 1.29 g **18** 60 kg  
**19 a** 0.48 M **b** 0.050 M **c** 0.08 M **d** 0.30 M  
**20 a** 1.0 M **b** 1.6 M **c** 0.05 M **d** 0.0019 M  
**21 a** 0.50 M **b** 0.40 M **c** 3.5 M **d**  $7 \times 10^{-2}$  M  
**22 a** 2.0 mol **b** 4.0 mol **c** 0.20 mol **d**  $2.0 \times 10^2$  mol (or 200 mol)  
**e**  $7.4 \times 10^3$  mol (or 7400 mol)  
**23 a** 360 g **b** 720 g **c** 36 g **d**  $3.60 \times 10^4$  g **e**  $1.3 \times 10^6$  g  
**24 a** 2.0 mol **b** 0.5 mol **c** 1.0 mol **d**  $3.0 \times 10^2$  mol **e**  $7.8 \times 10^3$  mol  
**25 a** 0.022 mol **b** 0.0022 mol **c** 0.000 41 mol **d**  $2.34 \times 10^{-4}$  mol  
**e** 0.0014 mol **f**  $7.8 \times 10^{-4}$  mol  
**26 a** 0.4 M **b** 0.10 M **c** 2 M **d** 0.025 M  
**27 A** **28 D** **29 C** **30 A** **31 A** **32 D** **33 D**  
**34** a, b, f  
**35 a**  $\text{CuSO}_4$ ,  $\text{Na}_2\text{SO}_4$ ,  $\text{K}_2\text{SO}_4$  **b**  $\text{CaSO}_4$ ,  $\text{Ag}_2\text{SO}_4$ ,  $\text{PbSO}_4$   
**36 a**  $(\text{NH}_4)_2\text{CO}_3$ ,  $\text{Na}_2\text{CO}_3$ ,  $\text{K}_2\text{CO}_3$  **b**  $\text{CaCO}_3$ ,  $\text{Ag}_2\text{CO}_3$ ,  $\text{PbCO}_3$   
**37 a** soluble **b** insoluble **c** insoluble **d** soluble **e** insoluble  
**f** soluble  
**39 a**  $\text{Na}_3\text{PO}_4\text{(s)} \rightarrow 3\text{Na}^+\text{(aq)} + \text{PO}_4^{3-}\text{(aq)}$  **b**  $\text{AlCl}_3\text{(s)} \rightarrow \text{Al}^{3+}\text{(aq)} +$   
 $3\text{Cl}^-\text{(aq)}$  **c**  $\text{CuSO}_4\text{(s)} \rightarrow \text{Cu}^{2+}\text{(aq)} + \text{SO}_4^{2-}\text{(aq)}$  **d**  $\text{KOH(s)} \rightarrow \text{K}^+\text{(aq)}$   
 $+ \text{OH}^-\text{(aq)}$  **e**  $(\text{CH}_3\text{COO})_2\text{Ca(s)} \rightarrow 2\text{CH}_3\text{COO}^-\text{(aq)} + \text{Ca}^{2+}\text{(aq)}$   
**f**  $(\text{NH}_4)_2\text{SO}_4\text{(s)} \rightarrow 2\text{NH}_4^+\text{(aq)} + \text{SO}_4^{2-}\text{(aq)}$  **g**  $\text{NaHCO}_3\text{(s)} \rightarrow \text{Na}^+\text{(aq)}$   
 $+ \text{HCO}_3^-\text{(aq)}$   
**40 a** alcohols  
**41 a** i 2,8,8,1 or  $1s^2 2s^2 2p^6 3s^2 3p^6 4s^1$  ii 2,8,7 or  
 $1s^2 2s^2 2p^6 3s^2 2p^5$  **c** ii  $\text{KCl(s)} \xrightarrow{\text{H}_2\text{O}} \text{K}^+\text{(aq)} + \text{Cl}^-\text{(aq)}$   
**f** i 35.0 g per 100 g water ii 260 g L<sup>-1</sup> **g** less soluble



43 a 60 g/100 g b i lead nitrate ii potassium nitrate c 240 g  
 d 200 g e i saturated ii saturated iii supersaturated  
 iv unsaturated f 5 g h i 15 g ii 27 g i i 53°C ii 9°C  
 44 b 73.6 g c i unsaturated ii 57 g d i 55 g ii 30 g iii 45°C  
 iv 30 g NaCl, 23.0 g CsNO<sub>3</sub>  
 45 b 64 g/100 g c wearing goggles; wearing laboratory coat;  
 taking care when handling potassium dichromate; not allowing  
 the solid itself to be heated  
 47 D 48 B  
 49 a 0.63 M b 1.3 M c 0.49 M d 5.0 × 10<sup>-3</sup> M e 0.042 M  
 50 a 2.00 mol b 1 mol c 0.500 mol d 0.002 mol  
 e 0.0043 mol  
 51 a 70.2 g b 0.001 76 g  
 52 a i 0.0013 mol (or 1.3 × 10<sup>-3</sup> mol) ii 0.0013 mol (or 1.3 × 10<sup>-3</sup>  
 mol) iii 0.0038 mol (or 3.8 × 10<sup>-3</sup> mol) iv 3.0 × 10<sup>21</sup>  
 b i 0.000 49 mol (or 4.9 × 10<sup>-4</sup> mol) ii 0.000 49 mol (or 4.9 ×  
 10<sup>-4</sup> mol) iii 0.0015 mol (or 1.5 × 10<sup>-3</sup> mol) iv 1.2 × 10<sup>21</sup>  
 53 a neither b second solution c first solution  
 54 7.5 mL 55 0.0075 mol  
 56 a 0.20 M b 0.20 M c 0.44 M d 0.46 M

## Chapter 5

5 0.21 atmospheres  
 6 a 1900 mm Hg, 252.5 kPa b 73 000 Pa, 0.72 atm  
 c 1091 mmHg, 1.45 bars d 0.67 atm, 68 kPa  
 7 a 1200 mL b 65 cm<sup>3</sup> c 2700 mL d 5.5 × 10<sup>-4</sup> m<sup>3</sup> e 5.4 × 10<sup>-3</sup> m<sup>3</sup>  
 f 650 cm<sup>3</sup>  
 8 450 mmHg 9 2.1 atm. 10 214 mL 11 0.4 atm 12 1.55 atm.  
 13 a 238 K b 300 K c 373 K d 273 K  
 14 a 100°C b -263°C c -173°C d -273°C  
 15 18.0 L 16 a 1.7 L b 1.3 L 17 a 73°C b -215.4°C 18 163°C  
 19 a 102 kPa b 130 kPa c 91.7 kPa  
 20 14.3 L 21 6.23 moles 22 0.56 grams. 23 633°C  
 24 27.3 L 25 15.6 L 26 1494°C 27 158 kPa 28 11.9 L  
 29 -198°C 30 0.42 g 31 balloon B  
 32 a 13 L b 6.13 L 33 a 19 L b 7.8 L  
 34 a 93.3 g b 0.024 g 35 9.29 × 10<sup>-2</sup> L.  
 36 600 L 37 3.00 g 38 37.2 g 43 1.2 atm  
 44 a 7575 kPa b 90.4 kPa  
 45 a 0.023 L b 0.085 L c 7.25 × 10<sup>-4</sup> m<sup>3</sup>  
 46 a 278 K b 122°C c -263°C d 178 K  
 47 a 475 kPa b 13.6 kPa  
 48 5.69 L 49 74.8 kPa 50 78 51 156 kPa 52 6.00 L  
 53 a 2.35 moles b 103 g  
 54 a high temperatures and low pressures  
 55 231 kPa 56 20.3 L 57 828 K 58 17.0 g  
 60 a 13.5 L b 0.610 L 61 a 37.5 g b 0.492 g  
 62 a 30.6 g mol<sup>-1</sup> b oxygen 63 1.70 L 64 2.68 g 65 277 L  
 66 a 0.56 g b 0.83 g of lithium

## Chapter 6

1 a single replacement b combination c decomposition  
 d combination e double replacement f single replacement  
 g single replacement h decomposition  
 2 a O<sub>2</sub> b FeBr<sub>2</sub> c CaBr<sub>2</sub> d BaO e Al f H<sub>2</sub>  
 3 a Ag<sub>2</sub>S b ZnCO<sub>3</sub> c Fe(OH)<sub>3</sub> d no precipitate will form e MgCO<sub>3</sub>  
 4 a Ag<sub>2</sub>SO<sub>4</sub>(s) + 2HNO<sub>3</sub>(aq) b PbI<sub>2</sub>(s) + 2NaNO<sub>3</sub>(aq) c Ag<sub>2</sub>S(s) +  
 2NaNO<sub>3</sub>(aq) d BaSO<sub>4</sub>(s) + 2NaCl(aq) e Pb(OH)<sub>2</sub>(s) + 2KNO<sub>3</sub>(aq)

5 a (NH<sub>4</sub>)<sub>2</sub>SO<sub>4</sub>(aq) + BaCl<sub>2</sub>(aq) → BaSO<sub>4</sub>(s) + 2NH<sub>4</sub>Cl(aq)  
 b K<sub>2</sub>S(aq) + Pb(NO<sub>3</sub>)<sub>2</sub>(aq) → PbS(s) + 2KNO<sub>3</sub>(aq) c CuSO<sub>4</sub>(aq) +  
 Na<sub>2</sub>CO<sub>3</sub>(aq) → CuCO<sub>3</sub>(s) + Na<sub>2</sub>SO<sub>4</sub>(aq) d 2Na<sub>3</sub>PO<sub>4</sub>(aq) +  
 3Ca(NO<sub>3</sub>)<sub>2</sub>(aq) → Ca<sub>3</sub>(PO<sub>4</sub>)<sub>2</sub>(s) + 6NaNO<sub>3</sub>(aq)  
 6 a Cu(NO<sub>3</sub>)<sub>2</sub>(s) → Cu<sup>2+</sup>(aq) + 2NO<sub>3</sub><sup>-</sup>(aq) b Na<sub>3</sub>PO<sub>4</sub>(s) →  
 3Na<sup>+</sup>(aq) + PO<sub>4</sub><sup>3-</sup>(aq) c K<sub>2</sub>CO<sub>3</sub>(s) → 2K<sup>+</sup>(aq) + CO<sub>3</sub><sup>2-</sup>(aq)  
 d Li<sub>2</sub>SO<sub>4</sub>(s) → 2Li<sup>+</sup>(aq) + SO<sub>4</sub><sup>2-</sup>(aq) e AgNO<sub>3</sub>(s) → Ag<sup>+</sup>(aq) +  
 NO<sub>3</sub><sup>-</sup>(aq) f FeCl<sub>2</sub>(s) → Fe<sup>2+</sup>(aq) + 2Cl<sup>-</sup>(aq)  
 7 a Ag<sup>+</sup>(aq) + NO<sub>3</sub><sup>-</sup>(aq) + Na<sup>+</sup>(aq) + Cl<sup>-</sup>(aq) → AgCl(s) + Na<sup>+</sup>(aq)  
 + NO<sub>3</sub><sup>-</sup>(aq) b 2K<sup>+</sup>(aq) + CO<sub>3</sub><sup>2-</sup>(aq) + Ca<sup>2+</sup>(aq) + 2NO<sub>3</sub><sup>-</sup>(aq) →  
 CaCO<sub>3</sub>(s) + 2K<sup>+</sup>(aq) + 2NO<sub>3</sub><sup>-</sup>(aq) c 6K<sup>+</sup>(aq) + 2PO<sub>4</sub><sup>3-</sup>(aq) +  
 3Pb<sup>2+</sup>(aq) + 6NO<sub>3</sub><sup>-</sup>(aq) → Pb<sub>3</sub>(PO<sub>4</sub>)<sub>2</sub>(s) + 6K<sup>+</sup>(aq) + 6NO<sub>3</sub><sup>-</sup>(aq)  
 d Mg<sup>2+</sup>(aq) + 2Cl<sup>-</sup>(aq) + 2Ag<sup>+</sup>(aq) + 2NO<sub>3</sub><sup>-</sup>(aq) → 2AgCl(s) +  
 Mg<sup>2+</sup>(aq) + 2NO<sub>3</sub><sup>-</sup>(aq) e Cu<sup>2+</sup>(aq) + 2Cl<sup>-</sup>(aq) + 2Li<sup>+</sup>(aq) +  
 2OH<sup>-</sup>(aq) → Cu(OH)<sub>2</sub>(s) + 2Li<sup>+</sup>(aq) + 2Cl<sup>-</sup>(aq) f 6NH<sub>4</sub><sup>+</sup>(aq) +  
 2PO<sub>4</sub><sup>3-</sup>(aq) + 3Zn<sup>2+</sup>(aq) + 3SO<sub>4</sub><sup>2-</sup>(aq) → Zn<sub>3</sub>(PO<sub>4</sub>)<sub>2</sub>(s) +  
 6NH<sub>4</sub><sup>+</sup>(aq) + 3SO<sub>4</sub><sup>2-</sup>(aq)  
 8 a Ag<sup>+</sup>(aq) + NO<sub>3</sub><sup>-</sup>(aq) + Na<sup>+</sup>(aq) + Br<sup>-</sup>(aq) → AgBr(s) + Na<sup>+</sup>(aq)  
 + NO<sub>3</sub><sup>-</sup>(aq); Ag<sup>+</sup>(aq) + Br<sup>-</sup>(aq) → AgBr(s) b Hg<sup>2+</sup>(aq) + 2NO<sub>3</sub><sup>-</sup>(aq)  
 + 2K<sup>+</sup>(aq) + 2I<sup>-</sup>(aq) → HgI<sub>2</sub>(s) + 2K<sup>+</sup>(aq) + 2NO<sub>3</sub><sup>-</sup>(aq); Hg<sup>2+</sup>(aq) +  
 2I<sup>-</sup>(aq) → HgI<sub>2</sub>(s) c Sr<sup>2+</sup>(aq) + 2Cl<sup>-</sup>(aq) + 2NH<sub>4</sub><sup>+</sup>(aq) + SO<sub>4</sub><sup>2-</sup>(aq)  
 → SrSO<sub>4</sub>(s) + 2NH<sub>4</sub><sup>+</sup>(aq) + 2Cl<sup>-</sup>(aq); Sr<sup>2+</sup>(aq) + SO<sub>4</sub><sup>2-</sup>(aq) →  
 SrSO<sub>4</sub>(s) d Ba<sup>2+</sup>(aq) + 2OH<sup>-</sup>(aq) + 2Na<sup>+</sup>(aq) + CO<sub>3</sub><sup>2-</sup>(aq) →  
 BaCO<sub>3</sub>(s) + 2Na<sup>+</sup>(aq) + 2OH<sup>-</sup>(aq); Ba<sup>2+</sup>(aq) + CO<sub>3</sub><sup>2-</sup>(aq) →  
 BaCO<sub>3</sub>(s) e 3Mg<sup>2+</sup>(aq) + 6Cl<sup>-</sup>(aq) + 6Li<sup>+</sup>(aq) + 2PO<sub>4</sub><sup>3-</sup>(aq) →  
 Mg<sub>3</sub>(PO<sub>4</sub>)<sub>2</sub>(s) + 6Li<sup>+</sup>(aq) + 6Cl<sup>-</sup>(aq); 3Mg<sup>2+</sup>(aq) + 2PO<sub>4</sub><sup>3-</sup>(aq) →  
 Mg<sub>3</sub>(PO<sub>4</sub>)<sub>2</sub>(s) f 2Na<sup>+</sup>(aq) + 2OH<sup>-</sup>(aq) + Fe<sup>2+</sup>(aq) + 2NO<sub>3</sub><sup>-</sup>(aq) →  
 Fe(OH)<sub>2</sub>(s) + 2Na<sup>+</sup>(aq) + 2NO<sub>3</sub><sup>-</sup>(aq); Fe<sup>2+</sup>(aq) + 2OH<sup>-</sup>(aq) →  
 Fe(OH)<sub>2</sub>(s)  
 9 a Pb<sup>2+</sup>(aq) + 2 Cl<sup>-</sup>(aq) → PbCl<sub>2</sub>(s) b Ba<sup>2+</sup>(aq) + SO<sub>4</sub><sup>2-</sup>(aq) →  
 BaSO<sub>4</sub>(s) c Ba<sup>2+</sup>(aq) + SO<sub>4</sub><sup>2-</sup>(aq) → BaSO<sub>4</sub>(s) d 2Ag<sup>+</sup>(aq) +  
 SO<sub>4</sub><sup>2-</sup>(aq) → Ag<sub>2</sub>SO<sub>4</sub>(s) e Hg<sup>2+</sup>(aq) + SO<sub>4</sub><sup>2-</sup>(aq) → HgSO<sub>4</sub>(s)  
 f Ca<sup>2+</sup>(aq) + CO<sub>3</sub><sup>2-</sup>(aq) → CaCO<sub>3</sub>(s)  
 10 a combination b decomposition c double replacement  
 d single replacement e single replacement f double  
 replacement  
 11 a 2Na(s) b 2KNO<sub>3</sub>(aq) c O<sub>2</sub>(g) d 2Hg(l)  
 12 a BaSO<sub>4</sub> b Ag<sub>2</sub>SO<sub>4</sub> c Zn(OH)<sub>2</sub> d Al<sub>2</sub>S<sub>3</sub> e CuS  
 14 a AgNO<sub>3</sub>(aq) + NH<sub>4</sub>Br(aq) → AgBr(s) + NH<sub>4</sub>NO<sub>3</sub>(aq)  
 b 2NaOH(aq) + NiCl<sub>2</sub>(aq) → Ni(OH)<sub>2</sub>(s) + 2NaCl(aq) c MgBr<sub>2</sub>(aq)  
 + K<sub>2</sub>CO<sub>3</sub>(aq) → MgCO<sub>3</sub>(s) + 2KBr(aq) d Na<sub>2</sub>SO<sub>4</sub>(aq) + 2AgF(aq)  
 → Ag<sub>2</sub>SO<sub>4</sub>(s) + 2NaF(aq) e CaCl<sub>2</sub>(aq) + Na<sub>2</sub>CO<sub>3</sub>(aq) → CaCO<sub>3</sub>(s)  
 + 2NaCl(aq)  
 15 a CuCl<sub>2</sub>(s) → Cu<sup>2+</sup>(aq) + 2Cl<sup>-</sup>(aq) b KOH(s) → K<sup>+</sup>(aq) +  
 OH<sup>-</sup>(aq) c BaS(s) → Ba<sup>2+</sup>(aq) + S<sup>2-</sup>(aq) d (NH<sub>4</sub>)<sub>2</sub>CO<sub>3</sub>(s) →  
 2NH<sub>4</sub><sup>+</sup>(aq) + CO<sub>3</sub><sup>2-</sup>(aq) e MgBr<sub>2</sub>(s) → Mg<sup>2+</sup>(aq) + 2Br<sup>-</sup>(aq)  
 16 a Ag<sup>+</sup>(aq) + NO<sub>3</sub><sup>-</sup>(aq) + K<sup>+</sup>(aq) + Cl<sup>-</sup>(aq) → AgCl(s) + K<sup>+</sup>(aq) +  
 NO<sub>3</sub><sup>-</sup>(aq) b Ni<sup>2+</sup>(aq) + 2Cl<sup>-</sup>(aq) + Mg<sup>2+</sup>(aq) + S<sup>2-</sup>(aq) → NiS(s) +  
 Mg<sup>2+</sup>(aq) + 2Cl<sup>-</sup>(aq) c 2Li<sup>+</sup>(aq) + 2OH<sup>-</sup>(aq) + Mg<sup>2+</sup>(aq) + 2Cl<sup>-</sup>(aq)  
 → Mg(OH)<sub>2</sub>(s) + 2Li<sup>+</sup>(aq) + 2Cl<sup>-</sup>(aq) d 2Na<sup>+</sup>(aq) + 2Cl<sup>-</sup>(aq) +  
 Hg<sup>2+</sup>(aq) + 2NO<sub>3</sub><sup>-</sup>(aq) → HgCl<sub>2</sub>(s) + 2Na<sup>+</sup>(aq) + 2NO<sub>3</sub><sup>-</sup>(aq)  
 e Ca<sup>2+</sup>(aq) + 2Cl<sup>-</sup>(aq) + 2K<sup>+</sup>(aq) + CO<sub>3</sub><sup>2-</sup>(aq) → CaCO<sub>3</sub>(s) +  
 2K<sup>+</sup>(aq) + 2Cl<sup>-</sup>(aq)  
 17 a 2Ag<sup>+</sup>(aq) + CO<sub>3</sub><sup>2-</sup>(aq) → Ag<sub>2</sub>CO<sub>3</sub>(s) b Mg<sup>2+</sup>(aq) + 2OH<sup>-</sup>(aq)  
 → Mg(OH)<sub>2</sub>(s) c Sr<sup>2+</sup>(aq) + SO<sub>4</sub><sup>2-</sup>(aq) → SrSO<sub>4</sub>(s) d Ca<sup>2+</sup>(aq) +  
 CO<sub>3</sub><sup>2-</sup>(aq) → CaCO<sub>3</sub>(s) e Pb<sup>2+</sup>(aq) + 2Br<sup>-</sup>(aq) → PbBr<sub>2</sub>(s)  
 18 a K<sup>+</sup>, NO<sub>3</sub><sup>-</sup> b Li<sup>+</sup>, Cl<sup>-</sup> c Na<sup>+</sup>, Cl<sup>-</sup> d Na<sup>+</sup>, Cl<sup>-</sup> e K<sup>+</sup>, NO<sub>3</sub><sup>-</sup>



## Chapter 7

- 1 **a**  $2\text{C}_2\text{H}_6(\text{g}) + 7\text{O}_2(\text{g}) \rightarrow 4\text{CO}_2(\text{g}) + 6\text{H}_2\text{O}(\text{g})$   
**b**  $2\text{Mg}(\text{s}) + \text{O}_2(\text{g}) \rightarrow 2\text{MgO}(\text{s})$  **c**  $4\text{Na}(\text{s}) + \text{O}_2(\text{g}) \rightarrow 2\text{Na}_2\text{O}(\text{s})$   
**d**  $\text{CH}_3\text{CH}_2\text{CH}_2\text{OH} + 5\text{O}_2(\text{g}) \rightarrow 3\text{CO}_2(\text{g}) + 4\text{H}_2\text{O}(\text{g})$   
**2** During oxidation of a metal, oxygen atoms (or some other element) combine with the metal, giving increased mass compared to the uncombined metal.  
**3** Lead(II) oxide is being reduced as oxygen is being removed and carbon is being oxidised as it combines with oxygen.  
**4**  $\text{CuS}(\text{s}) + \text{O}_2(\text{g}) \rightarrow \text{Cu}(\text{s}) + \text{SO}_2(\text{g})$ ;  $\text{SO}_3$  may also be a product.  
**5 a** oxidation **b** reduction **c** oxidation **d** reduction  
**6 a** Mg to  $\text{Mg}^{2+}$  **b**  $\text{Cu}^{2+}$  to Cu **c**  $\text{Cu}^{2+}$  **d** Mg  
**8 a**  $\text{S}(\text{s}) + \text{O}_2(\text{g}) \rightarrow \text{SO}_2(\text{g})$   
**9 a**  $2\text{H}_2(\text{g}) + \text{O}_2(\text{g}) \rightarrow 2\text{H}_2\text{O}(\text{g})$  **c** hydrogen is oxidised, oxygen is reduced **d** oxidant is oxygen, reductant is hydrogen  
**10 a** 4, -2 **b** 4, -2 **c** 0 **d** 7, -2 **e** 6, -2 **f** 3, -2 **g** 1, 5, -2  
**h** 1, 5, -2 **i** -4, 1 **j** 4, -2  
**11**  $\text{ClO}_4^-$   
**12 a, b** and **d** are redox reactions  
**13 a**  $2\text{Na}(\text{s}) + \text{Cl}_2(\text{g}) \rightarrow 2\text{NaCl}(\text{s})$   
**b**  $\text{Cu}(\text{s}) + 2\text{NO}_3^-(\text{aq}) + 4\text{H}^+(\text{aq}) \rightarrow \text{Cu}^{2+}(\text{aq}) + 2\text{NO}_2(\text{g}) + 2\text{H}_2\text{O}(\text{l})$   
**c**  $2\text{NO}_3^-(\text{aq}) + 3\text{H}_2\text{S}(\text{g}) + 2\text{H}^+(\text{aq}) \rightarrow 3\text{S}(\text{s}) + 2\text{NO}(\text{g}) + 4\text{H}_2\text{O}(\text{l})$   
**d**  $\text{Cr}_2\text{O}_7^{2-}(\text{aq}) + 3\text{Pb}^{2+}(\text{aq}) + 14\text{H}^+(\text{aq}) \rightarrow 2\text{Cr}^{3+}(\text{aq}) + 3\text{Pb}^{4+}(\text{aq}) + 7\text{H}_2\text{O}(\text{l})$   
**14 a**  $3\text{Cu}^{2+}(\text{aq}) + 2\text{Fe}(\text{s}) \rightarrow 3\text{Cu}(\text{s}) + 2\text{Fe}^{3+}(\text{aq})$   
**b**  $\text{Cu}(\text{s}) + 2\text{NO}_3^-(\text{aq}) + 4\text{H}^+(\text{aq}) \rightarrow \text{Cu}^{2+}(\text{aq}) + 2\text{NO}_2(\text{g}) + 2\text{H}_2\text{O}(\text{l})$   
**c**  $\text{ClO}_3^-(\text{aq}) + 6\text{Br}^-(\text{aq}) + 6\text{H}^+(\text{aq}) \rightarrow \text{Cl}^-(\text{aq}) + 3\text{Br}_2(\text{g}) + 3\text{H}_2\text{O}(\text{l})$   
**d**  $2\text{MnO}_4^-(\text{aq}) + 5\text{SO}_2(\text{g}) + 2\text{H}_2\text{O}(\text{l}) \rightarrow 2\text{Mn}^{2+}(\text{aq}) + 5\text{SO}_4^{2-}(\text{aq}) + 4\text{H}^+(\text{aq})$   
**15** +1.52 V  
**18 a** No, -0.53 V **b** No, -1.51 V **c** No, -0.34 V **d** Yes, 2.09 V  
**19 a** Sn or Ni **b**  $\text{MnO}_4^-/\text{H}^+$  or  $\text{HClO}/\text{H}^+$  **c** Mn or below on the table of reduction potentials will reduce water to hydrogen gas. Zn or above on the table of reduction potentials will not reduce water to hydrogen gas.  
**20**

	Anode	Cathode	Reaction	Minimum voltage
<b>a</b>	$\text{I}_2$	Cu	$\text{Cu}^{2+} + 2\text{I}^- \rightarrow \text{Cu} + \text{I}_2$	0.20 V
<b>b</b>	$\text{Br}_2$	$\text{H}_2$	$2\text{H}^+ + 2\text{Br}^- \rightarrow \text{H}_2 + \text{Br}_2$	1.06 V
<b>c</b>	$\text{Ag}^+$	Ag	$\text{Ag} + \text{Ag}^+ \rightarrow \text{Ag}^+ + \text{Ag}$	0.00 V

**22**  $1.8 \times 10^4 \text{ C}$   
**23** 2.015 tonnes per day  
**24** 0.087 L of  $\text{O}_2$   
**25**  $M = 183.9 \text{ g mol}^{-1}$   
**26**  $t = 14.8 \text{ h}$   
**27**  $m(\text{Sn}) = 1.10 \text{ g}$   
**28** Al has been oxidised, O has been reduced  
**29 a**  $2\text{Fe}(\text{s}) + 3\text{S}(\text{s}) \rightarrow 2\text{Fe}^{3+}(\text{aq}) + 3\text{S}^{2-}(\text{aq})$  or  $2\text{Fe}(\text{s}) + 3\text{S}(\text{s}) \rightarrow \text{FeS}_3(\text{s})$   
**b** S is oxidant, Fe is reductant  
**30 a**  $\text{Cu}(\text{s}) + 2\text{NO}_3^-(\text{aq}) + 4\text{H}^+(\text{aq}) \rightarrow 2\text{NO}_2(\text{g}) + 2\text{H}_2\text{O}(\text{l})$   
**b**  $2\text{Fe}(\text{s}) + 3\text{Pb}^{2+}(\text{aq}) \rightarrow 2\text{Fe}^{3+}(\text{aq}) + 3\text{Pb}(\text{s})$   
**c**  $\text{Cr}_2\text{O}_7^{2-}(\text{aq}) + \text{SO}_3^{2-}(\text{aq}) + 8\text{H}^+(\text{aq}) \rightarrow 2\text{Cr}^{3+}(\text{aq}) + \text{SO}_4^{2-}(\text{aq}) + 4\text{H}_2\text{O}(\text{l})$   
**d**  $2\text{Al}(\text{s}) + 3\text{Ag}_2\text{S}(\text{s}) \rightarrow 6\text{Ag}(\text{s}) + \text{Al}_2\text{S}_3(\text{s})$   
**31 a** +5 **b** +4 **c** -3 **d** +2 **e** -2 **f** +4 **g** +4 **h** +6  
**32 a**  $5\text{SO}_2(\text{g}) + 2\text{MnO}_4^-(\text{aq}) + 2\text{H}_2\text{O}(\text{l}) \rightarrow 5\text{SO}_4^{2-}(\text{aq}) + 2\text{Mn}^{2+}(\text{aq}) + 4\text{H}^+(\text{aq})$

**c** 0.011 05 M

- 33 a** Yes,  $\text{Cl}_2(\text{aq}) + 2\text{Br}^-(\text{aq}) \rightarrow 2\text{Cl}^-(\text{aq}) + \text{Br}_2(\text{aq})$ ,  $E(\text{cell})$  is positive **b** Yes,  $\text{F}_2(\text{aq}) + 2\text{Cl}^-(\text{aq}) \rightarrow 2\text{F}^-(\text{aq}) + \text{Cl}_2(\text{aq})$ ,  $E(\text{cell})$  is positive **c** No  $E(\text{cell})$  is negative  
**34** A halogen will displace a halide ion from aqueous solution if it is lower than the halogen on Group 17 of the periodic table.  
**35 a** K, Na, Ca, Mg, Al  
**b** K, Na, Ca, Mg, Al, Zn, Fe  
**c** K, Na, Ca, Mg, Al, Zn, Fe, Cu, Hg, Ag  
**36 b**  $3\text{Cu}^{2+}(\text{aq}) + 2\text{Al}(\text{s}) \rightarrow 3\text{Cu}(\text{s}) + 2\text{Al}^{3+}(\text{aq})$   
**c** 5648 g of Cu (5.648 kg)  
**37 a** In beaker A  
**b**  $\text{Pb}^{2+}(\text{aq}) + 2\text{e}^- \rightarrow \text{Pb}(\text{s})$ ;  $\text{Ni}(\text{s}) \rightarrow \text{Ni}^{2+}(\text{aq}) + 2\text{e}^-$   
**c** Nickel is the reductant.  
**d** In beaker A the solution will become green as  $\text{Ni}^{2+}$  ions are formed.  
**38 a** In beaker 2:  $\text{C}^{2+}(\text{aq}) + 2\text{e}^- \rightarrow \text{C}(\text{s})$ ;  $\text{B}(\text{s}) \rightarrow \text{B}^{2+}(\text{aq}) + 2\text{e}^-$   
In beaker 3:  $\text{C}^{2+}(\text{aq}) + 2\text{e}^- \rightarrow \text{C}(\text{s})$ ;  $\text{A}(\text{s}) \rightarrow \text{A}^{2+}(\text{aq}) + 2\text{e}^-$   
**b i** B **ii**  $\text{C}^{2+}$   
**c**  $\text{C}^{2+}(\text{aq}) + 2\text{e}^- \rightarrow \text{C}(\text{s})$ ,  $\text{A}^{2+}(\text{aq}) + 2\text{e}^- \rightarrow \text{A}(\text{s})$ ,  $\text{B}^{2+}(\text{aq}) + 2\text{e}^- \rightarrow \text{B}(\text{s})$   
**39 a** From the iron electrode to the lead electrode  
**b** At the lead electrode:  $\text{Pb}^{2+}(\text{aq}) + 2\text{e}^- \rightarrow \text{Pb}(\text{s})$   
At the iron electrode:  $\text{Fe}(\text{s}) \rightarrow \text{Fe}^{2+}(\text{aq}) + 2\text{e}^-$   
**c**  $\text{Fe}(\text{s}) + \text{Pb}^{2+}(\text{aq}) \rightarrow \text{Pb}(\text{s}) + \text{Fe}^{2+}(\text{aq})$  **d** the iron electrode  
**e** the lead electrode **f** towards the iron electrode  
**40 b** At the copper electrode:  $\text{Cu}^{2+}(\text{aq}) + 2\text{e}^- \rightarrow \text{Cu}(\text{s})$   
At the nickel electrode:  $\text{Ni}(\text{s}) \rightarrow \text{Ni}^{2+}(\text{aq}) + 2\text{e}^-$   
**c**  $\text{Ni}(\text{s}) + \text{Cu}^{2+}(\text{aq}) \rightarrow \text{Cu}(\text{s}) + \text{Ni}^{2+}(\text{aq})$   
**41 A**  
**42**  $I = 2.04 \text{ A}$   
**43** 16.0 g Cu and 4.0 g  $\text{O}_2$   
**44 a**  $\text{Li}(\text{l}) + \text{e}^- \rightarrow \text{Li}(\text{l})$  **b**  $2\text{Cl}^-(\text{l}) \rightarrow \text{Cl}_2(\text{g}) + 2\text{e}^-$

## Chapter 8

- 3** floor cleaners, soap, drain cleaners etc.  
**4** change the colour of indicators, can be strong or weak, can be corrosive, distinctive taste  
**5**  $\text{H}_2\text{CO}_3(\text{aq}) + \text{Ca}(\text{OH})_2(\text{aq}) \rightarrow \text{CaCO}_3(\text{s}) + 2\text{H}_2\text{O}(\text{l})$   
**6 a**  $\text{CuO}(\text{aq}) + \text{H}_2\text{SO}_4(\text{aq}) \rightarrow \text{CuSO}_4(\text{aq}) + \text{H}_2\text{O}(\text{l})$   
**b**  $\text{CaS}(\text{aq}) + \text{HNO}_3(\text{aq}) \rightarrow \text{H}_2\text{S}(\text{g}) + \text{Ca}(\text{NO}_3)_2(\text{aq})$   
**c**  $\text{Sn}(\text{s}) + 2\text{HCl}(\text{aq}) \rightarrow \text{SnCl}_2(\text{aq}) + \text{H}_2(\text{g})$   
**d**  $3\text{CaCO}_3(\text{s}) + 2\text{H}_3\text{PO}_4(\text{aq}) \rightarrow \text{Ca}_3(\text{PO}_4)_2(\text{s}) + 3\text{H}_2\text{O}(\text{l}) + 3\text{CO}_2(\text{g})$   
**e**  $\text{Mg}(\text{HCO}_3)_2(\text{aq}) + 2\text{HCl}(\text{aq}) \rightarrow \text{MgCl}_2(\text{aq}) + 2\text{H}_2\text{O}(\text{l}) + 2\text{CO}_2(\text{g})$   
**7 a**  $\text{Pb}(\text{HCO}_3)_2(\text{aq}) + \text{H}_2\text{SO}_4(\text{aq}) \rightarrow \text{PbSO}_4(\text{aq}) + 2\text{H}_2\text{O}(\text{l}) + 2\text{CO}_2(\text{g})$  **b**  $\text{Fe}(\text{OH})_3(\text{s}) + 3\text{HCl}(\text{aq}) \rightarrow \text{FeCl}_3(\text{aq}) + 3\text{H}_2\text{O}(\text{l})$   
**c**  $\text{CaCO}_3(\text{s}) + 2\text{HNO}_3(\text{aq}) \rightarrow \text{Ca}(\text{NO}_3)_2(\text{aq}) + \text{H}_2\text{O}(\text{l}) + \text{CO}_2(\text{g})$   
**8 a** hydrochloric acid  
**b**  $\text{CaCO}_3(\text{s}) + 2\text{HCl}(\text{aq}) \rightarrow \text{CaCl}_2(\text{aq}) + \text{H}_2\text{O}(\text{l}) + \text{CO}_2(\text{g})$ ;  
 $\text{MgCO}_3(\text{s}) + 2\text{HCl}(\text{aq}) \rightarrow \text{MgCl}_2(\text{aq}) + \text{H}_2\text{O}(\text{l}) + \text{CO}_2(\text{g})$ ;  
 $\text{Al}(\text{OH})_3(\text{s}) + 3\text{HCl}(\text{aq}) \rightarrow \text{AlCl}_3(\text{aq}) + 3\text{H}_2\text{O}(\text{l})$   
**11 a**  $\text{H}_2\text{SO}_4(\text{aq})/\text{HSO}_4^-(\text{aq})$ ;  $\text{H}_2\text{O}(\text{l})/\text{H}_3\text{O}^+(\text{aq})$   
**b**  $\text{CH}_3\text{COOH}(\text{aq})/\text{CH}_3\text{COO}^-(\text{aq})$ ;  $\text{OH}^-(\text{aq})/\text{H}_2\text{O}(\text{l})$   
**c**  $\text{CH}_3\text{COOH}(\text{aq})/\text{CH}_3\text{COO}^-(\text{aq})$ ;  $\text{CO}_3^{2-}(\text{aq})/\text{HCO}_3^-(\text{aq})$   
**d**  $\text{HCO}_3^-(\text{aq})/\text{CO}_3^{2-}(\text{aq})$ ;  $\text{OH}^-(\text{aq})/\text{H}_2\text{O}(\text{l})$   
**12 a** triprotic **b**  $\text{H}_3\text{AsO}_4 + \text{H}_2\text{O} \rightarrow \text{H}_2\text{AsO}_4^- + \text{H}_3\text{O}^+$ ;  
 $\text{H}_2\text{AsO}_4^- + \text{H}_2\text{O} \rightarrow \text{HAsO}_4^{2-} + \text{H}_3\text{O}^+$ ;  
 $\text{HAsO}_4^{2-} + \text{H}_2\text{O} \rightarrow \text{AsO}_4^{3-} + \text{H}_3\text{O}^+$   
**c** citric acid, carbonic acid, sulfuric acid  
**15** 7.5 mL **16 a** 2 **b** 11 **c** 5 **d** 7 **e** 6.6 **f** 0.6 **g** 0.3 **h** 7.3



- 17 a  $1 \times 10^{-6}$  M b  $1 \times 10^{-7}$  M c  $1 \times 10^{-13}$  M d  $3 \times 10^{-4}$  M  
 e  $2 \times 10^{-13}$  M f  $4 \times 10^{-6}$  M g  $3 \times 10^{-2}$  M h  $8 \times 10^{-9}$  M  
 18 0.1 19 100 times  
 20 a  $F^-(aq) + H_2O(l) \rightarrow HF(aq) + OH^-(aq)$   
 b  $NH_4^+(aq) + H_2O(l) \rightarrow NH_3(aq) + H_3O^+(aq)$   
 c  $CH_3COO^-(aq) + H_2O(l) \rightarrow CH_3COOH(aq) + OH^-(aq)$   
 d  $H_2PO_4^-(aq) + H_2O(l) \rightarrow HPO_4^{2-}(aq) + H_3O^+(aq)$   
 e  $ClO^-(aq) + H_2O(l) \rightarrow HClO(aq) + OH^-(aq)$   
 f  $[Al(H_2O)_6]^{3+}(aq) + H_2O(l) \rightleftharpoons [Al(OH)(H_2O)_5]^{2+}(aq) + H_3O^+(aq)$   
 21 a acidic b acidic c basic d basic e basic f basic  
 22 C 23 D 26 B 27 A 28 D 29 D 30 B  
 31 a  $H_2SO_4(aq) + Na_2CO_3(aq) \rightarrow Na_2SO_4(aq) + H_2O(l) + CO_2(g)$   
 b 20.8 g c 7.23 kg  
 32 a  $Mg(s) + 2HCl(aq) \rightarrow MgCl_2(aq) + H_2(g)$  b 0.41 g  
 c i Mg, 0.013 mol ii 0.015 g  
 33 C 35 a  $HNO_3$   
 36  $H_3PO_4(aq) + H_2O(l) \rightarrow H_3O^+(aq) + H_2PO_4^-(aq)$ ;  
 $H_2PO_4^-(aq) + H_2O(l) \rightarrow H_3O^+(aq) + HPO_4^{2-}(aq)$ ;  
 $HPO_4^{2-}(aq) + H_2O(l) \rightarrow H_3O^+(aq) + PO_4^{3-}(aq)$   
 37 0.04 mol  
 38 a 0.1 M b 0.044 M c 0.3 M d 0.43 M  
 39 a 1.2 mol b 0.9 mol c 0.115 mol  
 40 0.1 M 41 1.27 42 basic  
 43 a 0.01 M b 0.005 mol 44 a 0.00 b 0.82 c 2.18  
 45 a neutral b basic c acidic d basic e acidic f acidic g basic  
 h neutral i basic

## Chapter 9

- 1 a All substances that contain carbon except the oxides of carbon and carbonates are organic compounds.  
 b A functional group is a group of atoms that influences the properties of compounds forming homologous series.  
 2 aldehyde: ethanal; (alkanal)  $CH_3CHO$ ; alcohol: ethanol; (alkanol)  $CH_3CH_2OH$ ; ketone: butanone; (alkanone)  $CH_3CH_2COCH_3$ ; carboxylic acid: ethanoic acid; (alkanoic acid)  $CH_3COOH$ ; amine: propanamine; (alkanamine)  $CH_3CH_2CH_2NH_2$   
 3 & 4

Compound	Functional group	Name
$C_2H_5OH$	alcohol	ethanol
$HCOOH$	carboxylic acid	methanoic acid
$CH_3CH_2CHO$	aldehyde	propanal
$CH_3COOCH_3$	ester	methyl ethanoate
$CH_3COCH_3$	ketone	propanone
$CH_2=CH_2$	alkene	ethene

- 6 a i combustion ii addition iii substitution iv addition  
 b i a  $2C_4H_{10} + 13O_2 \rightarrow 8CO_2(g) + 10H_2O$   
 ii  $CH_3CH=CH_2 + Cl_2 \rightarrow CH_3CHClCH_2Cl$   
 iii  $CH_4 + Cl_2 \rightarrow CH_3Cl + HCl$   
 iv  $CH_3CH_2CH=CH_2 + H_2 \rightarrow CH_3CH_2CH_2CH_3$   
 7  $C_2H_5$   
 8 a  $CH_2O$  b  $C_6H_{12}O_6$

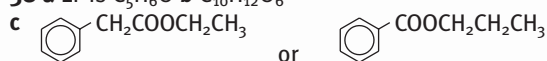
13

Alcohol		
Name	Structure	Type of alcohol
ethanol	$CH_3CH_2OH$	primary
2-propanol	$CH_3CHOHCH_3$	secondary
1-pentanol	$CH_3(CH_2)_4OH$	primary
3-methyl-3-hexanol	$CH_3CH_2C(CH_3)OHCH_2CH_2CH_3$	tertiary

- 14 ethanol, 1-pentanol, 2-propanol, 3-methyl-3-hexanol  
 15 alkanols and carboxylic acids, formed by the oxidation of 1° alcohols; ketones formed by the oxidation of 2° alcohols  
 16 Methanol cannot be oxidised to a ketone because it is only a primary alcohol and the simplest ketone (propanone) requires 3 carbons.  
 17 a  $2MnO_4^- + 6H^+ + 5CH_3OH \rightarrow 2Mn^{2+} + 8H_2O + 5HCHO$   
 b  $4MnO_4^- + 12H^+ + 5CH_3CH_2OH \rightarrow 4Mn^{2+} + 5CH_3 + COOH + 11H_2O$   
 c  $3CH_3CHOHCH_2CH_2CH_3 + Cr_2O_7^{2-} + 8H^+ \rightarrow 2Cr^{3+} + 7H_2O + 3CH_3COCH_2CH_2CH_3$   
 18 2-Butanol can be prepared by the oxidation of 2-butanol.  
 $3CH_3CHOHCH_2CH_3 + Cr_2O_7^{2-} + 8H^+ \rightarrow 2Cr^{3+} + 7H_2O + 3CH_3COCH_2CH_3$   
 21 a  $HCOOH + NaOH \rightarrow HCOONa + H_2O$   
 b  $2HCOOH(aq) + Mg(s) \rightarrow Mg(HCOO)_2(aq) + H_2(g)$   
 22 a esterification (reaction) b esters (product)  
 c  $RCOOH + R'OH \rightarrow RCOOR' + H_2O$   
 23 a carboxylic acid, propanoic acid b carboxylic acid, butanoic acid c alcohol, hexanol d ester, ethyl hexanoate  
 24 a methanamine, primary amine b dimethylamine, secondary amine c ethylmethylamine, secondary amine d aniline or benzylamine, primary amine  
 26  $CH_3CH_2CH_2CH_2Cl + NH_3 \rightarrow CH_3CH_2CH_2CH_2NH_2 + HCl$   
 27 Amphoteric means able to react as an acid and as a base.  
 29 A peptide bond is the bond between two amino acids.  
 30 B  
 31 B  
 32 a propyne (yne—an alkyne)  $HC\equiv CCH_3$   
 butanoic acid (carboxylic acid)  $CH_3CH_2CH_2COOH$   
 pentanone (ketone)  $CH_3COCH_2CH_2CH_3$   
 ethanol (alcohol)  $CH_3CH_2OH$   
 propanamine (amine)  $CH_3CH_2CH_2NH_2$   
 ethanal (aldehyde or alkanal)  $CH_3CHO$   
 b i propanal ii propene iii phenol or benzyl alcohol  
 iv dichloromethane v pentanoic acid vi 2-butyne  
 vii 3-hexanone viii 3-aminopropanoic acid  
 33 b 4; polar; soluble  
 34 a  $2C_4H_{10} + 13O_2 \rightarrow 8CO_2 + 10H_2O$   
 b  $2C_5H_{10} + 15O_2 \rightarrow 10CO_2 + 10H_2O$   
 c  $C_7H_{12} + 10O_2 \rightarrow 7CO_2 + 6H_2O$   
 35 A substitution reaction involves the replacement of an atom (or group of atoms) by another atom or group of atoms. An addition reaction involves the adding of atoms to an unsaturated organic compound.  
 36 a  $CH_4 + 4Cl_2 \rightarrow CCl_4 + 4HCl$   
 b  $CH_2=CH_2 + Br_2 \rightarrow CH_2BrCH_2Br$  (1,2-dibromoethane)  
 c  $HC\equiv CH + 2H_2 \rightarrow CH_3CH_3$   
 37 EF is CH



38 a EF is C<sub>5</sub>H<sub>6</sub>O b C<sub>10</sub>H<sub>12</sub>O<sub>6</sub>



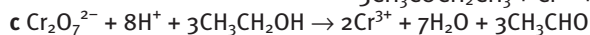
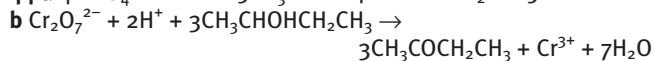
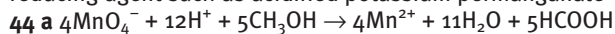
41

Name of alcohol	Formula of alcohol	Type of alcohol
ethanol	CH <sub>3</sub> CH <sub>2</sub> OH	primary
2-propanol	CH <sub>3</sub> CHOHCH <sub>3</sub>	secondary
2-methyl-2-butanol (or group of atoms) by another atom or group of atoms	(CH <sub>3</sub> ) <sub>2</sub> COHCH <sub>2</sub> CH <sub>3</sub>	tertiary
butanol	CH <sub>3</sub> CH <sub>2</sub> CH <sub>2</sub> CH <sub>2</sub> OH	primary
2-3-hexanediol	CH <sub>3</sub> CHOHCHOHCH <sub>2</sub> CH <sub>2</sub> CH <sub>3</sub>	secondary

43 a aldehyde: oxidation of a primary alcohol

b ketone: oxidation of a secondary alcohol

c carboxylic acid: oxidation of a primary alcohol using a strong reducing agent such as acidified potassium permanganate



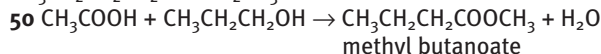
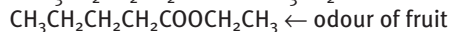
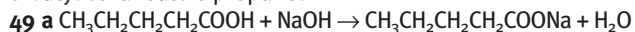
45

Name of compound	Formula of compound	Type of compound
methanol	CH <sub>3</sub> OH	alcohol
ethanal	CH <sub>3</sub> CHO	aldehyde
2-butanone	CH <sub>3</sub> COCH <sub>2</sub> CH <sub>3</sub>	ketone
pentanoic acid	CH <sub>3</sub> CH <sub>2</sub> CH <sub>2</sub> CH <sub>2</sub> COOH	carboxylic acid
butanal	CH <sub>3</sub> CH <sub>2</sub> CH <sub>2</sub> CHO	aldehyde

47 A

48 a butanoic acid b hexanoic acid c methyl pentanoate

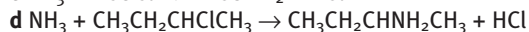
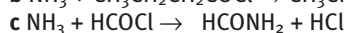
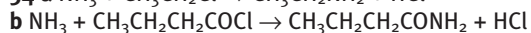
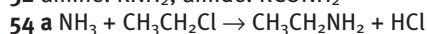
d butyl ethanoate e propanol



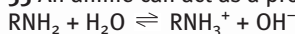
51

	Alcohol	Acid
a	ethyl methanoate	ethanol methanoic acid
b	butyl ethanoate	butanol ethanoic acid
c	CH <sub>3</sub> CH <sub>2</sub> CH <sub>2</sub> CH <sub>2</sub> COOCH <sub>2</sub> CH <sub>2</sub> CH <sub>3</sub>	propanol pentanoic acid
d	CH <sub>3</sub> CH <sub>2</sub> CH <sub>2</sub> COOCH <sub>2</sub> CH <sub>3</sub>	ethanol butanoic acid

52 amine: RNH<sub>2</sub>; amide: RCONH<sub>2</sub>



55 An amine can act as a proton acceptor (i.e. as a base).



57 a A b B

## Chapter 10

4 486 000 g mol<sup>-1</sup> 5 HDPE

8 polypropene

10 a methyl pentanoate + water b ethyl ethanoate + water

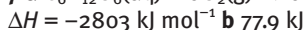
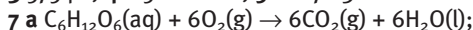
c butyl propanoate + water

11 water 21 A 22 D 23 B 25 ethene

## Chapter 11

1 a exothermic b endothermic c endothermic d exothermic

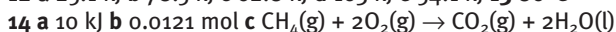
3 5754 kJ 4  $2.52 \times 10^4$  kJ 5 C 6 7.83 L



9 671 kJ

10 a -494 kJ; exothermic b 212 kJ; endothermic c -1259 kJ; exothermic

12 a 25.1 kJ b 78.5 kJ c 62.8 kJ d 103 kJ e 54.1 kJ 13 80°C



16 water 17 a 398 kJ mol<sup>-1</sup>

18 a CO<sub>2</sub>(g) b H<sub>2</sub>O(l) c H<sub>2</sub>O at 80°C d NaCl(aq)

19 a increase b decrease c decrease d decrease

20 a non-spontaneous, entropy decreases, enthalpy increases

b spontaneous, entropy increases, enthalpy decreases

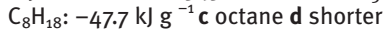
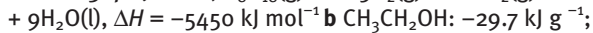
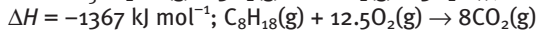
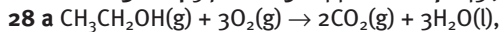
c depends on factor of greatest influence, entropy decreases,

enthalpy increases d depends on factor of greatest influence,

entropy increases, enthalpy increases e depends on factor of

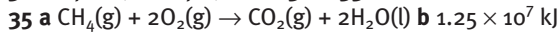
greatest influence, entropy increases, enthalpy increases

21 C 22 A 23 A 24 5.7 mol 25 1.44 L 26 D 27 143 J



29 a -118 kJ b -109 kJ 30 a 33.8 kJ b 157 kJ c 60.0 kJ d 49.3 kJ

31 a 0.711 kJ b 18.7 kJ mol<sup>-1</sup> 32 C 33 C



c  $3.3 \times 10^5 \text{ L}$

36 a 18.07°C 37 357 g

38 a decreases b decreases c increases d increases

e decreases f increases

39 a decrease b increase c increase d small increase or decrease

40 a depends on factor of greatest influence

b spontaneous (a known reaction)—entropy decreases but enthalpy decreases as well

c depends on factor of greatest influence

d spontaneous—entropy increases and enthalpy decreases

## Chapter 12

1 a qualitative b quantitative c quantitative d quantitative

2 a qualitative 5 copper 6 a chalk b water

9 A: 0.58, B: 0.78

10 a iron b melting point, conductivity, chemical reactivity



- 13 2-naphthol or benzoic acid 17 yes 18 1%  
 20 a qualitative b quantitative c qualitative d quantitative  
 21 b 285 mg c 24g 22 2.7 serves 23 c barium  
 26 red, 0.58; blue 0.83  
 27 a 3.2 cm b 15 cm 28 magnesium  
 29 a lead 30 a citric acid b group 3  
 32 b i 1000 samples c yes  
 33 a i qualitative ii is quantitative  
 34 yes 35 a 330 g b i 10.2 g ii 191g c 4.95 µg

## Chapter 13

- 2 8.44 g 3 a 69.9% b 84.8% c 26.2% d 51.2%  
 4 a C 93.8%; H 6.2% b C 40%; H 6.7%; O 53.3% c Al 12.7%; N 19.7%; O 67.6% d N 46.7%; H 6.7%; O 26.7%; C 19.9%  
 e H 1%; O 63.7%; Cl 35.3% f C 60.0%; H 4.4%; O 35.6%  
 5 0.12 g 6 a C<sub>6</sub>H<sub>6</sub> b H<sub>2</sub>O<sub>2</sub> c C<sub>3</sub>H<sub>6</sub>O<sub>3</sub> d NO<sub>2</sub> e C<sub>11</sub>H<sub>22</sub>  
 7 a HCl b CO c MgO d CH<sub>4</sub>  
 8 empirical formula is CH<sub>3</sub>O, molecular formula is C<sub>2</sub>H<sub>6</sub>O<sub>2</sub>  
 9 a P<sub>2</sub>O<sub>5</sub> b P<sub>4</sub>O<sub>10</sub>  
 10 12.8 g 11 CuSO<sub>4</sub>·4H<sub>2</sub>O 12 CaSO<sub>4</sub>·2H<sub>2</sub>O  
 13 a i KI ii <7 because of H<sub>2</sub>CO<sub>3</sub> produced iii methyl orange  
 b i Na<sub>2</sub>C<sub>2</sub>O<sub>4</sub> ii >7 iii phenolphthalein c i Na<sub>2</sub>S ii >7  
 iii phenolphthalein  
 14 The indicator would change colour when the volume of acid added is less than that required for equivalence.  
 16 a 2HCl(aq) + Na<sub>2</sub>CO<sub>3</sub>(aq) → 2NaCl(aq) + H<sub>2</sub>O(l) + CO<sub>2</sub>(g)  
 b 0.573 M  
 17 0.1029 M  
 18 a 0.002 19 mol b 0.002 19 mol c 0.109 M d 1.09 M  
 19 a 0.009 80 mol b 0.005 55 mol c 0.005 55 mol  
 d 0.004 25 mol e 0.002 13 mol f 87.6%  
 20 a 0.250 g b 19.1% c fillers, binders, sweeteners, flavours, colourings  
 21 a NaCl(aq) + AgNO<sub>3</sub>(aq) → AgCl(s) + NaNO<sub>3</sub>(aq) or Cl<sup>-</sup>(aq) + Ag<sup>+</sup>(aq) → AgCl(s) c IV, II, V, I, VI, III d i too high ii too high  
 22 a 0.455 g b 0.797 g  
 23 a Al 52.9%; O 47.1% b Cu 65.1%; O 32.8%; H 2.1%  
 c Mg 12.0%; Cl 34.9%; H 5.9%; O 47.2% d Fe 27.9%; S 24.1%; O 48.0%  
 24 a 2.53 × 10<sup>-3</sup> mol b 0.141 g c 88.1% 25 a 18.3% 26 14.3%  
 27 a 26.9% c higher  
 28 a C<sub>4</sub>H<sub>10</sub> b P<sub>4</sub>O<sub>10</sub> c C<sub>6</sub>H<sub>12</sub>O<sub>6</sub> d H<sub>2</sub>S<sub>2</sub>O<sub>7</sub> e C<sub>4</sub>H<sub>8</sub>O<sub>2</sub> f C<sub>6</sub>H<sub>4</sub>N<sub>2</sub>O<sub>4</sub>  
 29 empirical formula is C<sub>4</sub>H<sub>5</sub>, molecular formula is C<sub>8</sub>H<sub>10</sub>  
 30 31.0 g mol<sup>-1</sup>  
 31 a D, F, E, A, C, B c calcium  
 32 C<sub>8</sub>H<sub>8</sub>O<sub>3</sub> 33 a CH<sub>2</sub>O b C<sub>2</sub>H<sub>4</sub>O<sub>2</sub> 35 A  
 36 a 0.9 g b 2.6% c > 100°C f no 37 48.80 mL  
 39 The salt produced (sodium ethanoate) is a basic salt. The volume would be greater.  
 40 a sodium carbonate solution b 8 and 4 c phenolphthalein  
 d NaHCO<sub>3</sub> + HCl → NaCl + CO<sub>2</sub> + H<sub>2</sub>O  
 41 0.213 g 42 b 0.620%  
 43 a yellow to pink b 2HCl(aq) + MgCO<sub>3</sub>(aq) → MgCl<sub>2</sub>(aq) + H<sub>2</sub>O(l) + CO<sub>2</sub>(g) c 0.0278 mol d 90.0% e binder and flavouring  
 44 a CH<sub>3</sub>COOH(aq) + NaOH(aq) → CH<sub>3</sub>COONa(aq) + H<sub>2</sub>O(l)  
 b 0.937 M c 56.2 g L<sup>-1</sup>

- 45 a H<sub>2</sub>SO<sub>4</sub>(aq) + M<sub>2</sub>CO<sub>3</sub>(aq) → M<sub>2</sub>SO<sub>4</sub>(aq) + H<sub>2</sub>O(l) + CO<sub>2</sub>(g)  
 b 0.001 62 mol c 0.001 62 mol d 0.0203 mol e 138 g mol<sup>-1</sup>  
 f potassium  
 46 4.4 L 47 c 0.117 M d i higher ii higher  
 48 b OH<sup>-</sup>(aq) + H<sub>3</sub>O<sup>+</sup>(aq) → 2H<sub>2</sub>O(l) c 0.001 26 mol d 0.126 mol  
 e 0.0686 mol f 0.0191 mol, 1.49 g g & h 20 mL pipette, undiluted antacid; 200 mL volumetric flask, water; 20 mL pipette, diluted antacid; burette, hydrochloric acid; conical flask, water  
 49 a 0.001 13 mol b 0.001 13 mol c 0.000 914 mol d 0.0114 mol  
 e 12.9%  
 50 a 2HCl(aq) + CaCO<sub>3</sub>(s) → CaCl<sub>2</sub>(aq) + H<sub>2</sub>O(l) + CO<sub>2</sub>(g); HCl(aq) + NaOH(aq) → NaCl(aq) + H<sub>2</sub>O(l) b 0.001 091 mol  
 c 0.019 75 mol d 0.018 66 mol e 0.933 g f 88.8%  
 51 a 5Fe<sup>2+</sup>(aq) + MnO<sub>4</sub><sup>-</sup>(aq) + 8H<sup>+</sup>(aq) → 5Fe<sup>3+</sup>(aq) + Mn<sup>2+</sup>(aq) + 4H<sub>2</sub>O(aq) b 0.0030 35 mol c 84.7%  
 52 a i 0.000 460 mol ii 0.000 690 mol iii 0.008 62 mol  
 iv 0.396 g v 3.60% b no  
 53 a Fe<sup>2+</sup>(aq) → Fe<sup>3+</sup>(aq) + e<sup>-</sup> b MnO<sub>4</sub><sup>-</sup>(aq) + 8H<sup>+</sup>(aq) + 5e<sup>-</sup> → Mn<sup>2+</sup>(aq) + 4H<sub>2</sub>O(l) c 5Fe<sup>2+</sup>(aq) + MnO<sub>4</sub><sup>-</sup>(aq) + 8H<sup>+</sup>(aq) → 5Fe<sup>3+</sup>(aq) + Mn<sup>2+</sup>(aq) + 4H<sub>2</sub>O(l) d 0.001 30 mol e 0.0162 mol  
 f 0.246 g  
 54 a 0.009 41 mol b 0.009 41 mol c 3.5%  
 55 a 1.68 g 56 b 1.84 × 10<sup>-3</sup> mol c no effect d no effect

## Chapter 14

- 4 b 2.57 ppm c 25.7 ppm d 6.4 × 10<sup>-3</sup> g e 36%  
 5 a 0.080 M solution b 0.30 M solution  
 7 a 32 mg L<sup>-1</sup> b 3.2%  
 12 a 2 peaks b 4 peaks  
 14 stationary phase, mobile phase and separation of components  
 15 paper chromatography: A, D; column chromatography: A, B, D; thin layer chromatography: A, D; gas-liquid chromatography: C, D, E, F; high performance liquid chromatography: B, D, E  
 17 D 18 violet line on the far right-hand side  
 19 B 20 A  
 21 a 7.2 µg mL<sup>-1</sup> b 1.4 × 10<sup>-3</sup> g c 700 g Cu, no d \$1.10  
 22 b 16 mg c 0.32% w/w 23 C  
 24 a i copper hexaaqua ion, Cu(H<sub>2</sub>O)<sub>6</sub><sup>2+</sup> ii Cu atoms  
 b colorimetry c i white light is passed through a filter  
 ii a hollow cathode lamp with a cathode of the required element  
 25 B 26 9.8 ppm  
 30 a OH group b CH bonds on the benzene ring  
 31 tartaric acid, 3 signals; succinic acid, 2 signals; citric acid, 3 signals  
 33 A 34 C 35 C 36 A 37 D 38 A 39 A 40 b 4  
 42 a A, hexane; B, heptane; C, octane; D, decane  
 43 a no b no  
 44 a 8.0 µg mL<sup>-1</sup> b 8.0 mg nitroglycerine c 1.6% w/w  
 45 c 13 ppm d no e 92 mL



## Chapter 15

- 2 a** increased reaction rate **b** decreased reaction rate  
**c** increased reaction rate **d** increased reaction rate  
**e** increased reaction rate  
**7 a** exothermic A and B, endothermic C **b** C **c** B **d** C  
**10 a** first step **b** F(g) **c**  $2\text{NO}_2(\text{g}) + \text{F}_2(\text{g}) \rightarrow 2\text{NO}_2\text{F}(\text{g}) + \text{energy}$   
**11 a** 3 **b** 2 **c** false **d** first step  
**13** rate =  $k[\text{BrO}_3^-]^1[\text{Br}^-]^1[\text{H}^+]^2$ , overall fourth order  
**14 a** second order **b** second order **c**  $k = 6.0 \times 10^{-4}$   
**15 a** first order **b** first order **c** rate =  $k[\text{NO}][\text{O}_3]$  **d**  $5.0 \times 10^{-4}$   
**16** D **17** A **19** endothermic  
**20** graph A:  $40^\circ\text{C}$ ; graph B:  $60^\circ\text{C}$  **27 b**  $2\text{Fe}(\text{s}) + \text{O}_2(\text{g}) \rightarrow 2\text{FeO}(\text{s})$ ;  
 $4\text{Fe}(\text{s}) + 3\text{O}_2(\text{g}) \rightarrow 2\text{Fe}_2\text{O}_3(\text{s})$  **c** no **d** exothermic **e** high surface area of iron pellets, high temperature caused by trapped heat that was unable to escape rapidly  
**28 a** Cl,  $\text{CCl}_3$  **b**  $\text{Cl}_2(\text{g}) + \text{CHCl}_3(\text{g}) \rightarrow \text{CCl}_4(\text{g}) + \text{HCl}(\text{g})$   
**29**  $\text{I}_2(\text{s}) + \text{H}_2\text{O}_2(\text{aq}) \rightarrow 2\text{I}^-(\text{aq}) + 2\text{H}^+(\text{aq}) + \text{O}_2(\text{g})$ ;  
 $2\text{I}^-(\text{aq}) + \text{H}_2\text{O}_2(\text{aq}) + 2\text{H}^+(\text{aq}) \rightarrow \text{I}_2(\text{s}) + 2\text{H}_2\text{O}(\text{l})$   
**30 a** second order, NO; second order overall **b** first order, C and  $\text{O}_2$ ; second order overall **c** first order, Cl; second order,  $\text{H}_2$ ; third order overall **d** first order,  $\text{Ca}^{2+}$ ,  $\text{OH}^-$  and  $\text{PO}_4^{3-}$ ; third order overall  
**31 a** second order **b** second order **c** fourth order  
**d** rate =  $k[\text{O}_2]^2[\text{SO}_2]^2$

## Chapter 16

- 1 c** photosynthesis  
**2 a**  $6\text{CO}_2(\text{g}) + 6\text{H}_2\text{O}(\text{l}) \rightarrow \text{C}_6\text{H}_{12}\text{O}_6(\text{aq}) + 6\text{O}_2(\text{g})$  **b**  $5.4 \times 10^{25}$  g  
**3 b** no  
**4 b** condensation **c** hydroxy functional groups  
**5 b**  $\text{H}_2\text{NCH}(\text{CH}_2\text{OH})\text{COOH} + \text{H}_2\text{NCH}(\text{CH}_2\text{SH})\text{COOH} \rightarrow \text{H}_2\text{NCH}(\text{CH}_2\text{OH})\text{CONHCH}(\text{CH}_2\text{SH})\text{COOH} + \text{H}_2\text{O}$  **c** condensation  
**6 a**  $\text{H}_2\text{NCHCH}_3\text{CONHCH}_2\text{COOH}$ ,  $\text{H}_2\text{NCH}_2\text{CONHCHCH}_3\text{COOH}$   
**b** 6 (using each amino acid once in each peptide)  
**c** very large numbers  
**7 b**  $\text{H}_2\text{NCHCH}_3\text{COOH}$ ,  $\text{H}_2\text{NCH}(\text{CH}_2\text{SH})\text{COOH}$ ,  $\text{H}_2\text{NCH}_2\text{COOH}$ ,  $\text{H}_2\text{NCH}(\text{CH}_2\text{OH})\text{COOH}$  **c** stomach and small intestine  
**9 a** combination of primary structure, secondary structure and tertiary structure **b** shape may change, rate slows down  
**c** protein denatures, changes shape and coagulates  
**17 b** A: photosynthesis; B: respiration; C: combustion  
**c** **i**  $6\text{CO}_2(\text{g}) + 6\text{H}_2\text{O}(\text{l}) \rightarrow \text{C}_6\text{H}_{12}\text{O}_6(\text{aq}) + 6\text{O}_2(\text{g})$   
**ii**  $\text{C}_6\text{H}_{12}\text{O}_6(\text{aq}) + 6\text{O}_2(\text{g}) \rightarrow 6\text{CO}_2(\text{g}) + 6\text{H}_2\text{O}(\text{l})$   
**iii**  $\text{CH}_4(\text{g}) + 2\text{O}_2(\text{g}) \rightarrow \text{CO}_2(\text{g}) + 2\text{H}_2\text{O}(\text{l})$   
**19 a** 1.2%  
**21** D **22** B  
**23 a** 15.6 kJ **b** 219 mL **c**  $7.7 \times 10^2$  g **d**  $5.8 \times 10^2$  L  
**24 a**  $\text{C}_6\text{H}_{12}\text{O}_6(\text{aq}) + 6\text{O}_2(\text{g}) \rightarrow 6\text{CO}_2(\text{g}) + 6\text{H}_2\text{O}(\text{l})$ ;  
 $\Delta H = -2803$  kJ mol<sup>-1</sup> **b** 77.9 kJ  
**25** A **31** D **32** D **33** A

## Chapter 17

- 1 a** increase; increase; reversible **b** decrease; decrease; reversible **c** increase; decrease; non-spontaneous  
**d** decrease; decrease; reversible **e** decrease; increase; spontaneous **f** decrease; decrease; reversible  
**g** decrease; increase; spontaneous  
**4 a** more intense orange **b** shift to the left; less orange and more yellow  
**5 a** exothermic **b** product **c** Joe  
**7 a**  $\text{PbI}_2(\text{s}) \rightarrow \text{Pb}^{2+}(\text{aq}) + 2\text{I}^-(\text{aq})$  **b** no effect  
**8 a**  $K = [\text{H}_2] \times [\text{I}_2] / [\text{HI}]^2$  **b**  $K = [\text{NO}_2]^2 / [\text{N}_2\text{O}_4]$   
**c**  $K = [\text{FeSCN}^{2+}] / [\text{Fe}^{3+}] \times [\text{SCN}^-]$  **d**  $K = [\text{Pb}^{2+}] [\text{I}^-]^2$   
**10**  $K = 4.36$  **11** 0.26M  
**12 a**  $[\text{N}_2]$ ,  $[\text{O}_2]$  1.80 M,  $[\text{NO}]$  0.40 M **b** 1.86 M, 0.86 M, 0.28 M  
**c** 4.78 M, 0.78 M, 0.44 M **d** 0.90 M, 0.90 M, 0.20 M  
**e** 2.25 M, 2.25 M, 0.50 M  
**13**  $4.2 \times 10^{-3}$  M **14**  $1.5 \times 10^{-5}$  M **15**  $6.0 \times 10^{-3}$  M  
**17**  $\text{Ca}^{2+}$ ,  $6.9 \times 10^{-3}$  M;  $\text{OH}^-$   $1.4 \times 10^{-2}$  M  
**18 a**  $5.7 \times 10^{-13}$  g **b**  $1.4 \times 10^9$  **19** no **20** yes  
**21**  $4 \times 10^{-9}$  mol L<sup>-1</sup> **22**  $1.3 \times 10^{-3}$  mol L<sup>-1</sup> **23**  $4.0 \times 10^{-12}$  M  
**24**  $5.8 \times 10^{-3}$  M,  $1.7 \times 10^{-12}$  M **25**  $1.1 \times 10^{-11}$  M  
**26** 0.70 **27** 4.5 **28**  $1.6 \times 10^{-6}$  **29**  $6.3 \times 10^{-10}$ ,  $1.6 \times 10^{-6}$  M  
**30**  $\text{pH}(\text{HCl}) = -0.30$ ,  $\text{pH}(\text{CHOOH}) = 1.7$ ,  $\text{pH}(\text{HClO}) = 3.6$   
**31** B **33** C **34** A **35** C **36** A  
**37** decrease, decrease, no change, decrease, decrease, decrease, no change, no change  
**38 a**  $\text{I}_2(\text{g})$  added **b** temperature increase  
**40** D **41** C **42**  $K = [\text{C}]^c [\text{D}]^d / [\text{A}]^a [\text{B}]^b$   
**43 b**  $K = [\text{NO}_2]^2 / [\text{N}_2\text{O}_4]$  **d** 0.2 M  
**44 a** 110 **b** no,  $\text{N}_2\text{O}_4$   
**45 a**  $K = [\text{SO}_3]^2 / [\text{O}_2] \times [\text{SO}_2]^2$  **b**  $3.61 \times 10^{-3}$  M  
**46 a** x mol, 2x mol **b**  $2.00 - x$  M;  $2.00 - x$  M, 2x M **c** 3.15 mol  
**47 a**  $(\text{CH}_3)_2\text{NH}(\text{aq}) + \text{H}_2\text{O}(\text{l}) \rightarrow (\text{CH}_3)_2\text{NH}_2^+(\text{aq}) + \text{OH}^-(\text{aq})$   
**b**  $K_b = [(\text{CH}_3)_2\text{NH}_2^+] \times [\text{OH}^-] / [(\text{CH}_3)_2\text{NH}]$   
**48 b**  $1.14 \times 10^{-3}$  M **c** 2.94 **d** 1.14%  
**49 a**  $1.18 \times 10^{-3}$  M;  $5.5 \times 10^{-3}$  M;  $5.5 \times 10^{-3}$  M **b**  $3.75 \times 10^{-3}$  M;  $1.50 \times 10^{-2}$  M;  $6.25 \times 10^{-3}$  M  
**50** B **52** B **53** C **54** C **55** A **56** AgOH







- A–B polymers 417  
absolute temperature scale 314–15  
absolute zero 314  
acetic acid *see* ethanoic acid  
acetic anhydride 165  
acetylsalicylic acid 165  
acid–base titrations 468–9  
  choice of indicators 469–70  
  strong acid vs strong base 470–1  
  strong acid vs weak base 471  
  strong base vs weak acid 471–2  
  techniques 475–6  
  titration curves 469, 470–1, 472, 473–4  
  weak acid vs weak base 472–3  
acid rain 23, 123, 204  
acidic salts 379  
acids 366  
  Arrhenius 370–1  
  Brønsted–Lowry 371, 470  
  properties 367  
  reactions involving 368–9  
  strength 373–4  
acrylic 414, 415  
acrylonitrile 415  
actinides 227  
activation energy 514  
actual yield 280  
addition polymerisation 414–15  
addition polymers 414–15  
addition reactions 39, 185, 187  
adipoyl chloride 417–18  
adsorption 444, 501  
air pressure 5  
  measurement 308–9  
  units of 309–10  
alchemists 4  
alcohol content of alcoholic beverages 149–50, 395  
alcohol derivatives 398–9  
alcohols 254, 387, 395–6  
  boiling temperatures 254  
  as fuel 125–6  
  oxidation of 398–400  
  primary 395, 398  
  reaction with carboxylic acids 401–2, 416–17  
  secondary 395, 398  
  systematic naming 37–8  
  tertiary 396, 398  
aldehydes 387, 398  
  properties 400  
alkali metals 228  
alkaline earth metals 228  
alkalis 366  
alkanals 387, 398  
alkanamides 388  
alkanamines 387  
alkanes 247–8  
  boiling temperatures 252  
  systematic naming 250–1  
alkanoic acids 254, 387, 398  
alkanols 254, 387  
alkanones 387, 398  
alkenes 248, 387  
  boiling temperatures 252, 254  
  systematic naming 251  
alkoxyalkanes 388  
alkyl alkanoates 388  
alkylbenzene sulfonates 89  
alkynes 250, 387  
  systematic naming 251  
alloys 28, 30  
  features 29  
  interstitial 29–30  
  preparation of solder 31  
  substitutional 29  
aluminium  
  anodising 113–14  
  refining 99–100  
amide bonds 417  
amides 388, 404  
amines 387, 403–4, 417  
amino acids 190, 191, 404–5, 535–7  
ammonia 370, 371, 375, 548  
  decomposition 425–6  
  in household cleaner 157  
  manufacture (Haber process) 196–7, 562  
  production 426  
ammonia derivatives 403–5  
amphiprotic substances 372  
anaerobic respiration 145  
ancient civilisations 3  
anhydrous substances 463  
anions, names and formulae 230  
annealing 32  
anode 352  
anodising aluminium 113–14  
antacids 54–5  
  comparison 159  
  rate of reaction 522  
Aristotle 3  
Arrhenius acids and bases 370–1  
artificial atmospheres 25–6  
artificial flavourings 36–7  
ascorbic acid, in vitamin C tablets 159  
aspirin 54  
  development 164–5  
  in pain relievers 157  
atmospheres  
  artificial 25–6  
  Earth 20–3, 42–8  
  Mars 25  
  Venus 24  
atmospheric gases 42, 45–8, 123, 204, 549  
atomic absorption spectrometer 490  
atomic absorption spectroscopy 489–91  
atomic emission spectroscopy 488–9  
atomic mass 6, 213–14  
atomic models 7–8, 209–10  
atomic number 212  
atomic structure 209–11  
atomic theory 6, 7–9  
atomic weight 6, 7  
atoms 5–6  
  bonding 228–46  
  electron configuration 215–17  
  electronic structure 215–20  
  energy levels 219  
  Avogadro's hypothesis 321  
Avogadro's number 269  
  determination 271  
back titrations 476–8  
Baghdad battery 130  
Bakelite 410  
balancing chemical equations 273  
barometer 308  
bases 366, 367  
  Arrhenius 370–1  
  Brønsted–Lowry 371, 471  
  properties 367  
  strength 375  
basic salts 379  
batteries 129–30, 349  
bauxite 100  
benzene 253  
Berzelius, Jöns Jacob 6  
Big Bang 11  
binding energy 14  
  elements heavier than iron 14  
  lighter elements 14  
biological oxygen demand (BOD) 61  
birth defects 165–6  
black hole 16  
bleach 54  
blocks (periodic table) 27  
Bohr, Niels, model of the atom 8  
bomb calorimeter 137  
bond energies 427–8  
bonding 228  
  classifying matter by 256–7  
  covalent 233–42  
  ionic 229–32  
  metallic 244–6  
bonding pair 234  
bottled water, chemical analysis 52–3  
Boyle, Robert 5  
Boyle's Law 311–13  
breathing under water 25, 48–9  
bromine  
  applications 106  
  extraction from sea water 105–7, 108  
bromocresol green 380  
Brønsted–Lowry theory 371–2, 470, 471  
bronze 3, 29  
buckyballs 82  
buffers 379, 380  
but-1-ene 251  
but-2-ene 251  
butane 251



- calcium carbonate 206  
 calorimetry 137, 430–1  
 carbohydrates 189–90, 538–40  
   energy content 140  
   structure 543  
 carbon cycle 546–7  
 carbon dioxide  
   in the atmosphere 47–8, 123  
   and greenhouse effect 23  
   in Mars atmosphere 25  
   in ocean waters 205  
   polar bonds 238  
   solubility 205  
 carbon nanotubes 82–3  
 carbon steel 29, 30  
 carbonate ion 55  
 carbonyl functional group 387  
 carboxyl functional group 254, 401  
 carboxylic acids 254–5, 387, 398  
   properties 400  
   reactions with alcohols 401–2,  
     416–17  
   reactions with hydroxides 401  
   reactions with metals 401  
   systematic naming 38  
 catalysts  
   affect on rate of reaction 516–19,  
     521  
   heterogeneous 519  
   homogeneous 517  
 catalytic cracking 185  
 cathode 352  
 cations, names and formulae 230  
 cells 129–30  
 cellular respiration 133  
 celluloid 411  
 cellulose 412  
 charge cloud diagrams 233  
 Charles' Law 314, 315  
 chemical equations 272  
   balancing 273  
 chemical industry 178–81  
   ammonia manufacture 196–7, 562  
   ethene manufacture 184–7  
   sulfuric acid manufacture 181–3  
 chemical plant 179–80  
   operation 180–1  
 chemical properties 226  
   and periodic table 227–8  
   used in qualitative analysis 450–1  
 chemical reactions 272–4  
   and cell emf 354–5  
   observing 274  
   percent yield 280–1  
   stoichiometry 275–9  
   types of 328–32, 333–4  
 chemical shift 500  
 chemistry  
   in ancient times 2–3  
   in the supermarket 52–5  
 chloride ions 231  
   in water, quantitative analysis 65  
 chlorine, in household bleach 160  
 chlorine molecule 233  
   different representations 235  
 chlorophyll 532  
 chromatograms 444–5  
 chromatography 155, 172–3, 443–7,  
   501–2  
   column 502  
   gas–liquid 503–4  
   high performance liquid 502–3  
   paper 444–7, 502  
   thin-layer 502  
 citric acid 55  
 cleaning agents 85  
 coenzymes 536, 540  
 cold stabilisation 150  
 collision theory 514–15  
 colorimeter 492  
 colorimetry 160–1, 491–3  
 colour mixture separation 155  
 column chromatography 502  
 combination reactions 328–9  
 combined gas equation 317–18  
 combustion 123–4, 125, 133, 340  
   methane 124, 424–5  
   octane 133, 557  
 combustion reactions 339, 391–2  
 common ion effect 575–6  
 composites 81  
 concentrated acids or bases 373  
 concentration  
   affect on equilibrium 559–61  
   affect on rate of reaction 515–16,  
     526–7  
   dilutions 297–8  
   molarity 296–7  
   and rate laws 527–8  
   and strength 373–5  
   units of 54, 155  
 concentration–time graphs 556  
 condensation polymerisation 416–18  
 condensation polymers 416  
 condensation reactions 536, 540, 545  
 conjugate acid 371  
 conjugate acid–base pair 371, 379  
 conjugate base 371  
 consumer goods 178, 179  
 Contact process 181–2  
 copolymers 415  
 copper  
   electrorefining 96, 110, 355  
   refining 95–6  
 copper chloride, dissolving 565  
 corrosion 68–9, 339  
   dry 69  
   observing 71  
   prevention 72, 73  
   rate of 72–3  
   wet 69–70  
 corrosion process 69–70  
 covalent bonding 233–42  
   alkanes 247  
   molecules and molecular  
   substances 235–6  
 covalent bonds, forming 233–4  
 covalent layer lattice 242  
 covalent network lattice 241–2  
 covalent substances, intermolecular  
   forces 237  
 cracking 184, 419  
   catalytic 185  
   thermal 184  
 crop competition  
   competitors 198–9  
   pyrethroids 198  
 cross-linked polymers 410–11  
 cross-links 410  
 crude oil 419–20  
   fractionation 124–5  
   fractions 124–5  
 cycloalkanes 252, 253  
 cyclohexene 252  
 Dalton, John 5–6  
 Dalton's Law of Partial Pressure 307  
 DDT  
   (dichlorodiphenyltrichloroethane)  
   197–8  
 de Broglie, Louis 9  
 Dead Sea water 107  
 decomposition reactions 329  
 deliquescent substances 464  
 delocalised electrons 244  
 Democritus 3  
 denitrification 548  
 density 448–9  
 desiccants 464  
 desorption 444, 501  
 detergents 85, 90–1  
   synthetic 89–90  
 diamond 241–2  
 diatomic molecules 235, 236  
 diffusion 306–7  
 digestion 534–5  
 dilute acids or bases 373  
 dilutions 297–8  
 dimethyl sulfide 204, 549  
 dipeptides 405, 536  
 dipole–dipole attractions 238, 239  
 dipoles 238, 239, 240, 400  
 diprotic acids 370, 374  
 disaccharides 412, 538, 539, 540  
 dispersion forces 238, 239, 252, 411  
 dissociation 470, 554  
 dissolved oxygen, in water 61  
 dissolving 286–7, 554  
   forces of 287–8  
 DNA 235, 412  
 DNA analysis 173–4  
 DNA fingerprinting 504  
 double beam scanning  
   spectrophotometer 495  
 double covalent bond 234  
 double replacement reactions 330,  
   331, 333  
 drawing organic compounds 390  
 driving forces of a reaction 557–8



- drug development 164  
 aspirin 165–6  
 thalidomide 165–6  
 dry corrosion 69  
 ductility 244, 246  
 dust explosion 516–17  
 dynamic equilibrium 555
- Earth, energy distribution 202–4  
 Earth's atmosphere 20–1  
 functions of 42  
 gases 42, 45–8  
 human impact on 22–3  
 layers of 43–5  
 ease of oxidation 348–9  
 Einstein, Albert 8  
 energy–mass equation 13  
 electrical conductivity 244–5  
 electrochemical cells 348–52  
 emf and chemical reactions 354–5  
 making 350–1  
 electrochemical series 352–4, 368  
 electrodes 349  
 electrolysis 355  
 Faraday's laws 358–61  
 molten sodium chloride 104–5  
 predicting products of 356–7  
 zinc 99  
 electrolytic cells 111, 113, 355  
 electromagnetic spectrum 494  
 electron configurations 216–17, 222  
 noble gases 228, 229  
 electron dot formula 235  
 electron orbitals 218, 219, 229  
 electron shells 215–20  
 electron subshells 218, 219  
 electron transfer 341  
 electronegativities 237, 238  
 electronic structure 215–17  
 electrons 209, 210, 211  
 electrophoresis 504  
 electroplating 111–12, 115  
 electrorefining 96, 110  
 electrowinning 99, 110–11  
 elementary reactions 523  
 elements 5, 211–12  
 electron configurations 216–17  
 electronegativities 237  
 formation of 11, 12–13, 14, 15  
 isotopes 212  
 names and symbols 6, 212–13  
 organisation 6–7  
 properties 226–8  
 relative isotopic mass 214  
 emission spectra 8, 488, 489  
 empirical formula 460–1, 462  
 determination 462–3  
 hydrated salts 464–5  
 end point 467  
 endothermic reactions 185, 425–6,  
 434, 557, 558  
 energy profile 426  
 energy profile diagrams 514  
 energy  
 definition 423  
 from food 133–40  
 energy distribution on Earth 202  
 comparison with Mars 202  
 ocean currents 202–3  
 water as temperature regulator  
 203–4  
 water vapour 203  
 energy intake, balancing 140–1  
 energy levels (electrons) 215, 442  
 energy profile diagrams 514  
 endothermic reactions 514  
 enzyme-catalysed reactions 519  
 exothermic reactions 514  
 energy profiles  
 endothermic reactions 426  
 exothermic reactions 424, 425  
 energy sources 122–31  
 energy use, in activities 141  
 enthalpy 424, 433–4, 435  
 entropy 434, 435  
 enzyme-catalysed reactions 519, 524  
 enzymes 519, 533, 535, 540  
 denaturation 533  
 pH effects 533, 541, 542  
 temperature effects 533, 540–1  
 equilibrium 555  
 adding a solid or liquid reactant  
 to system at 564–5  
 changing pressure of a gas system  
 562–3  
 concentration change 559–61  
 Le Chatelier's Principle 559–65  
 position of 556  
 and reaction rate 558  
 temperature change 561–2  
 equilibrium constant ( $K_a$ ) (weak acids)  
 569, 570  
 equilibrium constant ( $K_b$ ) (weak  
 bases) 569, 570  
 equilibrium constant ( $K_{eq}$ )  
 approximations to simplify  
 calculations 569–70  
 calculating 567  
 calculating an unknown  
 concentration 567–8  
 definition 566–7  
 more complex calculations 568–9  
 equilibrium constant ( $K_w$ ) (self-  
 ionisation of water) 577  
 equilibrium law expression 566, 567  
 equivalence point 467, 469  
 essential nutrients 189  
 ester hydrolysis 37  
 ester linkages 544  
 esterification 36–7, 402  
 esters 35–6, 186, 388, 402  
 general formula 36  
 synthesis 36–7, 401, 402, 416–17  
 systematic naming 38
- ethane 247  
 ethanoic acid 38, 53, 147, 186, 254–5,  
 374  
 structural formula 401  
 in vinegar 157  
 ethanol 37, 146, 254  
 content of alcoholic beverages  
 149–50, 395  
 from ethene 186, 393  
 from fermentation 396  
 as fuel 124, 125–6, 133  
 solvent properties 397–8  
 ethene  
 addition polymerisation 414  
 covalent bonding 247  
 halogenation 393  
 hydrogenation 393  
 properties 185  
 structural formula 248  
 uses 186–7  
 ethene manufacture 184–5  
 ether linkage 540  
 ethers 388  
 ethyl ethanoate 186  
 excess reagents, stoichiometric  
 calculations 277–8  
 excited state (electrons) 441  
 exothermic reactions 122, 123, 130,  
 424–5, 434, 557  
 energy profile 424, 425, 426  
 energy profile diagrams 515
- Faraday's laws of electrolysis 358  
 Faraday's First Law 358–9  
 Faraday's Second Law 360–1  
 fats 191  
 in the diet 544  
 energy content 140  
 monounsaturated 544  
 polyunsaturated 544  
 reaction with hydroxides 402  
 saturated 544  
 fatty acids 543  
 oxidation 544  
 in triglyceride synthesis 544–5  
 felt-tip pens, chromatography 445–6  
 fermentation 145–6, 396  
 fertilisers 156, 182, 195–6  
 first-order reactions 526, 527  
 flame tests 172, 441–3, 488  
 flavours 35–6  
 foam column 521  
 food  
 composition 140  
 energy content 133–40  
 as fuel 133–4  
 nutrients 189–92  
 food analysis  
 iron content 161, 492–3  
 testing for ions 117–18  
 testing for other substances 120  
 testing for salt 118–20



- food components, forensic identification 172  
 food production 193–6  
 forensic chemistry 170–1, 174  
   DNA analysis 173–4  
 forensic testing  
   identification of metals 172  
   identifying food components 172  
   pigment analysis 172–3  
 formaldehyde 238  
 fossil fuels 124–5, 419–20  
   burning of 123  
 fractional distillation 184  
 froth flotation 98  
 fructose 539, 540  
 fuel alternatives 125–6, 133  
 fuel cells 130–1  
 fuels 123  
   comparing 127–8  
   energy from combustion 124  
   heat of combustion 127  
 functional groups 254, 386–8  
   properties 400  
 fungicides 197  
 fusion reactions 13–15
- galactose 539  
 gas laws 310  
   Boyle's Law 311–13  
   Charles' Law 314, 315  
   combined gas equation 317–18  
   General Gas Equation 319–20  
   pressure–temperature relationship 316  
   volume–number of moles relationship 316–17  
 gas–liquid chromatography (GLC) 503–4  
 gas pressure 307  
   measurement 308–9  
 gases  
   atmospheric 42, 45–8  
   early studies on 5  
   kinetic molecular theory 306–7  
   measuring pressure and volume 308–9  
   molar volume 321–3  
   physical properties 305–6  
   solubility 293–4  
   stoichiometric calculations 323–4  
 General Gas Equation 319–20  
 global warming 23  
 glucose 133, 134, 189, 412, 539  
   condensation reactions 540  
   fermentation 145–6  
   heat of combustion 137–9  
   structure 543  
 glycerol 543, 544  
 glycogen 539, 543  
 gold, in sea water 105  
 graphite 242
- gravimetric analysis 156, 456–9  
   percent composition of compounds and mixtures 458–9  
   precipitation reactions 456–7  
 greenhouse effect 23, 123  
 groups (periodic table) 7, 220, 222, 227  
   trends down 258
- Haber process 196–7, 562  
 half cell equations 353  
 half cells 352  
 half equations 341, 352  
   to balance redox equations 346–7  
 haloalkanes 387  
 halogenation 393  
 halogens 228  
 hard water 87  
 heat  
   definition 424  
   and temperature 424  
 heat of combustion 430  
   carbohydrate, fat and protein 140  
   fuels 127  
   glucose 137–9  
   vegetable oil 136  
 heat of reaction, measuring 430–2  
 heat treatment, metals 32–3  
 helium atom 12, 13  
 herbicides 197  
 heterogeneous catalysts 519  
 hexane  
   combustion 125  
   isomers 251  
 3-hexanol 38  
 high-density polyethene (HDPE) 414  
 high performance liquid chromatography (HPLC) 502–3  
 history of chemistry 2–9  
 homogeneous catalysts 517  
 homogeneous mixture 287  
 homologous series 387–8  
   alkanes 247  
   alkenes 248  
 hydrated ions 288  
 hydrated salts 464–5  
 hydration 554  
 hydrocarbons 246–8, 386–93  
   intermolecular forces 252, 400  
   investigations 249  
   reactivity 394  
   ring molecules 252–4  
   saturated 248, 250–1  
   unsaturated 248, 250  
 hydrochloric acid 370, 371, 373, 374, 470  
   in brick cleaner 156  
   reactions 369  
 hydrogen  
   as fuel 124  
   molar volume 322–3  
 hydrogen atom 12, 13, 211
- hydrogen bonding 238, 239, 287, 400  
 hydrogen carbonate ion 55  
 hydrogen chloride molecule 234  
   polarised bond 238  
   representations 236  
 hydrogen half cell 352  
 hydrogen molecule 233  
 hydrogen–oxygen fuel cell 131  
 hydrogen sulfide 549  
 hydrolases 535, 537, 539, 543  
 hydrolysis 535  
 hydronium ion 379, 577, 578  
 hydrophilic part (molecules) 85, 89  
 hydrophobic part (molecules) 85, 89  
 hydroxide ion 577, 578  
 hydroxides  
   reaction with carboxylic acids 401  
   reaction with fats 402  
 hydroxyl functional group 254, 387  
 hygroscopic substances 464  
 hyperbaric chamber 25, 49
- ideal gas constant 319  
 ideal gas equation 319–20  
 indicators 379, 380–2, 468–9  
   choice of in acid–base titrations 469–70  
   pH range 469  
 infrared spectrometer 497  
 infrared spectroscopy 168, 496–8  
 infrared spectrum 497–8  
 inhibitors 519  
 insecticides 197–8  
 insoluble substances 288  
 intermediates 523  
 intermolecular forces 237–8  
   hydrocarbons 252, 400  
   types of 239  
 interstitial alloys 29–30  
 ionic bonding 229–32, 257  
 ionic compounds 229, 230–1, 237  
   ionisation 288  
   properties 231–2, 257  
   solubility 289, 331  
   writing chemical formulae of 231  
 ionic equations 333  
 ionic lattices 231  
 ions 229  
   acid–base properties 380  
   names and formulae 230  
   testing for (in food) 118  
 iron in food, colorimetric analysis 161, 492–3  
 isotopes 212  
   relative isotopic mass 213–14
- kelvin scale 314–15  
 ketones 387, 398  
   properties 400  
 Kevlar 81  
 kinetic molecular theory 306–7



- lactose 539  
 lanthanides 227  
 latent heat 426–7  
 lattices  
   covalent 241–2  
   ionic 231  
 Lavoisier, Antoine 5, 6  
 Law of Conservation of Energy 423  
 Law of Conservation of Mass 273  
 Law of Multiple Proportions 6  
 Le Chatelier's Principle 185, 559  
   adding a solid or liquid reactant to system at equilibrium 564–5  
   changing pressure of a gas system 562–3  
   concentration change 559–61  
   temperature change 561–2  
 lead–acid batteries 129  
 limestone decomposition 558  
 limiting reagents, stoichiometric calculations 277–8  
 linear shape (molecules) 236  
 lipids 191, 543–5  
   metabolism 544  
   *see also* fats  
 lithium atom 211  
 lithium cells 129  
 local water, quality 58–9  
 localised electrons 242  
 lone pairs 234  
 low-density polyethylene (LDPE) 414  
  
 magnesium chloride 231  
 magnesium ions 231  
 magnesium oxide 231  
 main group elements 227  
 malic acid 146, 147, 150  
 malleability 244, 246  
 malolactic fermentation 150  
 maltose 539, 540  
 manometers 308–9  
 Mars  
   atmosphere 25  
   energy from the Sun 202  
   terraforming 26  
 marshmallows, energy from 135  
 mass number 212  
 mass of solute per mass of solution (w/v) 54, 155  
 mass of solute per volume of solution (mg/g) 54, 155  
 mass spectrometry 168  
 matter cycles 546–9  
 melting points 449–50  
 Mendeleev, Dmitri 7  
 mesopause 44  
 mesosphere 44  
 metabolism 535  
 metal carbonates, and acids 368  
 metal crystals, growing 245  
 metal hydroxides, and acids 369  
  
 metal hydrogen carbonates, and acids 369  
 metal oxides, and acids 369  
 metal sulfides, and acids 369  
 metallic bonding 244–5, 257  
 metallic structure, altering 31–2  
 metalloids 227  
 metals  
   alloys 28–31  
   anodising 113–14  
   electrical conductivity 244–5  
   electroplating 111–12  
   extraction 94–100  
   flame tests 442  
   forensic identification 172  
   heat treatment 32–3  
   malleability and ductility 244, 246  
   modifying properties 33  
   periodic table 227  
   properties 246, 257  
   purifying 96, 99, 110–11  
   reaction with acids 368, 401  
   work hardening 32  
 methane 247  
   combustion 124, 424–5  
   covalent bonds 235  
 methyl butanoate 38, 401  
 methyl methacrylate 415  
 methyl orange 381, 468, 471  
 methyl propane 251  
 methyl red 380  
 Meyer, Julius Lothar 7  
 mineral ores, metal extraction 94–100  
 minerals (nutrients), functions, sources and deficiencies 192  
 mines, in Queensland 93–4  
 mining the sea 104–7  
 mobile phase 444, 502, 503  
 molar heat of a chemical reaction 431–2  
 molar mass 269  
 molar volume 321–2  
   of hydrogen 322–3  
 molarity 296–7  
 molecular formulae 461–2  
 molecular shapes 236  
 molecules and molecular substances 235–6  
   covalent bonding 235–6, 257  
   intermolecular forces 237–9  
   names and formulae 241  
   properties 240–1, 257  
   representations 235, 236  
 mole(s) 268–9  
   calculating number of 270  
   and representative particles 268, 270–1  
 molten sodium chloride, electrolysis 104–5  
 monochromator 490  
 monomers 409, 414, 415, 416, 417, 419  
  
 monoprotic acids 370, 374  
 monosaccharides 412, 538, 539, 540  
 monounsaturated fats 544  
  
 nanotubes 82–3  
 natural medicines 163  
 natural polymers 411–13  
 net ionic equation 333  
 neutralisation reactions 367, 379  
 neutron stars 15  
 neutrons 210, 211  
 Newlands, John 6–7  
 nickel refining 96–7  
 nitrates 548  
 nitric acid 371, 470  
 nitrification 548  
 nitrogen  
   in the atmosphere 46  
   in lawn food 158  
   solubility 205  
 nitrogen cycle 547–8  
 nitrogen dioxide–dinitrogen tetroxide system 558  
   temperature and pressure effects on equilibrium 563–4  
 nitrogen fertilisers 195–6  
 nitrogen fixation 547  
 noble gases 228  
   electron configuration 228, 229  
 Nomex 81  
 non-bonding pairs 234  
 non-essential nutrients 189  
 non-metals, periodic table 227, 230  
 non-spontaneous reactions 433  
 nuclear fusion 13–14  
 nuclear fusion reactors 17  
 nuclear magnetic resonance spectrometer 499–500  
 nuclear magnetic resonance spectroscopy (nmr) 168, 499–501  
 nucleus (atoms) 210  
 nutrients 189–92  
   for plant growth 193–4  
 nylon 417–19  
  
 ocean currents 202–3  
 oceans  
   carbon dioxide absorption 205  
   dimethyl sulfide 204, 549  
 octane 124, 185  
   combustion 133, 557  
 oil resources 419–20  
 OIL RIG 341  
 orbitals (electrons) 218, 219, 220  
 order of reactions 526–7  
   and rate laws 527–8  
 organic acids, reactions 401–2  
 organic compounds 246–55, 386–405  
   drawing 390  
   systematic naming 388–9  
 organic reactions 391–4



- origin (paper chromatography) 444  
 overall ionic equation 333  
 oxidants 341  
 oxidation 339, 341  
   of alcohols 398–400  
   ease of 348–9  
 oxidation numbers  
   assigning 343–4  
   to balance redox equations 345–6  
   using 344–5  
 oxidation–reduction reactions  
   see redox reactions  
 oxygen 25  
   in the atmosphere 47  
   solubility 205  
 oxygen cycling 547  
 oxygen molecule 234  
   representations 236  
 ozone 44, 46  
 ozone layer 44
- paper chromatography 444–5, 502  
   felt-tip pens and Smarties 445–6  
   vegetable extract 446–7  
 partial electron transfer 342  
 partial pressure 307  
 peptide bonds 405, 536  
 peptide chain 537  
 percent by mass (w/w) 54, 155  
 percent by volume (v/v) 54, 155  
 percent composition of compounds  
   and mixtures 458–9  
 percent yield 280–1  
 periodic table 7, 220–2  
   and properties 228  
   trends within 257–9  
 periods 7, 220  
   trends across 258–9  
 pesticides 197–8  
 pH 578  
   effect on enzymes 533  
   measurement 378  
   wine 147  
 pH scale 376–8, 578  
 pharmaceuticals  
   analysis 167–8  
   development 164–6  
   early 162–3  
   from natural sources 163  
 phenolphthalein 380, 381, 469, 471, 472  
 phenyl group 253  
 phosphate in laundry powder 160–1  
 phosphoric acid 370, 374  
 phosphorus cycle 548–9  
 photosynthesis 532–3, 557  
 physical properties 226  
   and periodic table 227–8  
   used in qualitative analysis 448–50  
 pigment analysis 172–3  
 Planck, Max 8
- plant growth  
   adding nutrients through fertilisers 195–6  
   nutrients for 193–4  
   soil structure effects 194–5  
 plant pigments, chromatography 446–7  
 plum-pudding model (atom) 7  
 point of inflexion 473  
 polar bonds 238  
   ionisation 287–8  
   within water molecules 240  
 polar covalent molecules 400  
   hydrogen bonding to water molecules 287  
 polar molecules 238  
 polyacrylonitrile 414  
 polyamide 417  
 polyesters 417  
 polyethene 185, 186, 247, 410, 411, 414  
 polymerisation  
   addition 414–15  
   condensation 416–18  
 polymers 75, 409  
   cross-linked 410–11  
   historic development 76  
   identifying 77  
   natural 411–13  
   properties 411  
   recycling 77, 420  
   reusing 420  
   structure 79  
   synthetic fibres and composites 80–1  
   testing 78–9  
   thermoplastic 79, 409–10  
   thermosetting 410  
 polymethyl methacrylate 415  
 polypeptides 405, 536  
 polypropene 414, 415  
 polyprotic acids 370  
 polysaccharides 412, 538, 539–40  
 polystyrene 411, 414–15  
 polyunsaturated fats 544  
 polyvinyl chloride (PVC) 411, 414  
 position of equilibrium 556  
 precipitates  
   formed for gravimetric analysis 456–7  
   will they form? 573–5  
 precipitation reactions 117–18, 331–2, 333–4, 456–7  
   to identify unknowns 334–5  
 pressure 307  
   measurement 308–9  
   units of 309–10  
 pressure–temperature relationship (gases) 316  
 Priestley, Joseph 5, 6  
 primary alcohols 395, 398  
 primary standard 467  
 products 272
- propane 247  
   combustion 123  
 propanoic acid 38, 255  
 1-propanol 37  
 2-propanol 37  
 propene 248, 415  
 proteins 190–1, 405, 412, 535–8  
   energy content 140  
   functions 190, 537  
   structure 538  
 proton acceptors 371  
 proton donors 371  
 proton–proton chain 12  
 protons 210, 211  
 pulsars 16  
 pyramidal shape (molecules) 236
- qualitative analysis 440  
   chromatography 443–7  
   dissolved oxygen and BOD in water 61–2  
   drugs 167  
   flame tests 441–3  
   using chemical properties 450–1  
   using physical properties 448–50  
   water at collection site 60  
 quality control 153–5  
   techniques 154  
 quanta of energy 8  
 quantitative analysis 440, 451–2  
   chloride ions in water 65  
   water hardness 63  
   wine 146–8  
 quantum mechanics 8, 9, 218, 219  
 quenching 32
- rate-determining step 524  
 rate laws 527–8  
 rates of reaction 514–15  
   antacid tablets 522  
   catalyst effects 516–19, 521  
   collision theory 514–15  
   concentration effects 515–16, 526–7  
   and equilibrium 558  
   measuring 520–1  
   surface area effects 516–17  
   temperature effects 515  
 reactants 272  
 reaction mechanisms 523–5  
 rechargeable cells 129  
 recycling 77, 420  
 redox equations  
   balancing using half equations 346–7  
   balancing using oxidation numbers 345–6  
 redox reactions 133, 338–40  
   electron transfer 341  
   partial electron transfer 342  
 redox titrations 478–9  
 reductants 341



- reduction 339, 341  
 relative atomic masses 214, 584  
 relative isotopic masses 213–14  
 representative particles 268  
   calculating number of 270–1  
 respiration 532–3, 540, 544  
 reusing 420  
 reversible reactions 554–8  
   driving forces of a reaction 557–8  
   position of equilibrium 556  
   reaction rate and equilibrium 558  
 $R_f$  value 444–5  
 ring molecules 252–4  
 Rutherford, Ernest, model of the atom 7–8
- saccharides 189, 412, 538–40  
 saccharine 120  
 salicylic acid 164, 165  
 salt  
   from sea water 104  
   testing for in food 118–20  
 salt solutions, acidity 379  
 salts 379–80  
 saponification 86, 88, 402  
 saturated fats 545  
 saturated hydrocarbons 248  
   naming 250–1  
 saturated solutions 290, 554  
 Schrödinger, Erwin 9  
 scuba diving 25, 49  
 sea water  
   bromine in 105–7, 108  
   calcium carbonate in 206  
   carbon dioxide in 205  
   in the Dead Sea 107–8  
   dissolved ions in 102–3  
   gold in 105  
   sodium chloride from 104  
 second-order reactions 527  
 secondary alcohols 395, 398  
 self-ionisation of water 577  
 shell model (atom) 8  
 shells (electrons) 215–20  
 single covalent bond 233  
 single replacement reactions 329–30  
 skin structure 85  
 slime 413  
 Smarties, chromatography 446  
 soap making 86–7, 402  
 soaps 85, 87, 89, 90–1  
   structure 90  
 soda water, effervescence 158  
 sodium azide, decomposition 513  
 sodium chloride  
   dissolving in water 555  
   from sea water 104  
   testing for in food 118–20  
 sodium hydroxide 231, 375  
 sodium ions 231  
 sodium stearate 87
- soil structure 194–5  
 solar system model (atom) 7  
 solder 31  
 solids, solubility 290–1  
 solubility 288–9  
   calculating 572–3  
   compounds in water 289  
   gases 293–4  
   ionic compounds 289, 331  
   solids 290–1  
 solubility curves 290–1, 293  
   deriving 291–2  
 solubility product ( $K_{sp}$ ) 206, 571–2  
   calculating solubility 572–3  
   common ion effect 575–6  
   and precipitate formation 573–5  
 soluble substances 288  
 solute 286, 287  
 solution 286, 287  
 solvent 286, 287  
 specific heat capacity 202, 203, 429–30  
 spectator ions 333  
 spider silk 412–13  
 spontaneous reactions 433  
   enthalpy change 433–4, 435  
   entropy change 434, 435  
   predicting spontaneity 434–5  
 spring water, chemical analysis 52–3  
 stable octet 233  
 stainless steel 30  
 standard reduction potentials 352–4  
 standard solution 467  
   preparation 467–8  
 starch 412, 539  
 starlight, origin of 13–14  
 stars  
   early life of 12–13  
   formation of elements 11, 12–13, 14, 15  
   older 15–16  
 stationary phase 444, 502, 503  
 steady state system 555  
 stoichiometric calculations 275–6  
   involving gases 323–4  
   limiting and excess reagents 277–8  
   summary 277  
 stoichiometry 275–9  
 stomach relief 54–5  
 stratosphere 44  
 strength of acids 373–4  
 strength of bases 375  
 strong acid vs strong base 470  
   titration curve 470–1  
 strong acid vs weak base 471  
   titration curve 471  
 strong acids 373, 374–5, 470  
 strong base vs weak acid 471  
   titration curves 472  
 strong bases 375, 470
- structural formulae 235  
   alkanes 238  
   alkenes 248  
 structural isomers 251  
 styrene 415  
 sublimation 242  
 subshells (electrons) 218, 219  
 substituted benzenes 253–4  
 substitution reactions 392–3  
 substitutional alloys 29  
 substrate 519, 533  
 sucrose 539, 540  
 sulfate content in fertilisers 156  
 sulfur compounds, release into the atmosphere 204  
 sulfur cycle 549  
   on Venus 24  
 sulfur dioxide  
   in the atmosphere 204, 549  
   in wine 147–8  
 sulfur oxides 22  
 sulfuric acid 370, 374  
   industrial uses 182  
   properties 183  
 sulfuric acid manufacture 181–2  
   sulfur to sulfur dioxide 181  
   sulfur dioxide to sulfur trioxide 182  
   sulfur trioxide to sulfuric acid 182  
 Sun's energy, affect on Earth 202–4  
 supernovas 16  
 supersaturated solutions 292–3  
 surface area, affect on rate of reaction 516–17  
 surfactants 85–6  
 sweat glands 85  
 synthetic detergents 89–90  
   structure 90  
 synthetic fibres 80–1  
 systematic naming  
   alcohols 37–8  
   carboxylic acids 38  
   esters 38  
   organic compounds 388–9  
   saturated hydrocarbons 250–1  
   unsaturated hydrocarbons 251
- tannins 145  
 tartaric acid 146, 147, 150  
 Teflon 414, 415  
 temperature  
   effect on enzymes 533, 540–1  
   effect on equilibrium 561–2  
   effect on rate of reaction 515  
   definition 424  
 tempering 32  
 terraforming 26  
 tertiary alcohols 396, 398  
 tetrafluoromethane 238  
 tetrahedral shape (molecules) 236  
 tetramethylsilane (TMS) 500  
 thalidomide 165–6  
 theoretical yield 280



thermal cracking 184  
 thermochemical equations 424, 426  
 thermochemistry 423  
 thermoplastic polymers 409–10  
   structure 79, 410  
 thermosetting polymers 410  
 thermosphere 44–5  
 thin-layer chromatography 502  
 Thomson, J.J, model of the atom 7  
 titration curves (acid–base titrations)  
   469, 473  
   strong acid vs strong base 470–1,  
   473–4  
   strong acid vs weak base 471  
   strong base vs weak acid 472  
   weak acid vs weak base 472–3  
 titration techniques 474–5  
   acid–base titrations 475–6  
   back titrations 476–8  
   redox titrations 478–9  
 titrations 466–7  
   acid–base 468–74  
 total acidity (wine) 146–7  
 total solids in water 64  
 transition metals 227  
 transmittance 497  
 triatomic molecules 236  
 triglycerides 544–5  
 triple alpha reaction 15  
 triple covalent bond 234  
 triprotic acids 370, 374  
 tropopause 43  
 troposphere 43  
 turbidity, water 60

universal gas constant 319  
 universal indicator 381–2  
 universe, beginning of 11  
 unsaturated hydrocarbons 248, 250  
   naming 251–2  
 unsaturated solutions 290  
 UV–visible spectrophotometer 494–5  
 UV–visible spectroscopy 494–6  
 UV–visible spectrum 495–6

V-shaped (molecules) 236  
 valence electrons 217, 222, 229, 244  
 valency 231  
 van der Waal's forces 239  
 vegetable oil, heat of combustion 136  
 Venus's atmosphere 24  
 vibrational energy levels 496  
 vinegar 53  
 visible light, colours of 494  
 vitamins, functions, sources  
   and deficiencies 192  
 voltaic pile 129  
 volume, units of 310  
 volume–number of moles relationship  
   (gases) 316

volume–pressure relationship  
   (gases) 311–12, 313  
 volume–temperature relationship  
   (gases) 314, 315  
 volumetric analysis 156–60, 466–74

water  
   chloride ions, quantitative analysis  
   65  
   dissolved oxygen and BOD,  
   qualitative analysis 61  
   qualitative analysis at collection site  
   60  
   as solvent 565  
   total solids determination 64  
 water content (compounds) 463–4  
 water of crystallisation 463, 465  
 water hardness  
   effect on soap 87  
   quantitative determination 63  
 water molecules 234  
   polar bonding 240  
   representations 236  
 water quality 58  
   local water 58–9  
   testing 59–60  
 water vapour 46, 203  
 waxes 544  
 weak acid vs weak base 472  
   titration curves 472–3  
 weak acids 373, 374–5  
   equilibrium constant ( $K_a$ ) 569, 570  
 weak bases 375  
   equilibrium constant ( $K_b$ ) 569, 570  
 wet corrosion 69–70  
 wine  
   adjustment of elements 150  
   alcohol content 149–50  
   pH 147  
   quantitative analysis 146–8  
   sulfur dioxide content 147–8  
   total acidity 146  
 winemaking process 145  
   ageing 146  
   fermentation 145–6  
 work hardening 32

yeast 145

zinc  
   electrowinning 99, 110–11  
   refining 98–9



# A periodic table of the elements

		Group																			
		1	2	3	4	5	6	7	8	9	10	11	12	13	14	15	16	17	18		
Period	1	1 <b>H</b> 1.00797 Hydrogen																	2 <b>He</b> 4.0026 Helium		
	2	3 <b>Li</b> 6.939 Lithium	4 <b>Be</b> 9.0122 Beryllium											5 <b>B</b> 10.811 Boron	6 <b>C</b> 12.01115 Carbon	7 <b>N</b> 14.0067 Nitrogen	8 <b>O</b> 15.9994 Oxygen	9 <b>F</b> 18.9984 Fluorine	10 <b>Ne</b> 20.183 Neon		
	3	11 <b>Na</b> 22.9898 Sodium	12 <b>Mg</b> 24.312 Magnesium											13 <b>Al</b> 26.9815 Aluminium	14 <b>Si</b> 28.086 Silicon	15 <b>P</b> 30.9738 Phosphorus	16 <b>S</b> 32.064 Sulfur	17 <b>Cl</b> 35.453 Chlorine	18 <b>Ar</b> 39.948 Argon		
	4	19 <b>K</b> 39.102 Potassium	20 <b>Ca</b> 40.08 Calcium	Transition elements																	
	5	37 <b>Rb</b> 85.47 Rubidium	38 <b>Sr</b> 87.62 Strontium	21 <b>Sc</b> 44.956 Scandium	22 <b>Ti</b> 47.90 Titanium	23 <b>V</b> 50.942 Vanadium	24 <b>Cr</b> 51.996 Chromium	25 <b>Mn</b> 54.938 Manganese	26 <b>Fe</b> 55.847 Iron	27 <b>Co</b> 58.933 Cobalt	28 <b>Ni</b> 58.71 Nickel	29 <b>Cu</b> 63.54 Copper	30 <b>Zn</b> 65.37 Zinc	31 <b>Ga</b> 69.72 Gallium	32 <b>Ge</b> 72.59 Germanium	33 <b>As</b> 74.922 Arsenic	34 <b>Se</b> 78.96 Selenium	35 <b>Br</b> 79.909 Bromine	36 <b>Kr</b> 83.80 Krypton		
	6	55 <b>Cs</b> 132.905 Caesium	56 <b>Ba</b> 137.34 Barium	39 <b>Y</b> 88.905 Yttrium	40 <b>Zr</b> 91.22 Zirconium	41 <b>Nb</b> 92.906 Niobium	42 <b>Mo</b> 95.94 Molybdenum	43 <b>Tc</b> [98] Technetium	44 <b>Ru</b> 101.07 Ruthenium	45 <b>Rh</b> 102.905 Rhodium	46 <b>Pd</b> 106.4 Palladium	47 <b>Ag</b> 107.870 Silver	48 <b>Cd</b> 112.40 Cadmium	49 <b>In</b> 114.82 Indium	50 <b>Sn</b> 118.69 Tin	51 <b>Sb</b> 121.75 Antimony	52 <b>Te</b> 127.60 Tellurium	53 <b>I</b> 126.904 Iodine	54 <b>Xe</b> 131.30 Xenon		
	7	87 <b>Fr</b> (223) Francium	88 <b>Ra</b> (226) Radium	57-71 Lanthanoids	72 <b>Hf</b> 178.49 Hafnium	73 <b>Ta</b> 180.948 Tantalum	74 <b>W</b> 183.85 Tungsten	75 <b>Re</b> 186.2 Rhenium	76 <b>Os</b> 190.2 Osmium	77 <b>Ir</b> 192.2 Iridium	78 <b>Pt</b> 195.09 Platinum	79 <b>Au</b> 196.967 Gold	80 <b>Hg</b> 200.59 Mercury	81 <b>Tl</b> 204.37 Thallium	82 <b>Pb</b> 207.19 Lead	83 <b>Bi</b> 208.980 Bismuth	84 <b>Po</b> (210) Polonium	85 <b>At</b> (210) Astatine	86 <b>Rn</b> (222) Radon		
			89-103 Actinoids	104 <b>Rf</b> (261) Rutherfordium	105 <b>Db</b> (262) Dubnium	106 <b>Sg</b> (263) Seaborgium	107 <b>Bh</b> (262) Bohrium	108 <b>Hs</b> (265) Hassium	109 <b>Mt</b> (266) Meitnerium	110 <b>Ds</b> (271) Darmstadtium	111 <b>Rg</b> (272) Roentgenium	112 <b>Uub</b> (277) Ununbium	113 <b>Uut</b> (284) Ununtrium	114 <b>Uuq</b> (289) Ununquadium	115 <b>Uup</b> (288) Ununpentium	116 <b>Uuh</b> (289) Ununhexium					
				57 <b>La</b> 138.91 Lanthanum	58 <b>Ce</b> 140.12 Cerium	59 <b>Pr</b> 140.907 Praseodymium	60 <b>Nd</b> 144.24 Neodymium	61 <b>Pm</b> [147] Promethium	62 <b>Sm</b> 150.35 Samarium	63 <b>Eu</b> 151.96 Europium	64 <b>Gd</b> 157.25 Gadolinium	65 <b>Tb</b> 158.924 Terbium	66 <b>Dy</b> 162.50 Dysprosium	67 <b>Ho</b> 164.930 Holmium	68 <b>Er</b> 167.26 Erbium	69 <b>Tm</b> 168.934 Thulium	70 <b>Yb</b> 173.04 Ytterbium	71 <b>Lu</b> 174.97 Lutetium			
				89 <b>Ac</b> (227) Actinium	90 <b>Th</b> 232.038 Thorium	91 <b>Pa</b> (231) Protactinium	92 <b>U</b> 238.03 Uranium	93 <b>Np</b> (237) Neptunium	94 <b>Pu</b> (242) Plutonium	95 <b>Am</b> (243) Americium	96 <b>Cm</b> (247) Curium	97 <b>Bk</b> (247) Berkelium	98 <b>Cf</b> (249) Californium	99 <b>Es</b> (254) Einsteinium	100 <b>Fm</b> (253) Fermium	101 <b>Md</b> (256) Mendelevium	102 <b>No</b> (254) Nobelium	103 <b>Lr</b> (257) Lawrencium			